

Model: PF55451-1 (470)
15 gal (56.8 l) Fluid Dispenser

06/2026 – Rev. 01

For Spare Parts, Operations & Service Manuals or Service Needs
Scan the QR code or visit tronair.com/pages/tronair-information-center



The Tronair Group of Companies: Tronair | Columbus Jack | Eagle | Malabar International

Malabar International

1 Air Cargo Pkwy East
Swanton, OH 43558

Phone: (419) 866-6301 | 800-426-6301

Web: www.tronair.com
Email: sales@tronair.com

REVISION
01

DATE
06/2026

TEXT AFFECTED
Original release

TABLE OF CONTENTS

PAGE

1.0	PRODUCT INFORMATION	1
1.1	DESCRIPTION.....	1
1.2	MODEL & SERIAL NUMBER.....	1
1.3	MANUFACTURER.....	1
1.4	SPECIFICATIONS	1
2.0	SAFETY INFORMATION.....	1
2.1	USAGE AND SAFETY INFORMATION	1
3.0	PREPARATION PRIOR TO FIRST USE	1
4.0	TRAINING.....	1
4.1	TRAINING REQUIREMENTS	1
4.2	TRAINING PROGRAM	1
4.3	OPERATOR TRAINING	1
5.0	OPERATION.....	2
6.0	TROUBLE SHOOTING	2
7.0	MAINTENANCE.....	2
7.1	SERVICING	2
7.2	REPAIR AND REPLACEMENT	2
7.3	OVERHAUL INSTRUCTIONS.....	2
7.3.1	Hand Pump Disassembly (see figure 2).....	2
7.3.2	Hand Pump Reassembly (see figure 2)	3
7.3.3	Relief Valve Setting (see figure 2).....	3
8.0	PROVISION OF SPARES.....	3
8.1	SOURCE OF SPARE PARTS.....	3
8.2	RECOMMENDED SPARE PARTS LISTS	3
9.0	IN SERVICE SUPPORT.....	3
10.0	GUARANTEES/LIMITATION OF LIABILITY	4

This product can not be modified without the written approval of Tronair, Inc. Any modifications done without written approval voids all warranties and releases Tronair, Inc., its suppliers, distributors, employees, or financial institutions from any liability from consequences that may occur. Only Tronair OEM replacement parts shall be used.



CAUTION!

Aircraft manufacturer's specifications and instructions must be followed. In the event of contradiction between aircraft manufacturer's specifications and Malabar's, aircraft manufacturer's will prevail.

1.0 PRODUCT INFORMATION

1.1 DESCRIPTION

The Malabar Model PF55451-1 is a 15 gallon fluid dispenser used to service various commercial aircraft. The hand pump dispenser consists of a reservoir, pump assembly with relief valve, filter assembly, and a fluid delivery hose.

1.2 MODEL & SERIAL NUMBER

Reference nameplate on unit

1.3 MANUFACTURER

TRONAIR, Inc., Malabar International Telephone: (419) 866-6301 or 800-426-6301
1 Air Cargo Pkwy East Fax: (419) 867-0634
Swanton, Ohio 43558 USA E-mail: sales@tronair.com
Website: www.tronair.com

1.4 SPECIFICATIONS

FluidPetroleum Based
Reservoir capacity..... 15 gal (56.8 l)
Relief valve set at..... 150 ± 10 psig (1034 ± 69 kPa)
Volume per stroke4 cubic in (65.5 cc)
Hose length 120 in (3048 mm)
Net weight (empty)82 lbs (37.2 kg)
Filter rating3 micron nominal

2.0 SAFETY INFORMATION

2.1 USAGE AND SAFETY INFORMATION

To ensure safe operations please read the following statements and understand their meaning. Also refer to your equipment manufacturer's manual for other important safety information. This manual contains safety precautions which are explained below. Please read carefully.



WARNING!

Warning is used to indicate the presence of a hazard that can cause **severe personal injury, death, and/or substantial property damage** if the Warning Notice is ignored.



CAUTION!

Caution is used to indicate the presence of a hazard, which will or can cause **minor personal injury or property damage** if the Caution Notice is ignored.

3.0 PREPARATION PRIOR TO FIRST USE

The unit is shipped fully assembled. Fill reservoir at fillport with approved fluid. Operate hand pump assembly a few strokes to bleed all air out of the system. The unit is now ready for use.

4.0 TRAINING

4.1 TRAINING REQUIREMENTS

The employer of the operator is responsible for providing a training program sufficient for the safe operation of the unit.

4.2 TRAINING PROGRAM

The employer provided operator training program should cover safety procedures concerning use of the unit in and around the intended aircraft at the intended aircraft servicing location.

4.3 OPERATOR TRAINING

The operator training should provide the required training for safe operation of the unit.

NOTE: Maintenance and Trouble Shooting are to be performed by a skilled and trained technician.

5.0 OPERATION

1. Connect the hose to the aircraft service point.
2. Use full steady pumping strokes when operating pump assembly during replenishing.
3. Disconnect the hose from the aircraft service point, replace dust plug kit and store the unit in a dry, dust free location.

6.0 TROUBLE SHOOTING

If pump assembly loses prime, pressure or volume output:

1. Check fluid level.
2. Dirt or foreign particles may be lodged in valve body or adapter assembly. Clean with solvent and dry with compressed air. Replace o-rings before reassembling.
3. Check condition of filter element. Replace as required.
4. Oil screen may be clogged. Clean with solvent and dry with compressed air.
5. Relief valve may need to be reset. Adjust relief valve per overhaul instructions.
6. Piston o-ring may be worn. Replace per overhaul instructions.
7. Hydraulic hose, fittings or tubing may be leaking. Tighten or replace as required.

7.0 MAINTENANCE**7.1 SERVICING**

1. The frequency of filter change depends on operating conditions. Generally, changes should be made every 3-4 months or sooner if more than normal resistance is felt on the pumping stroke at low pressure. Refer to item 8 in figure 1B to change element.
2. Lubricate wheel bearings as required. Refer to item 12 in figure 1B.

7.2 REPAIR AND REPLACEMENT

No definite time schedule can be established for the overhaul of the pump assembly for the replacement of the various moving parts. The number of times the pump assembly is operated materially affects the life of the working parts. The moving piston seal (item 9) and scraper (item 8) are normally the first to wear. This is usually indicated by leakage of fluid past the plunger (item 2). It is advisable to overhaul the pump assembly immediately if leakage is discovered as described below in overhaul instructions. A repair parts kit (P/N PF15-2PK) is available and recommended to keep on hand at your facility. Refer to repair parts kit for the complete list of parts contained in the repair parts kit.

7.3 OVERHAUL INSTRUCTIONS

During overhaul, replace all parts that do not pass the following inspection requirements. Each time the pump assembly is disassembled, carefully inspect for the following:

1. Inspect interior walls of cylinder and outer walls of plunger and piston for smoothness and freedom from rust, pits, scratches and excessive wear.
2. Check oil screen for cleanliness.
3. Regardless of apparent condition, replace all o-rings, scrapers, retaining rings, gaskets, roll pins, flathead pins, cotter pins, ball valves and filter element.
4. Coat all o-rings and back-up rings with compatible fluid prior to assembly.
5. Clean all metal parts with clean solvent and dry with compressed air. Lubricate all threads.
6. Use Teflon tape carefully on all pipe threads. Remove excess tape because it can clog valves and passages.
7. If ball valves do not seat properly, they may need to be resealed by tapping the ball into the valve seat with a brass rod cupped at one end.

7.3.1 Hand Pump Disassembly (see figure 2)

1. Remove ten bolts and lockwashers (figure 1B, items 3 & 4) from cover (item 7) and lift pump assembly and gasket (figure 1B, items 1 & 2) from tank (figure 1A, item 1).
2. Remove handle (item 16) and pump link (item 17) by removing cotter pins (items 19) and flathead pins (items 18).
3. Remove tubing (item 26).
4. Unscrew nipple (item 20) and attached parts (items 20, 21, 22, 23 and 24) from valve body (item 4). Pull out valve body (item 4), adapter (item 5), nipple (item 13) and oil screen (item 14) from cylinder (item 1). Remove o-ring (item 9) from valve body.
5. Unscrew adapter (item 5), nipple (item 13) and oil screen (item 14) from valve body (item 4). Remove o-ring (item 28) and ball (item 12).
6. Tap out roll pin (item 15) from plunger (item 2) and slip off collar (item 6).
7. Pull plunger (item 2) and piston (item 3) out of cylinder (item 1).
8. Remove retaining ring (item 11) from plunger (item 2) and slide piston (item 3) off. Remove o-ring (item 10) from plunger and o-ring (item 9) from piston.
9. Unscrew cylinder (item 1) from cover (item 7).
10. Remove retaining ring (item 27) and scraper (item 8) from cover (item 7).

7.3.2 Hand Pump Reassembly (see figure 2)

1. Install scraper (item 8) and retaining ring (item 27) onto cover (item 7).
2. Screw cylinder (item 1) onto cover (item 7).
3. Install o-ring (item 10) onto plunger (item 2). Next install o-ring (item 9) onto piston (item 3). Finally install piston onto plunger and secure with retaining ring (item 11).
4. Slide plunger (item 2) and piston (item 3) assembly into cylinder (item 1).
5. Slide collar (item 6) onto plunger (item 2) and install roll pin (item 15) through both.
6. Install o-ring (item 9) onto valve body (item 4). Next install o-ring (item 28) onto adapter (item 5). Place steel ball (item 12) into valve body (item 4). Attach adapter (item 5), nipple (item 13) and oil screen (item 14) to valve body (item 4). Install the entire assembly into the cylinder (item 1) and align thread with hole in cylinder.
7. Attach nipple (item 20) and connected parts (items 20, 21, 22, 23 and 24) to valve body (item 4) and cylinder (item 1).
8. Attach tubing (item 26) to connectors (items 24 & 25).
9. Install handle (item 16), pump link (item 17), flathead pins (items 18) and cotter pins (items 19).
10. Place gasket (figure 1B, item 2) and pump assembly on tank (figure 1A, item 1). Install 10 bolts and 10 lockwashers (figure 1B, items 3 & 4) and secure pump assembly to the tank.

7.3.3 Relief Valve Setting (see figure 2)



CAUTION!

The relief valve should not be adjusted unless absolutely necessary. If adjustment is required, proceed as follows:

1. Remove pump assembly and gasket from tank as described in step 1a.
2. Install tee, pressure gauge (0-200 psig) and shut off valve to the end of the hose assembly (figure 1A, item 7).
3. Bleed air from pump assembly.
4. Remove cap from end of relief valve (item 22) and loosen locknut on relief valve. Using 3/16 wrench, adjust relief valve to 150 ± 10 psig. Replace locknut and cap upon completion.
5. Remove tee, shut off valve and pressure gauge from hose assembly.
6. Attach gasket and pump assembly to tank as described in 6.3.2 step 10.

8.0 PROVISION OF SPARES

8.1 SOURCE OF SPARE PARTS

Spare parts may be obtained from the manufacturer:

TRONAIR, Inc., Malabar International
1 Air Cargo Pkwy East
Swanton, Ohio 43558 USA

Telephone: (419) 866-6301 or 800-426-6301

Fax: (419) 867-0634

E-mail: sales@tronair.com

Website: www.tronair.com



For Spare Parts, Operations & Service Manuals or Service Needs:

Scan the QR code or visit Tronair.com/aftermarket

8.2 RECOMMENDED SPARE PARTS LISTS

Reference the following page(s) for Replacement Parts and Kits available.

Refer to figure 1A, and 1B for unit assembly or figure 2 for pump assembly.

9.0 IN SERVICE SUPPORT

Contact Malabar, Inc. for technical services and information. See Section 1.3 – Manufacturer.

10.0 GUARANTEES/LIMITATION OF LIABILITY

- I. Seller warrants each new product of its manufacture to be free from defects in material or workmanship, under proper, reasonable, and normal use and service.
- II. The warranty period shall be as follows:
 - A. For Malabar equipment, with the exception of Tripod Jacks, the warranty period is one (1) year after date of shipment.
 - B. For Malabar Tripod Jacks, the warranty period is three (3) years after date of shipment.
- III. Where Buyer claims an alleged defect in material or workmanship and so advises Seller in writing within ten (10) days after discovery thereof, then and in such event, Buyer shall return said equipment, transportation prepaid, to the Seller, provided such return is timely and within the above-mentioned warranty period. This warranty and liability of the Seller is expressly limited solely to replacement or repair of defective parts or goods, and return at Buyer's expense to Buyer after finding by Seller the product was defective prior to original shipment or, at the option of Seller, to providing refund to Buyer of the purchase price for said product.
- IV. It is further expressly understood and agreed that:
 - A. THERE IS NO WARRANTY, REPRESENTATION OF CONDITION OF ANY KIND, EXPRESS OR IMPLIED, (INCLUDING NO WARRANTY OF MERCHANTABILITY OR OF FITNESS) EXCEPT THAT THE MATERIAL SHALL BE OF THE QUALITY SPECIFIED IN APPLICABLE SPECIFICATIONS, AND NONE SHALL BE IMPLIED BY LAW. Except as otherwise provided herein, quality shall be in accordance with Seller's specifications. Final determination of the material for the use contemplated by Buyer is the sole responsibility of Buyer and Seller shall have no responsibility in connection with such suitability, and
 - B. Buyer's sole and exclusive remedy shall be repair or replacement of defective parts or goods by the Seller. Should the goods, in the judgment of Seller, preclude the remedying of the warranted defects by repair or replacement, the Buyer's sole and exclusive remedy shall be the refund of the purchase price, and
 - C. Seller shall not be liable for prospective profits or special, indirect or consequential damages, nor shall any recovery of any kind against Seller be greater in amount than the purchase price of the specific material sold and causing the alleged loss, damage or injury. Buyer assumes all risk and liability for loss, damage or injury to persons or property of Buyer or others arising out of use or possession of any product or part sold hereunder, and
 - D. Seller shall in no way be deemed or held to be obligated, liable or accountable upon or for any guarantees or warranties, express or implied, or created by statute or by operation of law or otherwise, in any manner of form beyond its express agreement above set forth, and
 - E. No warranty herein shall apply to any product which shall have been repaired or altered, unless such alteration or repair has been made by Seller or if, after return to and inspection by Seller, the product is found by Seller to have been subject to misuse, negligence or accident, and
 - F. No warranty of any nature is made by Seller as to any component forming a part of the product sold and Buyer shall receive only such warranties offered by such other manufacturer of such component, and
 - G. Seller does not assume nor does Seller authorize any other person to assume for it any other liability or make any warranty in connection with the sale of its products.

Parts List – Figure 1A

When ordering replacement parts/kits, please specify model, serial number and color of your unit.

◆ PART OF REPAIR PARTS KIT

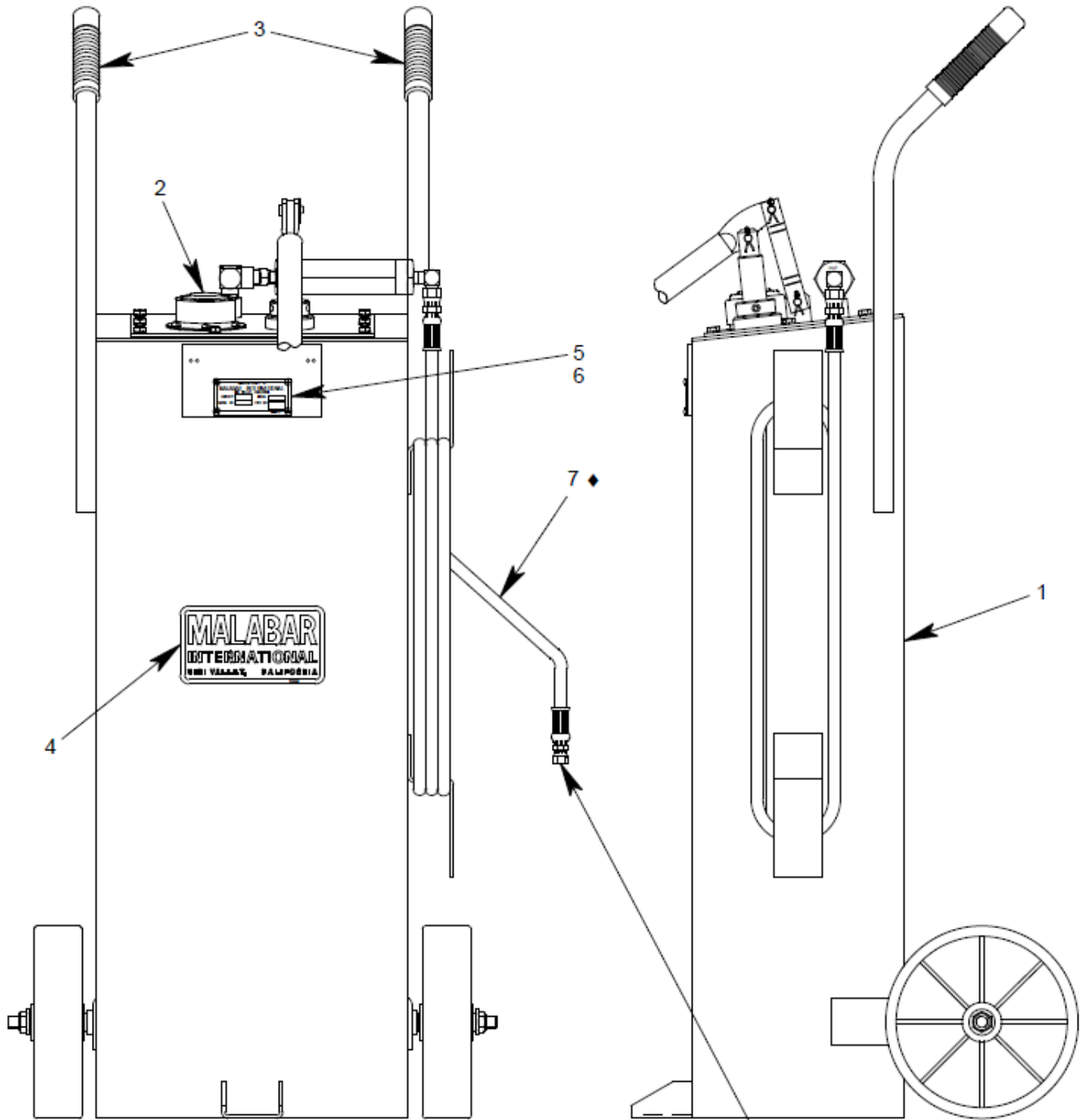

◆ PART OF REPAIR PARTS KIT

SWIVEL FEMALE SAE
 7/16-20UNF THREAD
 37° FLARE

Parts List – Figure 1A

When ordering replacement parts/kits, please specify model, serial number and color of your unit.

Item	Part Number	Description	Qty
1	PF53452	TANK	1
2	PF55447	FILLPORT ASSY	1
3	494-006	HANDLE GRIP	2
4	55998	STICKER, MALABAR	1
5	55997-2	NAMEPLATE	1
6	397-010	SELF TAPPING SCREW, 6-32	4
7	PF55456	HOSE ASSEMBLY	1

Parts List – Figure 1B

When ordering replacement parts/kits, please specify model, serial number and color of your unit.

◆ PART OF REPAIR PARTS KIT

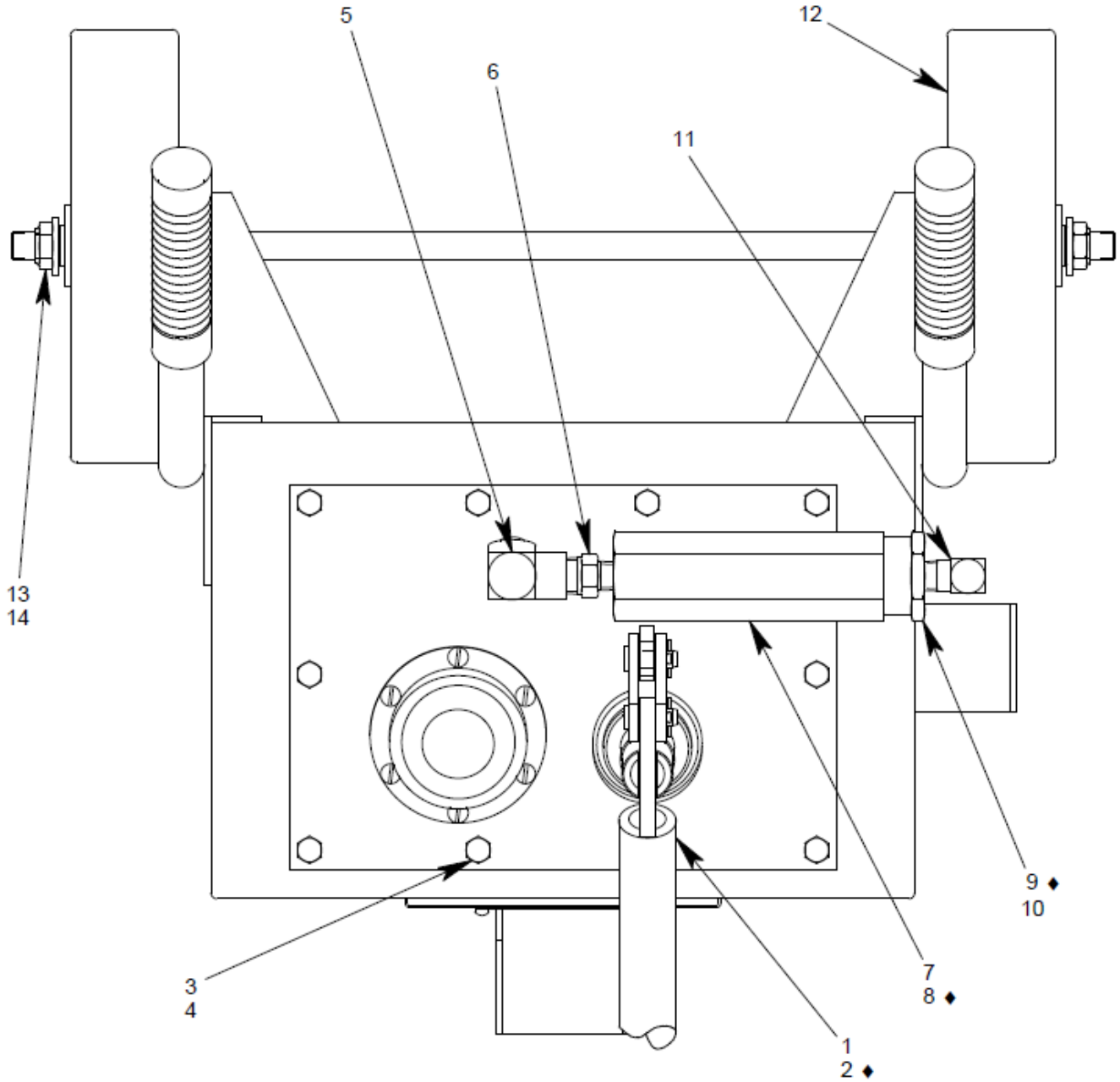

Parts List – Figure 1B

When ordering replacement parts/kits, please specify model, serial number and color of your unit.

Item	Part Number	Description	Qty
1	PF55485-1	PUMP ASSEMBLY	1
2	PF53456	GASKET	1
3	321-134	HHCS, 1/4-28 x 5/8 LG	10
4	363-001	SPLIT LOCKWASHER, 1/4	10
5	712-017	ELBOW, STREET, 3/8 NPT	1
6	711-030	NIPPLE, 3/8 NPT x 1/4 NPT	1
7	PF101161	FILTER HOUSING	1
8	481-006	FILTER ELEMENT	1
9	55925-025	O-RING	1
10	PF101163	FILTER HOUSING ENDCAP	1
11	722-005	ELBOW, 1/4 NPT x 3/8 37°	1
12	492-002	WHEEL	2
13	362-005	FLAT WASHER, 1/2	2
14	355-011	HEX LOCKNUT, 1/2-13	2

Parts List – Figure 2

When ordering replacement parts/kits, please specify model, serial number and color of your unit.

◆ PART OF REPAIR PARTS KIT

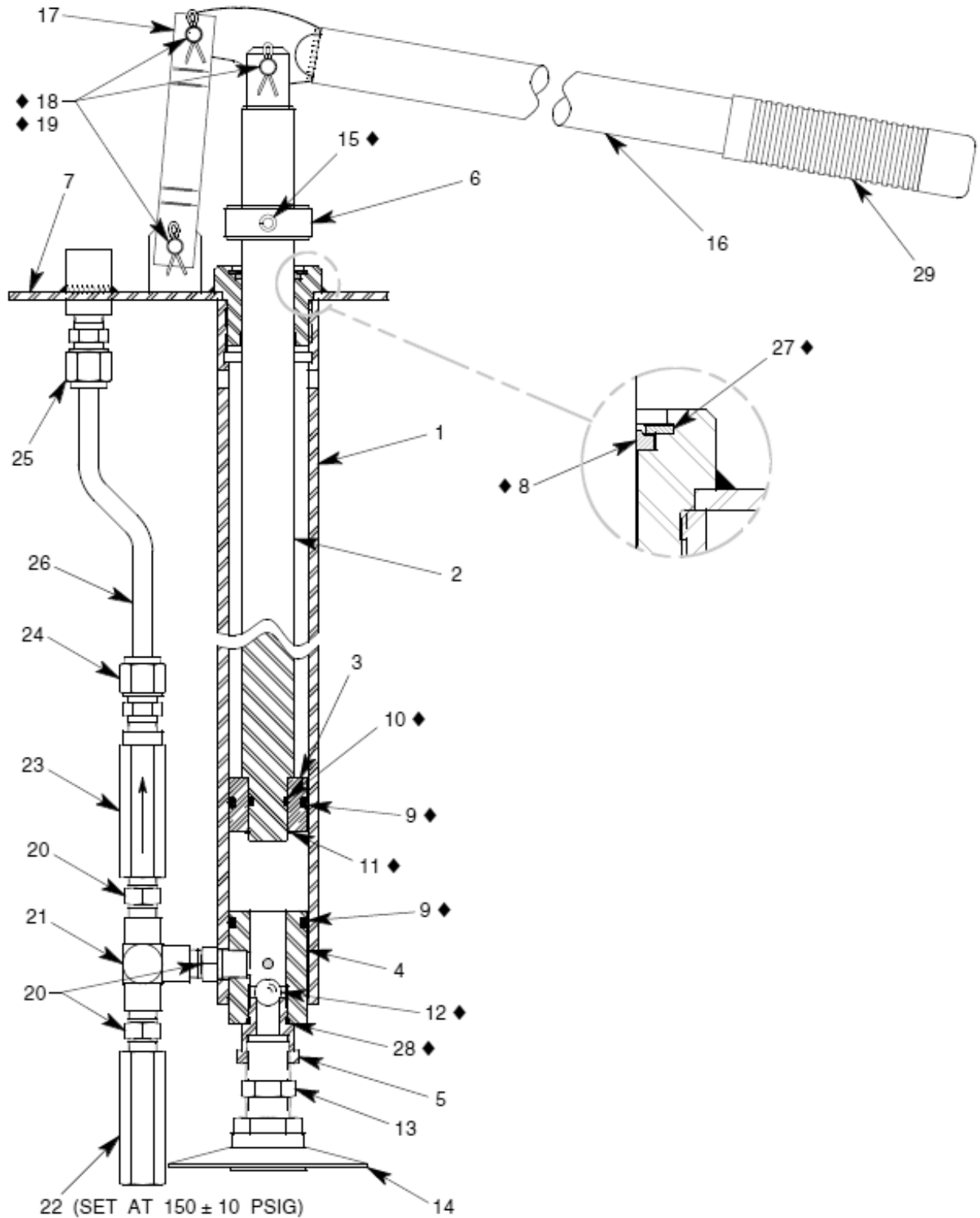

Parts List – Figure 2

When ordering replacement parts/kits, please specify model, serial number and color of your unit.

Item	Part Number	Description	Qty
	PF55485-1	PUMP ASSEMBLY; consists of:	
1	PF55486	CYLINDER	1
2	PF55487	PLUNGER	1
3	PF55488	PISTON	1
4	PF55489	VALVE BODY	1
5	PF55490	ADAPTER	1
6	PF55491	COLLAR	1
7	PF55492	COVER	1
8	55911-9	SCRAPER	1
9	55925-218	O-RING	2
10	55925-112	O-RING	1
11	55924-75	RETAINING RING	1
12	412-006	STEEL BALL, 1/2 DIA	1
13	711-001	NIPPLE, 1/2 NPT	1
14	481-002	OIL SCREEN	1
15	371-007	ROLL PIN, 5/16 DIA x 29/32 LG	1
16	PF55495	HANDLE	1
17	55615	PUMP LINK	1
18	373-008	FLAT HEAD PIN, 5/16 DIA	3
19	372-001	COTTER PIN, 3/32 x 3/4 LG	3
20	711-003	NIPPLE, 1/4 NPT	3
21	713-002	TEE, 1/4 FPT	1
22	423-002	RELIEF VALVE	1
23	422-013	CHECK VALVE	1
24	721-009	CONNECTOR, 1/4 NPT x 3/8 T	1
25	721-010	CONNECTOR, 3/8 NPT x 3/8 T	1
26	732-002	TUBING, 3/8 OD	1
27	55926-137	RETAINING RING	1
28	MS28778-8	O-RING	1
29	494-002	HANDLE GRIP	1

Parts List – PF15-2PK Repair Parts Kit

When ordering replacement parts/kits, please specify model, serial number and color of your unit.

Part Number	Description	Qty
PF55456	HOSE ASSEMBLY	1
PF53456	GASKET	1
481-006	FILTER ELEMENT	1
55925-025	O-RING	1
55911-9	SCRAPER	1
55925-218	O-RING	2
55925-112	O-RING	1
55924-75	RETAINING RING	1
412-006	STEEL BALL, 1/2 DIA	1
371-007	ROLL PIN, 5/16 DIA x 29/32 LG	1
373-008	FLAT HEAD PIN, 5/16 DIA	3
372-001	COTTER PIN, 3/32 DIA x 3/4 LG	3
55926-137	RETAINING RING	1
MS28778-8	O-RING	1