

Model: 8970
Single Stage Universal
Hydro – Mechanical
Aviation Tripod jack

02/2026 – Rev. 02

For Spare Parts, Operations & Service Manuals or Service Needs
Scan the QR code or visit tronair.com/pages/tronair-information-center



The Tronair Group of Companies: Tronair | Columbus Jack | Eagle | Malabar International

Malabar International

1 Air Cargo Pkwy East
Swanton, OH 43558

Phone: (419) 866-6301 | 800-426-6301

Web: www.tronair.com
Email: sales@tronair.com

REVISION	DATE	TEXT AFFECTED
01	10/2018	Original release
02	02/2026	Modified 8.2 Recommended Spare Parts List and Figure 2 Parts List

TABLE OF CONTENTS

PAGE

1.0	PRODUCT INFORMATION	4
1.1	DESCRIPTION.....	4
1.2	MODEL & SERIAL NUMBER.....	4
1.3	MANUFACTURER.....	4
1.4	SPECIFICATIONS	4
2.0	SAFETY INFORMATION.....	4
2.1	USAGE AND SAFETY INFORMATION.....	4
3.0	PREPARATION PRIOR TO FIRST USE	5
4.0	TRAINING.....	5
4.1	TRAINING REQUIREMENTS	5
4.2	TRAINING PROGRAM	5
4.3	OPERATOR TRAINING	5
5.0	OPERATION.....	6
5.1	PRE OPERATION INSPECTION.....	6
5.2	OPERATING PROCEDURES.....	6
6.0	TROUBLE SHOOTING.....	7
7.0	MAINTENANCE.....	8
7.1	SERVICING	8
7.2	DISASSEMBLY INSPECTION.....	8
7.3	REPAIR AND REPLACEMENT	8
7.4	TESTING:	8
8.0	PROVISION OF SPARES.....	9
8.1	SOURCE OF SPARE PARTS.....	9
8.2	RECOMMENDED SPARE PARTS LISTS	9
9.0	IN SERVICE SUPPORT.....	10
10.0	GUARANTEES/LIMITATION OF LIABILITY.....	10
11.0	APPENDICES	10

This product can not be modified without the written approval of Tronair, Inc. Any modifications done without written approval voids all warranties and releases Tronair, Inc., its suppliers, distributors, employees, or financial institutions from any liability from consequences that may occur. Only Tronair OEM replacement parts shall be used.



CAUTION!

Aircraft manufacturer's specifications and instructions must be followed. In the event of contradiction between aircraft manufacturer's specifications and Malabar's, aircraft manufacturer's will prevail.

1.0 PRODUCT INFORMATION

1.1 DESCRIPTION

The Malabar Fixed Height Tripod Jack Model 8970 is a 40 ton capacity single stage hydraulic jack designed primarily for use in aircraft maintenance. The 8970 also features a mechanical extension with integrated lifting ring allowing for use on aircraft with significantly differing jack point elevations. It consists of a tripod structure with hydraulic cylinder assembly, operator platform, foot-actuated pneumatic pump, load gauge, hand pump, height adjustable swivel casters, height adjustable leveling footpads, cast steel locknut with handwheel, and the following optional equipment:

- Forklift tubes

The jack tow handle readily connects to tow vehicle for ease of transport. The jack should never be used as a personnel carrier while being towed or in motion. The jack is supported by three adjustable spring loaded swivel casters for transport and positioning. Additionally, the adjustable footpads can be retracted to increase the towing ground clearance or extended to contact the ground and plumb the jack prior to jacking. These features enable the model 8970 can be deployed rapidly and effectively on flat or uneven surfaces.

1.2 MODEL & SERIAL NUMBER

Reference nameplate on unit

1.3 MANUFACTURER

TRONAIR, Inc./Malabar International
1 Air Cargo Pkwy East
Swanton, Ohio 43558 USA

Telephone: (419) 866-6301 or 800-426-6301
Fax: (419) 867-0634
E-mail: sales@tronair.com
Website: www.tronair.com

1.4 SPECIFICATIONS

Rated Capacity	40 tons (36.3 m. tons)
Side Load	15% of vertical load
Low Height	71 in (1803 mm)
Hydraulic Lift	54 in (1372 mm)
Mechanical Extension	47.5 in (1207 mm)
Total Extended Height with Mechanical Extension Retracted	125 in (3175 mm)
Total Extended Height with Mechanical Extension Extended	172.5 in (4382 mm)
Oil Pressure at Rated Capacity	1695 psig (119 kg/sq cm)
Safety Pop-off Valve set at	44 ton (39.9 m. tons)
Proof Load	60 ton (54.4 m. tons)
Reservoir Capacity	12.7 gal (48.1 l)
Hydraulic Fluid	MIL-PRF-5606 or equivalent
Maximum Towing Speed	5 mph (8 km/h)
Approximate Jack Net Weight	2300 lbs (1043 kg)

2.0 SAFETY INFORMATION

2.1 USAGE AND SAFETY INFORMATION

To ensure safe operations please read the following statements and understand their meaning. Also refer to your equipment manufacturer's manual for other important safety information. This manual contains safety precautions which are explained below. Please read carefully.



WARNING!

Warning is used to indicate the presence of a hazard that can cause **severe personal injury, death, and/or substantial property damage** if the Warning Notice is ignored.



CAUTION!

Caution is used to indicate the presence of a hazard, which will or can cause **minor personal injury or property damage** if the Caution Notice is ignored.

3.0 PREPARATION PRIOR TO FIRST USE

Disregard the following erection procedure if the jack is shipped fully assembled. If the jack is shipped partially assembled, erection is accomplished by following the suggested sequence below (also see figures 1A, 1B, 1C and 1D):

1. Install sling under tripod head of cylinder assembly and support from a crane or forklift capable of lifting 3000 pounds to a height of 14 feet.
2. Install legs, tripod head pins and retaining rings.
3. Install braces.
4. Tighten all bolts.
5. Before placing jack in operation, perform the following procedure:
6. Remove the breather from the filler spout located at the top of the reservoir.
7. Fill jack reservoir approximately 1/2 to 1 inch below filler spout with MIL-PRF-5606 hydraulic fluid or approved equivalent (reservoir capacity is approximately 12.7 gallons/48.1 liters). Jack plunger must be fully retracted before filling reservoir. Replace breather.
8. Open release valve (located next to the spirit level) and operate hand pump a few strokes to bleed all air trapped under hand pump.
9. Close release valve and operate hand pump to raise plunger approximately 1 inch.
10. Open release valve to retract plunger fully to bleed all air trapped under jack plunger. Close release valve.

4.0 TRAINING

4.1 TRAINING REQUIREMENTS

The employer of the operator is responsible for providing a training program sufficient for the safe operation of the unit.

4.2 TRAINING PROGRAM

The employer provided operator training program should cover safety procedures concerning use of the unit in and around the intended aircraft at the intended aircraft servicing location.

4.3 OPERATOR TRAINING

The operator training should provide the required training for safe operation of the unit.

NOTE: Maintenance and Trouble Shooting are to be performed by a skilled and trained technician.

5.0 OPERATION

5.1 PRE OPERATION INSPECTION

Each time the jack is to be used, inspect the following:

1. Check the tripod structure for rigidity. Make sure all bolts are tightened.
2. Check hydraulic line connections for leaks. Tighten as required.
3. Check for hydraulic fluid leaks around the base, reservoir, cylinder top, air pump (if so equipped) and hand pump.
4. Check hand pump for proper operation.
5. Check swivel casters for proper operation.
6. Check reservoir fluid level with jack plunger fully retracted.

5.2 OPERATING PROCEDURES

1. If the mechanical extension is required to raise the aircraft, perform the following procedure:
 - a. Use a forklift to lift up the mechanical extension until the groove for clamping the extension is exposed (at a height around 47.5 inches).
 - b. Clamp the mechanical extension tight per figure 2.
2. Position the jack under the jacking pad of the aircraft
3. Verify the jack is leveled (shim footpads if necessary). The jack plunger should be plumb during lifting.



CAUTION!

The jack is equipped with an air pump. Air relief valve must be installed at all times. If air relief valve is removed, it is possible to over pressurize the pneumatic system which could cause equipment failure and possible bodily injury.

4. The jack is equipped with an air pump. Connect air supply (90-110 psig) to the 1/2 NPT air inlet at the air valve (A minimum of 28 scfm is required). Air relief valve must be properly installed. Do not attempt to remove air relief valve.



CAUTION

Locknut must be installed and operable on jack at all times. Always maintain less than 2 in (5 cm) between the locknut and the tripod head in all phases of load raising and lowering.

1. To raise the load:
 - a. The jack is equipped with an adjustable hand pump. The hand pump handle length can be varied by inserting the quick release pin through the clamp and appropriate hole along the handle (see figure 3). A longer handle length provides greater pumping leverage for high pressure pump operation. A shorter handle will increase the plunger stroke and allow more oil pumped per stroke. This permits a more rapid raising of the jack plunger under a light or no load.
 - b. Close the release valve located next to the spirit level.
 - c. Operate the air valve or hand pump until the ship adapter contacts the jacking pad. Ensure the ship adapter and the jacking pad are correctly mated. The load may now be raised by operating the air valve or hand pump.
 - d. Do not lift a load greater than the rated capacity of 40 tons.
 - e. Do not attempt to raise the plunger beyond the rated hydraulic lift (54 inches maximum).
 - f. Avoid lifting with excessive side load on the jack.
 - g. Spin the locknut down to the tripod head, as plunger is extending.
 - h. Keep the release valve closed at all times.
2. To lower the load:
 - a. Operate the air valve or hand pump to relieve pressure on the locknut.
 - b. Spin the locknut out of the way.
 - c. Slowly open release valve located next to the load gauge to lower the load. The speed of lowering is controlled by the amount the release valve is opened.
 - d. Close release valve after the plunger is fully retracted.
 - e. To lower the mechanical extension, use a forklift to lift it up to relieve the clamps, loosen the fasteners to remove the claps, and then slowly lower the extension into the plunger
 - f. Cover the jack when not in use to prevent entrance of contaminants and water into the cylinder.

6.0 TROUBLE SHOOTING

TROUBLE	PROBABLE CAUSE	REMEDY
Jack will not raise	Release valve open (Oil passing back into reservoir)	Close valve firmly
	Intake valve open. (Oil passing back into reservoir)	Pump rapidly to flush dirt off
	Discharge valve open (Oil passing back into pump chamber)	Pump rapidly to flush dirt off
	Sticking intake valve	Remove pump from jack base. Unscrew valve block. Clean or replace valve
	Clogged screen	Remove and clean
	Lack of oil. Air under plunger	Refill. Check for leaks. Bleed air out by opening release valve. Pump rapidly a few times and close release valve
Jack will not raise to full height	Lack of oil	Refill, check for leaks
	Sticking intake valve	Remove pump from jack base. Unscrew valve block. Clean or replace ball valves. Re-tighten or repair
Jack will not raise capacity load	High pressure leaks (At pump or release valve)	Reseat valve
	Leaky release valve	Reseat valve and clean valve block
Jack raises and falls during each stroke	Leaky discharge valve	Tighten or replace ball valve or packing
Jack will not hold up load	Leaky release valve	Reseat valve
	Defective "O" ring and back up ring	Remove plunger and replace "O" ring and back up ring
Jack will not lower the load	Damaged release valve	Remove and replace parts as needed
	Bent plunger	Replace
Jack will not close completely	Air under plunger	Bleed air out. Open release valve and pump rapidly several times. Close valve
Handle stroke only partly effective	Air in pump chamber	Open release valve and pump rapidly several times. Close valve
	Sticking intake valve	Remove pump and clean valve block
	Clogged screen	Remove and clean
Handle raises without effort	Leaky intake valve	Remove pump and clean valve block
Handle snaps back	Sticking intake valve	Open release valve. Pump rapidly several times. Close valve
	Clogged screen	Remove and clean

7.0 MAINTENANCE**7.1 SERVICING**

Servicing the jack consists primarily of the following:

1. When in use, the reservoir should be kept at the proper level with hydraulic fluid MIL-PRF-5606 or approved equivalent. Always check fluid level with jack plunger fully retracted.
2. Grease the swivel casters.
3. Lubricate hand pump pivot pins.
4. If the jack has been put into storage or has not been used, the plunger must be fully extended and retracted every 90 days to exercise the seals. A portion of the lift should be operated by the air pump and a portion by the hand pump.

7.2 DISASSEMBLY INSPECTION**CAUTION!**

Safety pop-off valve, located on the hand pump valve block, should not be removed unless absolutely necessary. The valve is set to by-pass hydraulic fluid back to the reservoir at 5-10% above the rated capacity of 40 tons. If adjustment is required, see procedure under testing (see below).

When necessary to disassemble the jack, drain all hydraulic fluid from reservoir and carefully inspect the following:

1. Inspect interior walls of jack cylinder and hand pump cylinder for smoothness and freedom from rust, nicks, scratches and excessive wear.
2. Check plunger, mechanical extension, cylinder, tripod head, etc., for corrosion, wear and condition of threads.
3. Inspect packings, seals, gaskets and wipers in the cylinder assembly and hand pump for cuts, scratches, deterioration and distortion.
4. Inspect upper bearing for excessive scoring and/or wear.
5. Check oil screen in the y-strainer located under the reservoir for cleanliness.
6. Inspect valves and valve seats in the hand pump for scratches, dents and proper seating of the balls.
7. Inspect all pivot pins for wear, cracks, pits or evidence of damage or pending damage.
8. Check tripod structure for damages.
9. Inspect all areas for excessive dirt, oil, dust and chips.

7.3 REPAIR AND REPLACEMENT

No definite time schedule can be established for the overhaul of the jack for replacement of the various moving parts. The number of times the jack is raised and lowered and the amount of load raised at each operation materially affect the life of the working parts. Do not overload the jack. Overloading is dangerous, will hasten the need for overhaul and may damage the jack. During overhaul, replace all parts that do not pass disassembly inspection requirements. Regardless of apparent condition, replace all parts marked with (♦) in the parts breakdown. A repair parts kit (P/N 8970PK) which contains all of the parts marked with (♦) is available and recommended to keep on hand at your facility. Coat all O-rings and back-up rings with hydraulic fluid MIL-PRF-5606 prior to assembly. Clean all metal parts with clean solvent and dry with compressed air. Lubricate all threads. Use teflon tape carefully on all pipe threads. Remove excess tape because it can clog valves and passages. If ball valves, located in the pump valve body, do not seat properly, they may need to be reseated by tapping the ball into the valve seat with a brass rod cupped at one end.

7.4 TESTING:

Place jack in a load indicating test fixture. Make sure the test adapter is 3/4 inch male spherical radius. Operate hand pump to extend plunger against the test adapter. Make sure ship adapter and test adapter are correctly mated. Load test the jack at rated capacity of 40 tons. If the jack fails to operate properly, check for trouble as indicated in the Trouble Shooting Chart (see sheet 7). With the plunger extended and supporting the capacity load, allow the jack to stand for 10 minutes. Any excess settling indicates leakage in the hand pump, release valve, safety pop-off valve, air pump, or jack packing seals. Check for hydraulic fluid leaks and replace all defective parts.

If adjustment is required for the safety pop-off valve, perform the following procedure:

1. Close release valve (figure 1B, item 33).
2. Place jack in a load indicating test fixture. Make sure the test adapter is 3/4 inch male spherical radius. Operate hand pump to extend plunger against the test adapter. Make sure ship adapter and test adapter are correctly mated.
3. While operating the hand pump, adjust the safety pop-off valve set screw (figure 1D, item 49) until it by-passes hydraulic fluid back to the reservoir at 42.0 to 44.0 tons.
4. Once more operate hand pump to verify correct setting.
5. Open release valve to relieve pressure.

8.0 PROVISION OF SPARES

8.1 SOURCE OF SPARE PARTS

Spare parts may be obtained from the manufacturer:

TRONAIR , Inc.	Telephone: (419) 866-6301 or 800-426-6301
1 Air Cargo Pkwy East	Fax: (419) 867-0634
Swanton, Ohio 43558 USA	E-mail: sales@tronair.com
	Website: www.tronair.com



For Spare Parts, Operations & Service Manuals or Service Needs:
Scan the QR code or visit tronair.com/pages/tronair-information-center

8.2 RECOMMENDED SPARE PARTS LISTS

The following spare parts are recommended and available upon request. Reference the following page(s) for Replacement Parts and Kits available.

Part Number	Description	Qty
8970PK	Repair parts kit	1
55320B	Hand pump assembly	1
55762-9	Pump handle	1
85416	Release valve	1
897039	Valve block	1
423-053	Relief valve cartridge	1
897062	Breather cap with dipstick	1
894218	Sticker, instruction	1
55994	Sticker, fluid	1
75940	Sticker, towing	1
894219	Sticker, identification	1
897080	Sticker, max. capacity	1
75938	Sticker, CE	1
888380	Sticker, footpad	1
73334A	Spring loaded swivel caster	3
897015	Upper bearing	1
888221	Ship adapter	1
897010	Ship adapter	1
897025	Ship adapter	1
79595	Rain hat	1
494-039	Handle grips	12
421-055	Air valve	1
425-001	Air relief valve	1
441-002	Air operated hydraulic pump	1
441-038	Seal kit, air pump	1
471-001	Lubricator	1
499-002	Muffler	1
481-004	Y strainer	1
897098	Load gauge	1

9.0 IN SERVICE SUPPORT

Contact Malabar, Inc. for technical services and information.

10.0 GUARANTEES/LIMITATION OF LIABILITY

- I. Seller warrants each new product of its manufacture to be free from defects in material or workmanship, under proper, reasonable, and normal use and service.
- II. The warranty period shall be as follows:
 - A. For Malabar equipment, with the exception of Tripod Jacks, the warranty period is one (1) year after date of shipment.
 - B. For Malabar Tripod Jacks, the warranty period is three (3) years after date of shipment.
- III. Where Buyer claims an alleged defect in material or workmanship and so advises Seller in writing within ten (10) days after discovery thereof, then and in such event, Buyer shall return said equipment, transportation prepaid, to the Seller, provided such return is timely and within the above-mentioned warranty period. This warranty and liability of the Seller is expressly limited solely to replacement or repair of defective parts or goods, and return at Buyer's expense to Buyer after finding by Seller the product was defective prior to original shipment or, at the option of Seller, to providing refund to Buyer of the purchase price for said product.
- IV. It is further expressly understood and agreed that:
 - A. THERE IS NO WARRANTY, REPRESENTATION OF CONDITION OF ANY KIND, EXPRESS OR IMPLIED, (INCLUDING NO WARRANTY OF MERCHANTABILITY OR OF FITNESS) EXCEPT THAT THE MATERIAL SHALL BE OF THE QUALITY SPECIFIED IN APPLICABLE SPECIFICATIONS, AND NONE SHALL BE IMPLIED BY LAW. Except as otherwise provided herein, quality shall be in accordance with Seller's specifications. Final determination of the material for the use contemplated by Buyer is the sole responsibility of Buyer and Seller shall have no responsibility in connection with such suitability, and
 - B. Buyer's sole and exclusive remedy shall be repair or replacement of defective parts or goods by the Seller. Should the goods, in the judgment of Seller, preclude the remedying of the warranted defects by repair or replacement, the Buyer's sole and exclusive remedy shall be the refund of the purchase price, and
 - C. Seller shall not be liable for prospective profits or special, indirect or consequential damages, nor shall any recovery of any kind against Seller be greater in amount than the purchase price of the specific material sold and causing the alleged loss, damage or injury. Buyer assumes all risk and liability for loss, damage or injury to persons or property of Buyer or others arising out of use or possession of any product or part sold hereunder, and
 - D. Seller shall in no way be deemed or held to be obligated, liable or accountable upon or for any guarantees or warranties, express or implied, or created by statute or by operation of law or otherwise, in any manner of form beyond its express agreement above set forth, and
 - E. No warranty herein shall apply to any product which shall have been repaired or altered, unless such alteration or repair has been made by Seller or if, after return to and inspection by Seller, the product is found by Seller to have been subject to misuse, negligence or accident, and
 - F. No warranty of any nature is made by Seller as to any component forming a part of the product sold and Buyer shall receive only such warranties offered by such other manufacturer of such component, and
 - G. Seller does not assume nor does Seller authorize any other person to assume for it any other liability or make any warranty in connection with the sale of its products.

11.0 APPENDICES

APPENDIX I Safety Data Sheet – MIL-PRF-5606 Hydraulic Fluid

Pneumatic / Hydraulic Diagram

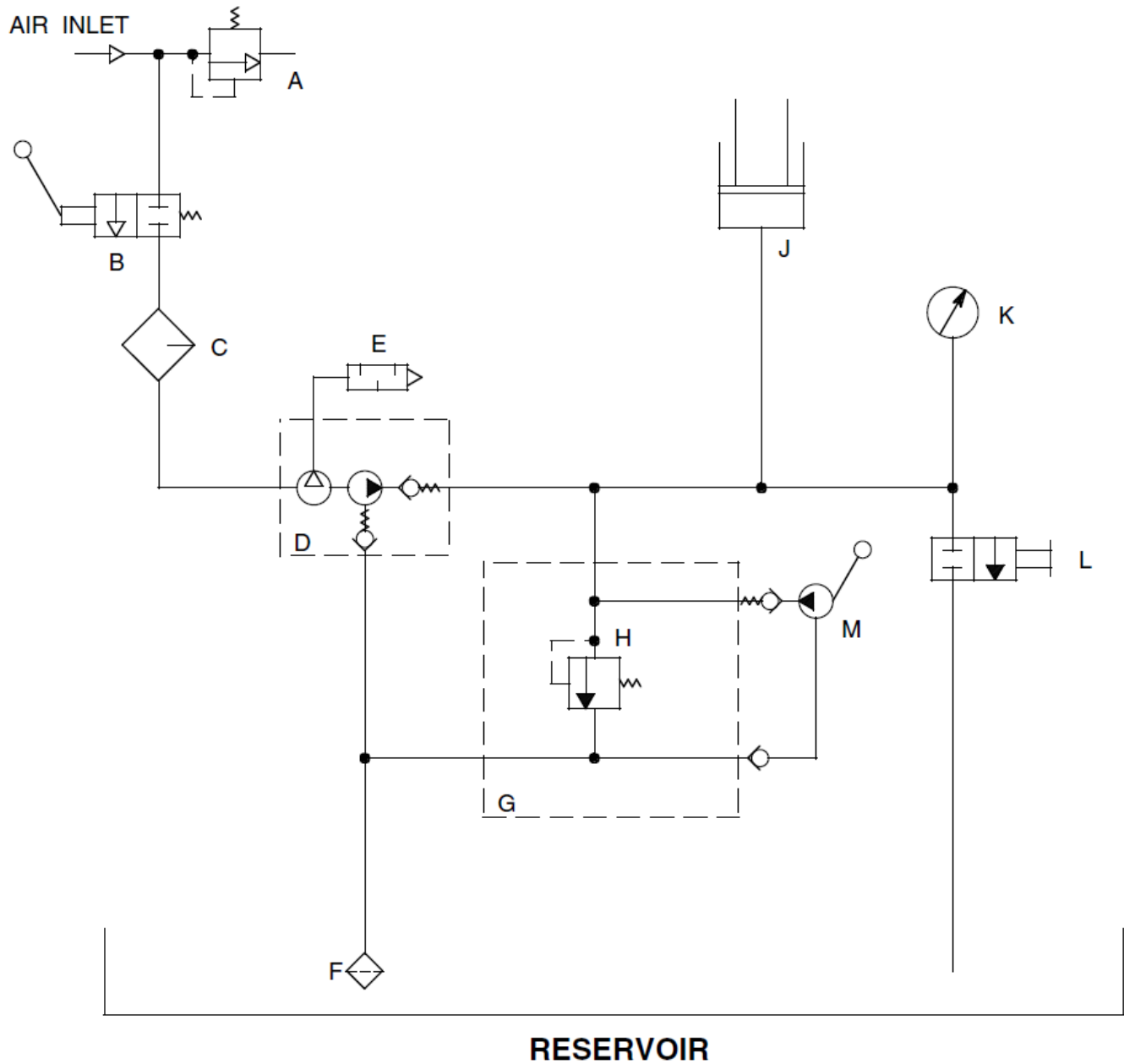

- A - AIR RELIEF VALVE
- B - AIR VALVE
- C - LUBRICATOR
- D - AIR PUMP
- E - MUFFLER
- F - OIL SCREEN

- G - VALVE BLOCK
- H - SYSTEM RELIEF VALVE
- J - CYLINDER ASSEMBLY
- K - LOAD GAUGE
- L - RELEASE VALVE
- M - HAND PUMP

Parts List – Figure 1A

When ordering replacement parts/kits, please specify model, serial number and color of your unit.

◆ PART OF REPAIR PARTS KIT

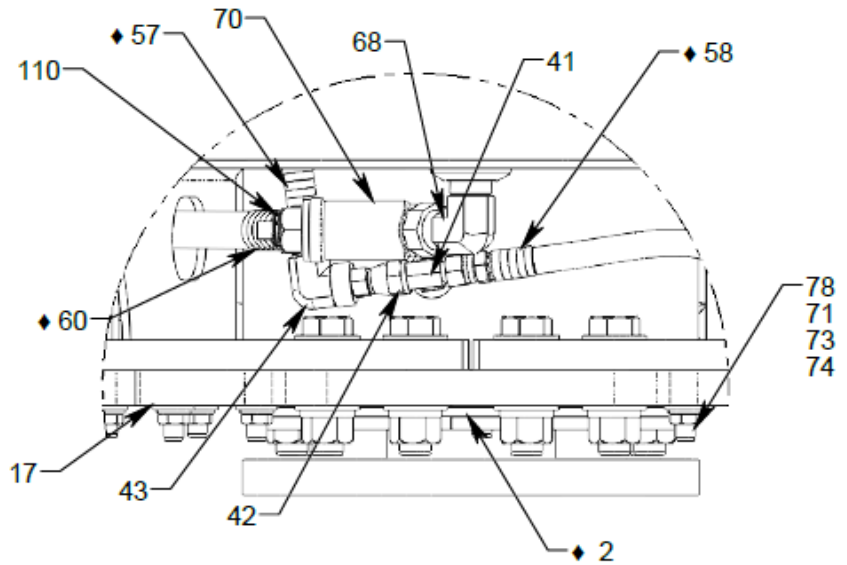

DETAIL A
SCALE 1 : 4

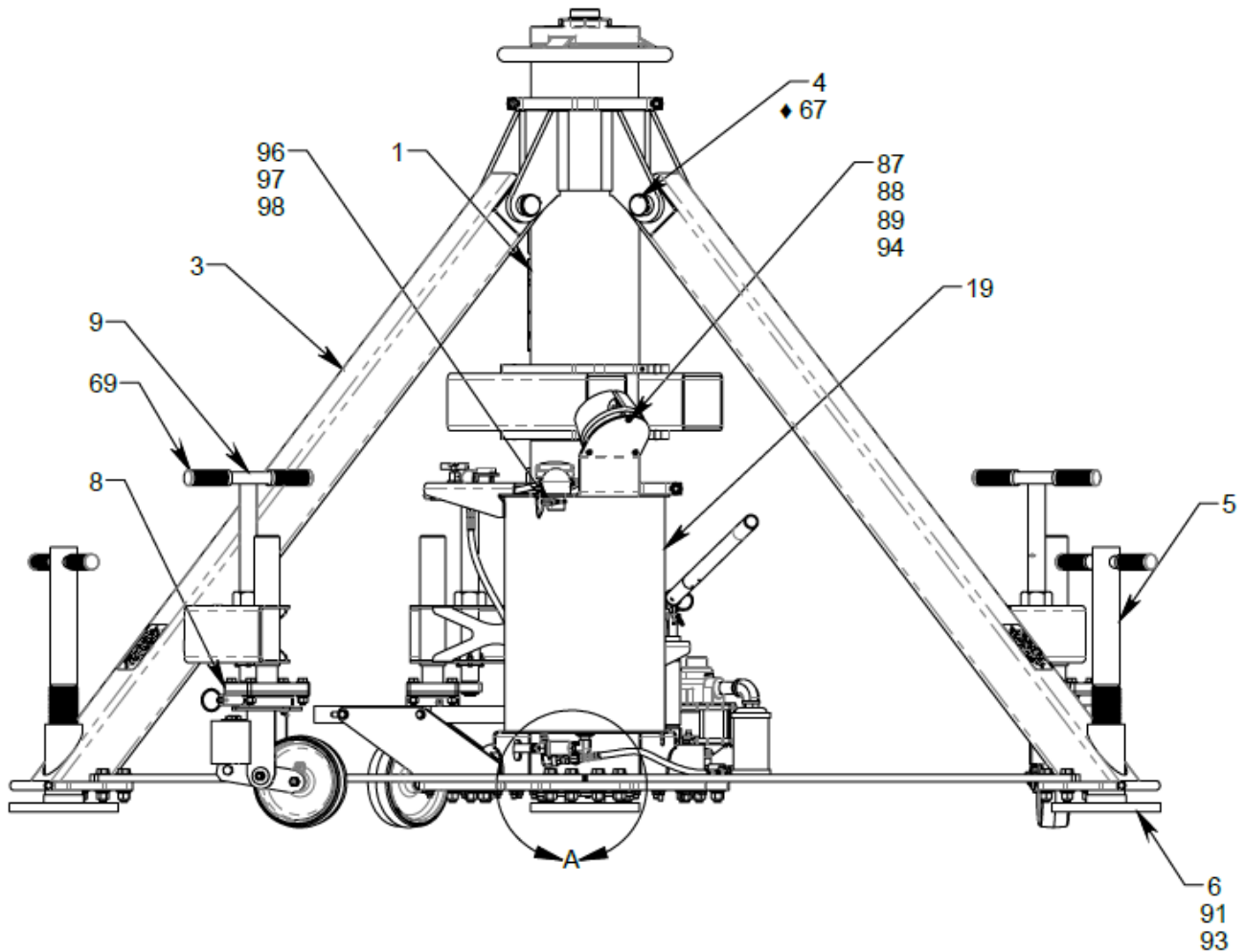

Parts List – Figure 1B

When ordering replacement parts/kits, please specify model, serial number and color of your unit.

◆ PART OF REPAIR PARTS KIT

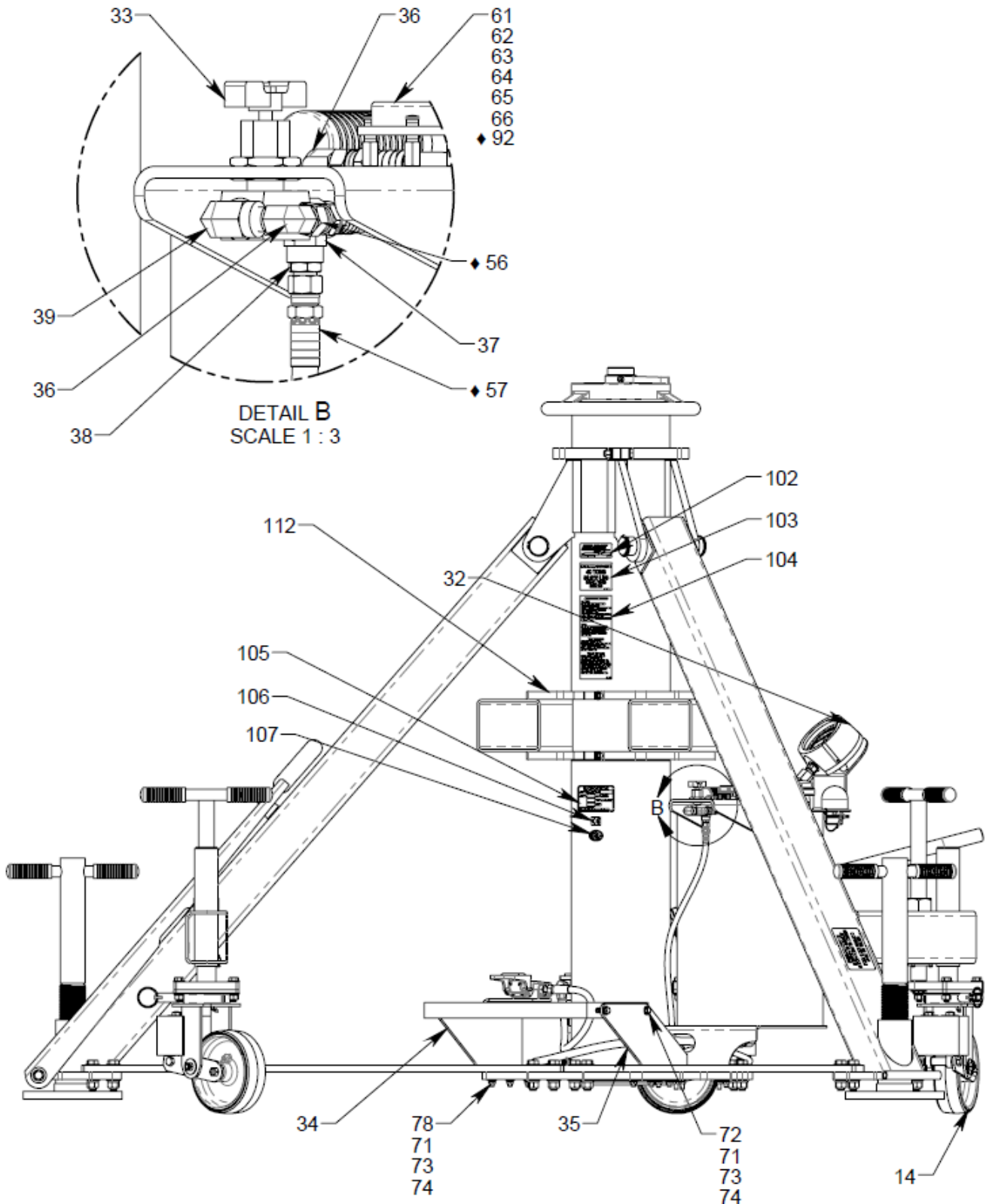

Parts List – Figure 1C

When ordering replacement parts/kits, please specify model, serial number and color of your unit.

◆ PART OF REPAIR PARTS KIT

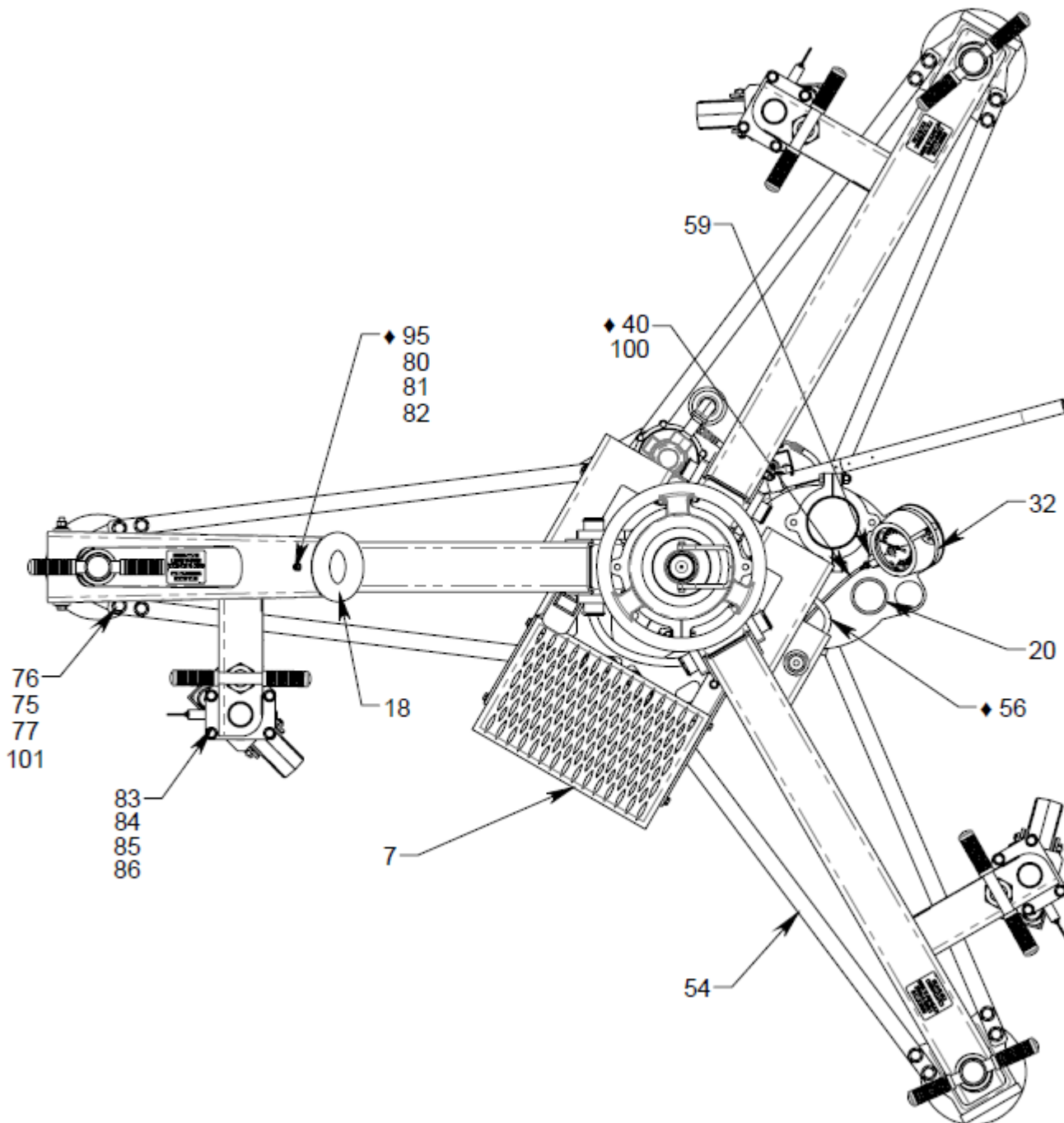

Parts List – Figure 1D

When ordering replacement parts/kits, please specify model, serial number and color of your unit.

◆ PART OF REPAIR PARTS KIT

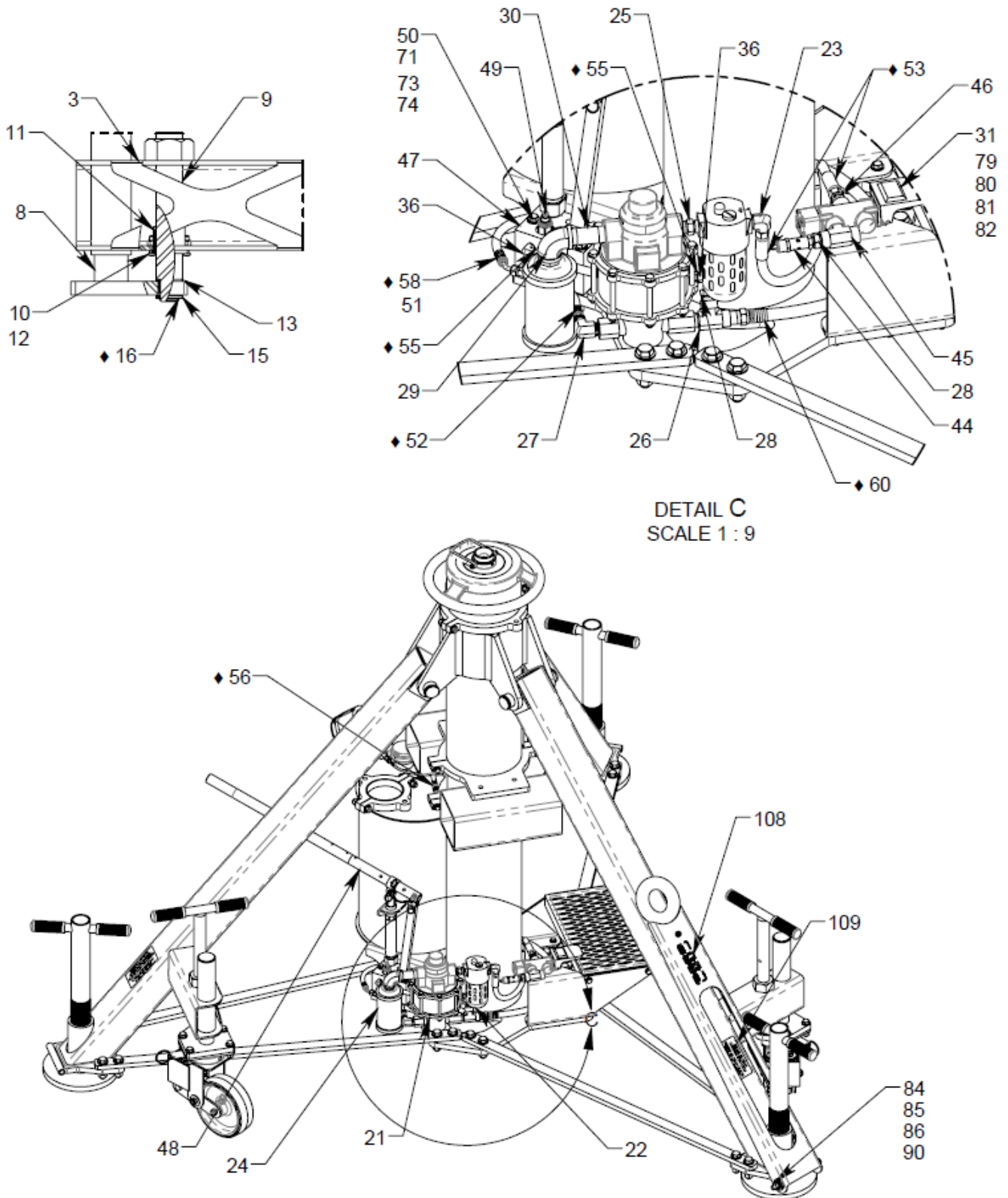

Parts List – Figure 1A-1D

When ordering replacement parts/kits, please specify model, serial number and color of your unit.

Item	Part Number	Description	Qty
1	897099	CYLINDER ASSEMBLY	1
2	55917-925-S02	SNAP RING	1
3	897020	LEG WELDMENT	3
4	897022	PIN	3
5	897023	FOOT SCREW WELDMENT	3
6	897031	FOOT PAD WELDMENT	Ar
7	493-015	STEP	1
8	897051	CASTER MOUNT WELDMENT	3
9	897052	T-HANDLE WELDMENT	3
10	326-009	BHCS, 1/4-20 x 1" LG	9
11	410-024	BEARING, FLANGED, 1.5" DIA OVERSIZED	3
12	353-001	HEX LOCKNUT, 1/4-20	9
13	410-025	BEARING, FLANGED, 1" DIA	3
14	73334A	SPRING LOADED SWIVEL CASTER	3
15	410-026	BEARING, 1" DIA	3
16	55923-100	RETAINING RING	3
17	897009	BASE PLATE	1
18	897038	TOWBAR WELDMENT	1
19	897037	RESERVOIR WELDMENT	1
20	897062	BREATHER CAP WITH DIPSTICK	1
21	441-002	AIR OPERATED HYDRAULIC PUMP	1
22	471-001	LUBRICATOR	1
23	712-082	ELBOW, 90°, 1/2 MPT x 1/4 MPT	1
24	499-002	MUFFLER	1
25	711-004	NIPPLE, 1/2 MPT	1
26	713-029	TEE, RUN, 1/2 NPT	1
27	722-002	ELBOW, 90°, 3/8 M 37° x 1/2 MPT	1
28	714-003	REDUCER, 1/2 MPT x 1/4 FPT	2
29	712-063	ELBOW, 3/4 FPT x 3/4 FPT, BRASS	1
30	711-010	NIPPLE, BRASS, 3/4 MPT x 3" LG	1
31	421-055	AIR VALVE	1
32	897098	LOAD GAUGE	1
33	85416	RELEASE VALVE	1
34	897013	RISER, LEFT	1
35	897012	RISER, RIGHT	1
36	722-005	ELBOW, 3/8 37° x 1/4 MPT	4
37	713-012	TEE, 1/4 MPT x 1/4 FPT x 1/4 FPT	1
38	721-004	CONNECTOR, 3/8 37° x 1/4 MPT	1
39	712-008	ELBOW, 90°, 1/4 MPT x 1/4 FPT	1
40	880437-4	HYDRAULIC PRESSURE HOSE	1
41	723-047	TEE, 3/8 37° x 3/8 SAE x 3/8 37°	1
42	751-039	ADAPTER, 3/8 SWIVEL F 37° x 1/4 MPT	1
43	722-020	ELBOW, 3/8 M 37° x 1/4 FPT	1
44	425-001	AIR RELIEF VALVE, 1/4 MPT	1

Parts List – Figure 1A-1D

When ordering replacement parts/kits, please specify model, serial number and color of your unit.

Item	Part Number	Description	Qty
45	897039	VALVE BLOCK	1
46	55320B	3/4" ADJUSTABLE HAND PUMP ASSEMBLY	1
47	897039	VALVE BLOCK	1
48	55320B	3/4" ADJUSTABLE HAND PUMP ASSEMBLY	1
49	423-053	RELIEF VALVE CARTRIDGE	1
50	321-254	HHCS, 3/8-16 x 5" LG	3
51	723-001	TEE, 3/8 M 37° x 1/4 MPT x 3/8 M 37°	1
52	897035-1	HYDRAULIC HOSE	1
53	485-121	HYDRAULIC HOSE, 1/4 FPT, 2' LG	1
54	897055	BRACE	6
55	897035-2	HYDRAULIC HOSE	1
56	897035-3	HYDRAULIC HOSE	1
57	897035-4	HYDRAULIC HOSE	1
58	897035-5	HYDRAULIC HOSE	1
59	721-231	CONNECTOR, 1/4 37° x 1/2 FPT	1
60	897036	HYDRAULIC HOSE	1
61	79222	SPIRIT LEVEL	1
62	321-315	HHCS, #6-32 x 1/2 LG	3
63	362-052	FLAT WASHER, #6 SAE	3
64	359-039	LONG HEX NUT, #6-32	3
65	341-021	RHSS, #6-32 x 5/8 LG	3
66	363-011	SPLIT LOCKWASHER, #6	3
67	55923-175	RETAINING RING	6
68	712-074	ELBOW, 1/2 MPT	1
69	494-039	HANDLE GRIP	12
70	481-004	Y STRAINER, 1/2 NPT	1
71	361-001	FLAT WASHER, 3/8	36
72	321-008	HHCS, 3/8-16 x 1-1/4 LG	4
73	363-003	SPLIT LOCKWASHER, 3/8	19
74	351-002	HEX NUT, 3/8-16	17
75	361-002	FLAT WASHER, 5/8 SAE	48
76	321-094	HHCS, 5/8-11 x 2 1/2 LG	24
77	351-006	HEX NUT, 5/8-11	24
78	321-024	HHCS, 3/8-16 x 1-3/4 LG	10
79	321-083	HHCS, 5/16-18 x 1" LG	2
80	361-006	FLAT WASHER, 5/16 SAE	3
81	363-002	SPLIT LOCKWASHER, 5/16	3
82	351-012	HEX NUT, 5/16-18	3
83	321-169	HHCS, 1/2-20 x 2" LG	12
84	362-005	FLAT WASHER, 1/2 SAE	26
85	351-011	HEX NUT, 1/2-20	13
86	363-004	SPLIT LOCKWASHER, 1/2	13
87	323-018	SHCS, 10-32 x 1-1/2 LG	3
88	361-015	FLAT WASHER, #10 SAE	3

Parts List – Figure 1A-1D

When ordering replacement parts/kits, please specify model, serial number and color of your unit.

Item	Part Number	Description	Qty
89	363-009	SPLIT LOCKWASHER, #10	3
90	321-146	HHCS, 1/2-20 x 8" LG	1
91	330-024	SHSS, 3/8-16, 1/2 DIA x 3/8 SHLDR	3
92	390-122	#6 CUSHION WASHER	12
93	361-035	FLAT WASHER, 3/8 OVERSIZE	3
94	351-008	HEX NUT, 10-32	3
95	999-069	BUMPER	1
96	394-104	HOSE CLAMP, 1.5" I.D.	1
97	481-054	CRIMP	2
98	491-053	LANYARD x 8" LG	AR
99	321-333	HHCS, 3/8-24 x 1 1/2 LG	2
100	721-015	CONNECTOR, 1/4 MALE 37° x 1/4 MPT	1
101	363-005	SPLIT LOCKWASHER, 5/8	24
102	894219	STICKER, IDENTIFICATION	1
103	897080	STICKER, MAX. CAPACITY	1
104	894218	STICKER, INSTRUCTIONS	1
105	55994	STICKER, FLUID	1
106	75938	STICKER, CE	1
107	499-157	STICKER, MADE IN USA	1
108	75940	STICKER, TOWING	1
109	888380	STICKER, FOOTPAD	3
110	717-007	HOLLOW HEX PLUG, 3/8 MPT	1
111	79595	RAIN HAT (NOT SHOWN)	1
112	897071	FORKLIFT TUBE ASSEMBLY	1

This page left blank intentionally.

Parts List – Figure 2

When ordering replacement parts/kits, please specify model, serial number and color of your unit.

◆ PART OF REPAIR PARTS KIT

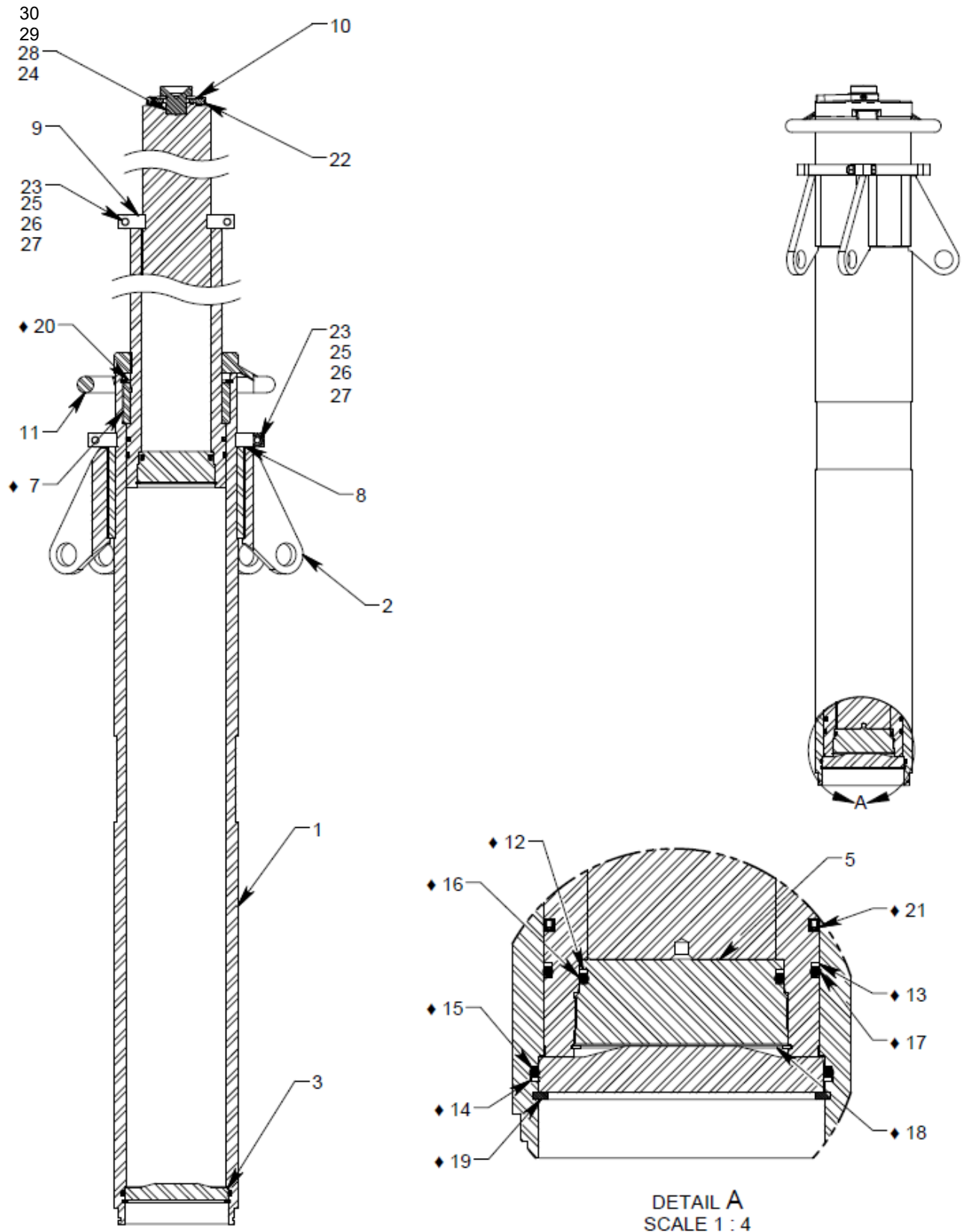

Parts List – Figure 2

When ordering replacement parts/kits, please specify model, serial number and color of your unit.

Item	Part Number	Description	Qty
	897009	Cylinder Assembly; consists of:	
1	897001	CYLINDER	1
2	897002	TRIPOD HEAD	1
3	897004	CYLINDER DIAPHRAGM	1
4	897005	PLUNGER	1
5	897007	PLUNGER DIAPHRAGM	1
6	897008	MECHANICAL EXTENSION	1
7	897015	UPPER BEARING	1
8	897081	RING HALF	2
9	897082	RING HALF	2
10	897083	SHACKLE	1
11	897084	HAND WHEEL LOCKNUT	1
12	55920-431	BACK-UP RING, TEFLON	1
13	55920-442	BACK-UP RING, TEFLON	1
14	55920-445	BACK-UP RING, TEFLON	1
15	55925-445	O-RING	1
16	55925-431	O-RING	1
17	55925-442	O-RING	1
18	55928-600	RETAINING RING	1
19	55935-800-S02	RETAINING RING	1
20	55935-825	RETAINING RING	1
21	755-023	U-CUP SEAL	1
22	330-057	SHSS, 3/8-16 x 1/2 LG	2
23	321-314	HHCS, GRADE 8, 1/2-20 x 2.5 LG	4
24	331-002	SHSS, 3/8-16 x 1/2 LG	1
25	351-038	HEX NUT, 1/2-20, GRADE 8	4
26	362-005	FLAT WASHER, 1/2 SAE	8
27	363-004	SPLIT LOCKWASHER, 1/2	4
28	897010	SHIP ADAPTER	1
29	888221	SHIP ADAPTER (NOT SHOWN)	1
30	897025	SHIP ADAPTER (NOT SHOWN)	1

Parts List – Figure 3

When ordering replacement parts/kits, please specify model, serial number and color of your unit.

◆ PART OF REPAIR PARTS KIT

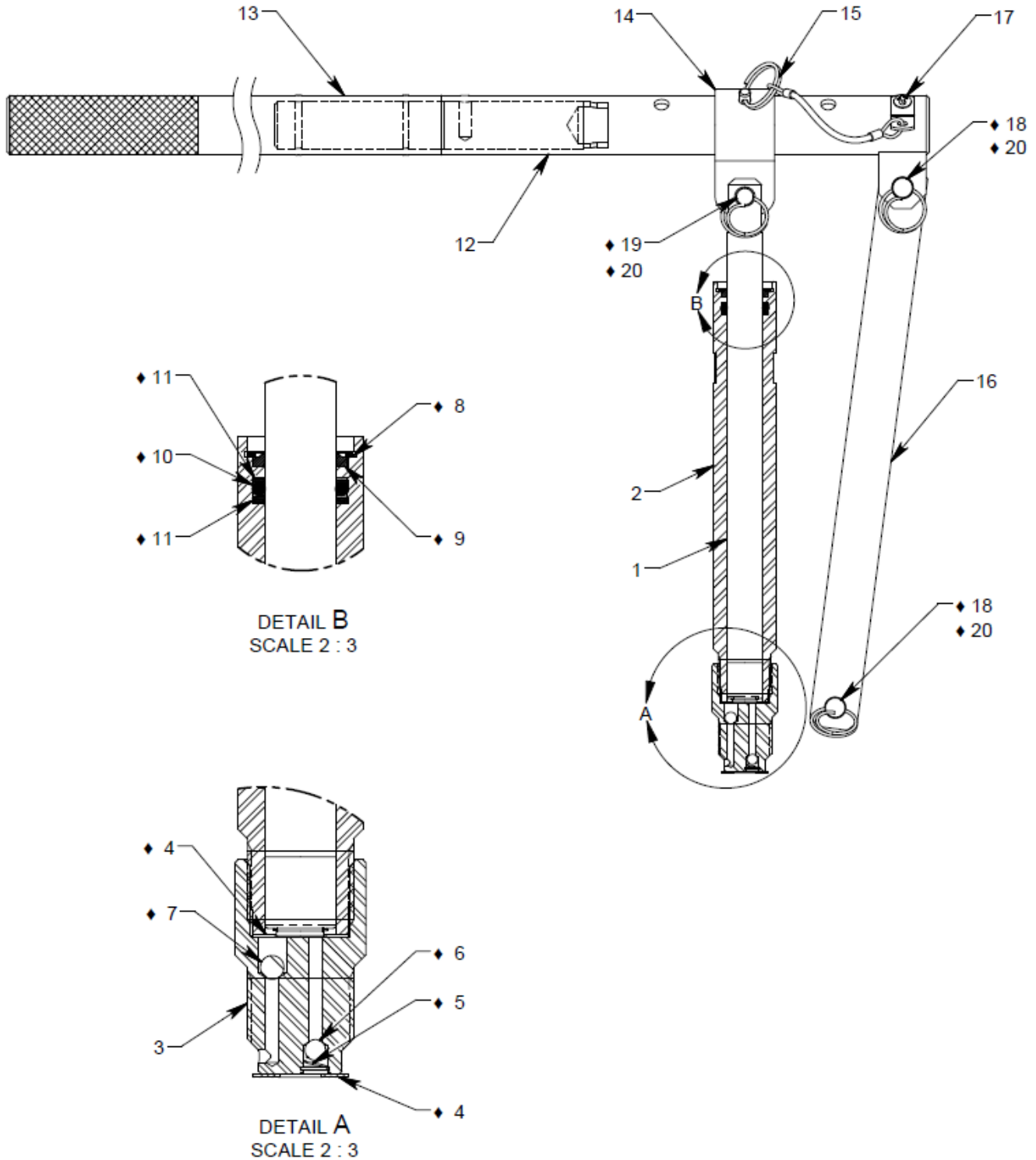

Parts List – Figure 3

When ordering replacement parts/kits, please specify model, serial number and color of your unit.

Item	Part Number	Description	Qty
	55320B	Hand Pump Assembly; consists of:	
1	55321	PISTON	1
2	55322	CYLINDER	1
3	55010	VALVE BLOCK	1
4	55024	GASKET	2
5	55295	SPRING	1
6	412-003	STEEL BALL, 7/32 DIA	1
7	412-004	STEEL BALL, 1/4 DIA	1
8	55926-112	RETAINING RING	1
9	55911-15	SCRAPER RING	1
10	55925-210	O-RING	1
11	55922-15	BACK-UP RING	2
12	55328	FULCRUM	1
13	55762-9	PUMP HANDLE	1
14	55333	PUMP HANDLE CLAMP	1
15	370-001	QUICK RELEASE PIN, 1/4 DIA	1
16	55327A	LINK	1
17	MS51861-44C	SELF TAPPING SCREW, #10	1
18	373-001	CLEVIS PIN, 7/16 DIA	2
19	373-002	CLEVIS PIN, 3/8 DIA	1
20	372-031	COTTER RING, 7/16 PIN DIA	3

Parts List – Figure 4

When ordering replacement parts/kits, please specify model, serial number and color of your unit.

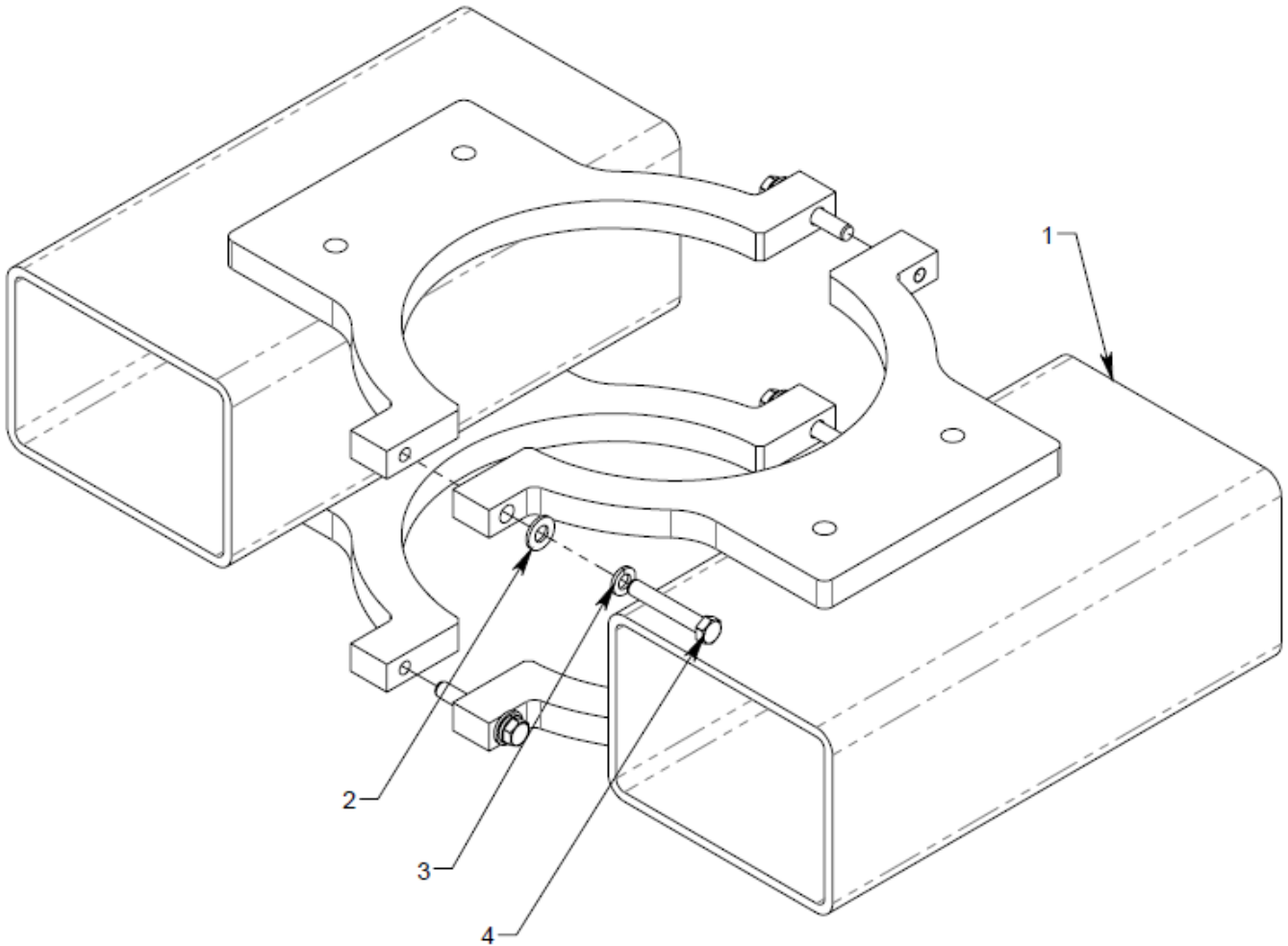

Item	Part Number	Description	Qty
	897071	Forklift Tube Assembly; consists of:	
1	897070	FORKLIFT TUBE HALF	2
2	361-001	FLAT WASHER, 3/8	4
3	363-003	SPLIT LOCKWASHER, 3/8	4
4	321-362	HHCS, 3/8-24 X 2-1/4" LG	4



APPENDIX I

Safety Data Sheet MIL-PRF-5606 Hydraulic Fluid

Product Name: MOBIL AERO HFA
Revision Date: 01 Oct 2015
Page 1 of 12

SAFETY DATA SHEET

SECTION 1 PRODUCT AND COMPANY IDENTIFICATION

PRODUCT

Product Name: MOBIL AERO HFA
Product Description: Base Oil and Additives
Product Code: 201550401020, 490110-00, 970584
Intended Use: Aviation hydraulic oil

COMPANY IDENTIFICATION

Supplier: EXXON MOBIL CORPORATION
22777 Springwoods Village Parkway
Spring, TX. 77253 USA

24 Hour Health Emergency 609-737-4411
Transportation Emergency Phone 800-424-9300 or 703-527-3887 CHEMTREC
Product Technical Information 800-662-4525
MSDS Internet Address <http://www.exxon.com>, <http://www.mobil.com>

SECTION 2 HAZARDS IDENTIFICATION

This material is hazardous according to regulatory guidelines (see (M)SDS Section 15).

CLASSIFICATION:

Flammable liquid: Category 4.
Aspiration toxicant: Category 1.

LABEL:

Pictogram:



Signal Word: Danger

Hazard Statements:

H227: Combustible liquid. H304: May be fatal if swallowed and enters airways.

Precautionary Statements:

P210: Keep away from flames and hot surfaces. -- No smoking. P273: Avoid release to the environment. P280: Wear protective gloves and eye / face protection. P301 + P310: IF SWALLOWED: Immediately call a POISON CENTER or doctor/physician. P331: Do NOT induce vomiting. P370 + P378: In case of fire: Use water fog, foam, dry chemical or carbon dioxide (CO2) to extinguish. P403 + P235: Store in a well-ventilated place. Keep cool. P405: Store locked up. P501: Dispose of contents and container in accordance with local regulations.

Product Name: MOBIL AERO HFA
 Revision Date: 01 Oct 2015
 Page 2 of 12

Other hazard information:

HAZARD NOT OTHERWISE CLASSIFIED (HNOC): None as defined under 29 CFR 1910.1200.

PHYSICAL / CHEMICAL HAZARDS

Material can accumulate static charges which may cause an ignition. Material can release vapors that readily form flammable mixtures. Vapor accumulation could flash and/or explode if ignited. Combustible.

HEALTH HAZARDS

High-pressure injection under skin may cause serious damage. Excessive exposure may result in eye, skin, or respiratory irritation.

ENVIRONMENTAL HAZARDS

No significant hazards.

NFPA Hazard ID:	Health: 1	Flammability: 2	Reactivity: 0
HMIS Hazard ID:	Health: 1*	Flammability: 2	Reactivity: 0

NOTE: This material should not be used for any other purpose than the intended use in Section 1 without expert advice. Health studies have shown that chemical exposure may cause potential human health risks which may vary from person to person.

SECTION 3	COMPOSITION / INFORMATION ON INGREDIENTS
------------------	---

This material is defined as a mixture.

Hazardous Substance(s) or Complex Substance(s) required for disclosure

Name	CAS#	Concentration*	GHS Hazard Codes
2,6-DI-TERT-BUTYL-P-CRESOL	128-37-0	0.1 - < 1%	H400(M factor 1), H410(M factor 1)
DISTILLATES (PETROLEUM), HYDROTREATED LIGHT	64742-47-8	5 - < 10%	H304
HYDROTREATED LIGHT NAPHTHENIC DISTILLATE (PETROLEUM)	64742-53-6	50 - < 70%	H227, H304
HYDROTREATED MIDDLE DISTILLATE (PETROLEUM)	64742-46-7	20 - < 30%	H304
TRIPHENYL PHOSPHATE	115-86-6	0.1 - < 0.25%	H400(M factor 1), H410(M factor 1)

* All concentrations are percent by weight unless material is a gas. Gas concentrations are in percent by volume.

As per paragraph (i) of 29 CFR 1910.1200, formulation is considered a trade secret and specific chemical identity and exact percentage (concentration) of composition may have been withheld. Specific chemical identity and exact percentage composition will be provided to health professionals, employees, or designated representatives in accordance with applicable provisions of paragraph (i).

SECTION 4	FIRST AID MEASURES
------------------	---------------------------

INHALATION

Remove from further exposure. For those providing assistance, avoid exposure to yourself or others. Use adequate respiratory protection. If respiratory irritation, dizziness, nausea, or unconsciousness occurs, seek immediate medical assistance. If breathing has stopped, assist ventilation with a mechanical device or use mouth-to-mouth resuscitation.

SKIN CONTACT

Wash contact areas with soap and water. Remove contaminated clothing. Launder contaminated clothing before reuse. If product is injected into or under the skin, or into any part of the body, regardless of the appearance of the wound or its size, the individual should be evaluated immediately by a physician as a surgical emergency. Even though initial symptoms from high pressure injection may be minimal or absent, early surgical treatment within the first few hours may significantly reduce the ultimate extent of injury.

EYE CONTACT

Flush thoroughly with water. If irritation occurs, get medical assistance.

INGESTION

Seek immediate medical attention. Do not induce vomiting.

NOTE TO PHYSICIAN

If ingested, material may be aspirated into the lungs and cause chemical pneumonitis. Treat appropriately.

SECTION 5 FIRE FIGHTING MEASURES

EXTINGUISHING MEDIA

Appropriate Extinguishing Media: Use water fog, foam, dry chemical or carbon dioxide (CO₂) to extinguish flames.

Inappropriate Extinguishing Media: Straight Streams of Water

FIRE FIGHTING

Fire Fighting Instructions: Evacuate area. Prevent runoff from fire control or dilution from entering streams, sewers, or drinking water supply. Firefighters should use standard protective equipment and in enclosed spaces, self-contained breathing apparatus (SCBA). Use water spray to cool fire exposed surfaces and to protect personnel.

Unusual Fire Hazards: Combustible. Pressurized mists may form a flammable mixture.

Hazardous Combustion Products: Aldehydes, Incomplete combustion products, Oxides of carbon, Phosphorus oxides, Smoke, Fume, Sulfur oxides

FLAMMABILITY PROPERTIES

Flash Point [Method]: >82°C (180°F) [ASTM D-93]

Flammable Limits (Approximate volume % in air): LEL: 0.7 UEL: 7.0 [Estimated]

Autoignition Temperature: >225°C (437°F)

SECTION 6 ACCIDENTAL RELEASE MEASURES

NOTIFICATION PROCEDURES

In the event of a spill or accidental release, notify relevant authorities in accordance with all applicable

regulations. US regulations require reporting releases of this material to the environment which exceed the applicable reportable quantity or oil spills which could reach any waterway including intermittent dry creeks. The National Response Center can be reached at (800)424-8802.

PROTECTIVE MEASURES

Avoid contact with spilled material. Warn or evacuate occupants in surrounding and downwind areas if required due to toxicity or flammability of the material. See Section 5 for fire fighting information. See the Hazard Identification Section for Significant Hazards. See Section 4 for First Aid Advice. See Section 8 for advice on the minimum requirements for personal protective equipment. Additional protective measures may be necessary, depending on the specific circumstances and/or the expert judgment of the emergency responders.

For emergency responders: Respiratory protection: respiratory protection will be necessary only in special cases, e.g., formation of mists. Half-face or full-face respirator with filter(s) for dust/organic vapor or Self Contained Breathing Apparatus (SCBA) can be used depending on the size of spill and potential level of exposure. If the exposure cannot be completely characterized or an oxygen deficient atmosphere is possible or anticipated, SCBA is recommended. Work gloves that are resistant to hydrocarbons are recommended. Gloves made of polyvinyl acetate (PVA) are not water-resistant and are not suitable for emergency use. Chemical goggles are recommended if splashes or contact with eyes is possible. Small spills: normal antistatic work clothes are usually adequate. Large spills: full body suit of chemical resistant, antistatic material is recommended.

SPILL MANAGEMENT

Land Spill: Eliminate all ignition sources (no smoking, flares, sparks or flames in immediate area). Stop leak if you can do it without risk. All equipment used when handling the product must be grounded. Do not touch or walk through spilled material. Prevent entry into waterways, sewer, basements or confined areas. A vapor suppressing foam may be used to reduce vapors. Use clean non-sparking tools to collect absorbed material. Absorb or cover with dry earth, sand or other non-combustible material and transfer to containers. Large Spills: Water spray may reduce vapor; but may not prevent ignition in closed spaces. Recover by pumping or with suitable absorbent.

Water Spill: Stop leak if you can do it without risk. Confine the spill immediately with booms. Warn other shipping. Remove from the surface by skimming or with suitable absorbents. Seek the advice of a specialist before using dispersants.

Water spill and land spill recommendations are based on the most likely spill scenario for this material; however, geographic conditions, wind, temperature, (and in the case of a water spill) wave and current direction and speed may greatly influence the appropriate action to be taken. For this reason, local experts should be consulted. Note: Local regulations may prescribe or limit action to be taken.

ENVIRONMENTAL PRECAUTIONS

Large Spills: Dike far ahead of liquid spill for later recovery and disposal. Prevent entry into waterways, sewers, basements or confined areas.

SECTION 7	HANDLING AND STORAGE
------------------	-----------------------------

HANDLING

Avoid contact with skin. Avoid prolonged breathing of mists and heated vapor. Prevent small spills and leakage to avoid slip hazard. Material can accumulate static charges which may cause an electrical spark (ignition source). When the material is handled in bulk, an electrical spark could ignite any flammable vapors from liquids or residues that may be present (e.g., during switch-loading operations). Use proper bonding and/or ground procedures. However, bonding and grounds may not eliminate the hazard from static

accumulation. Consult local applicable standards for guidance. Additional references include American Petroleum Institute 2003 (Protection Against Ignitions Arising out of Static, Lightning and Stray Currents) or National Fire Protection Agency 77 (Recommended Practice on Static Electricity) or CENELEC CLC/TR 50404 (Electrostatics - Code of practice for the avoidance of hazards due to static electricity).

Static Accumulator: This material is a static accumulator.

STORAGE

The container choice, for example storage vessel, may effect static accumulation and dissipation. Keep container closed. Handle containers with care. Open slowly in order to control possible pressure release. Store in a cool, well-ventilated area. Storage containers should be grounded and bonded. Fixed storage containers, transfer containers and associated equipment should be grounded and bonded to prevent accumulation of static charge.

SECTION 8 EXPOSURE CONTROLS / PERSONAL PROTECTION

EXPOSURE LIMIT VALUES

Exposure limits/standards (Note: Exposure limits are not additive)

Substance Name	Form	Limit / Standard		NOTE	Source
2,6-DI-TERT-BUTYL-P-CRESOL	Inhalable fraction and vapor	TWA	2 mg/m3	N/A	ACGIH
DISTILLATES (PETROLEUM), HYDROTREATED LIGHT [total hydrocarbon vapor]	Non-Aerosol	TWA	200 mg/m3	Skin	ACGIH
HYDROTREATED LIGHT NAPHTHENIC DISTILLATE (PETROLEUM)	Mist.	TWA	5 mg/m3	N/A	OSHA Z1
HYDROTREATED LIGHT NAPHTHENIC DISTILLATE (PETROLEUM)	Inhalable fraction.	TWA	5 mg/m3	N/A	ACGIH
HYDROTREATED LIGHT NAPHTHENIC DISTILLATE (PETROLEUM)	Mist.	TWA	5 mg/m3	N/A	ACGIH
HYDROTREATED MIDDLE DISTILLATE (PETROLEUM)	Mist.	TWA	5 mg/m3	N/A	OSHA Z1
HYDROTREATED MIDDLE DISTILLATE (PETROLEUM)	Inhalable fraction.	TWA	5 mg/m3	N/A	ACGIH
TRIPHENYL PHOSPHATE		TWA	3 mg/m3	N/A	OSHA Z1
TRIPHENYL PHOSPHATE		TWA	3 mg/m3	N/A	ACGIH

Exposure limits/standards for materials that can be formed when handling this product: When mists/aerosols can occur the following are recommended: 5 mg/m³ - ACGIH TLV (inhalable fraction), 5 mg/m³ - OSHA PEL.

NOTE: Limits/standards shown for guidance only. Follow applicable regulations.

No biological limits allocated.

ENGINEERING CONTROLS

The level of protection and types of controls necessary will vary depending upon potential exposure conditions.

Control measures to consider:

Use explosion-proof ventilation equipment to stay below exposure limits.

PERSONAL PROTECTION

Personal protective equipment selections vary based on potential exposure conditions such as applications, handling practices, concentration and ventilation. Information on the selection of protective equipment for use with this material, as provided below, is based upon intended, normal usage.

Respiratory Protection: If engineering controls do not maintain airborne contaminant concentrations at a level which is adequate to protect worker health, an approved respirator may be appropriate. Respirator selection, use, and maintenance must be in accordance with regulatory requirements, if applicable. Types of respirators to be considered for this material include:

No special requirements under ordinary conditions of use and with adequate ventilation.

For high airborne concentrations, use an approved supplied-air respirator, operated in positive pressure mode. Supplied air respirators with an escape bottle may be appropriate when oxygen levels are inadequate, gas/vapor warning properties are poor, or if air purifying filter capacity/rating may be exceeded.

Hand Protection: Any specific glove information provided is based on published literature and glove manufacturer data. Glove suitability and breakthrough time will differ depending on the specific use conditions. Contact the glove manufacturer for specific advice on glove selection and breakthrough times for your use conditions. Inspect and replace worn or damaged gloves. The types of gloves to be considered for this material include:

If prolonged or repeated contact is likely, chemical resistant gloves are recommended. If contact with forearms is likely, wear gauntlet style gloves.

Eye Protection: If contact is likely, safety glasses with side shields are recommended.

Skin and Body Protection: Any specific clothing information provided is based on published literature or manufacturer data. The types of clothing to be considered for this material include:

If prolonged or repeated contact is likely, chemical, and oil resistant clothing is recommended.

Specific Hygiene Measures: Always observe good personal hygiene measures, such as washing after handling the material and before eating, drinking, and/or smoking. Routinely wash work clothing and protective equipment to remove contaminants. Discard contaminated clothing and footwear that cannot be cleaned. Practice good housekeeping.

ENVIRONMENTAL CONTROLS

Comply with applicable environmental regulations limiting discharge to air, water and soil. Protect the environment by applying appropriate control measures to prevent or limit emissions.

SECTION 9

PHYSICAL AND CHEMICAL PROPERTIES

Note: Physical and chemical properties are provided for safety, health and environmental considerations only and may not fully represent product specifications. Contact the Supplier for additional information.

GENERAL INFORMATION

Physical State: Liquid

Color: Red

Product Name: MOBIL AERO HFA
 Revision Date: 01 Oct 2015
 Page 7 of 12

Odor: Characteristic
Odor Threshold: N/D

IMPORTANT HEALTH, SAFETY, AND ENVIRONMENTAL INFORMATION

Relative Density (at 15 °C): 0.88
Flammability (Solid, Gas): N/A
Flash Point [Method]: >82°C (180°F) [ASTM D-93]
Flammable Limits (Approximate volume % in air): LEL: 0.7 UEL: 7.0 [Estimated]
Autoignition Temperature: >225°C (437°F)
Boiling Point / Range: N/D
Decomposition Temperature: N/D
Vapor Density (Air = 1): N/D
Vapor Pressure: [N/D at 20 °C]
Evaporation Rate (n-butyl acetate = 1): N/D
pH: N/A
Log Pow (n-Octanol/Water Partition Coefficient): N/D
Solubility in Water: Negligible
Viscosity: 13.8 cSt (13.8 mm2/sec) at 40 °C | 5.1 cSt (5.1 mm2/sec) at 100°C [ASTM D 445]
Oxidizing Properties: See Hazards Identification Section.

OTHER INFORMATION

Freezing Point: N/D
Melting Point: N/A
Pour Point: -60°C (-76°F) [ASTM D97]
DMSO Extract (mineral oil only), IP-346: < 3 %wt

SECTION 10 STABILITY AND REACTIVITY

REACTIVITY: See sub-sections below.

STABILITY: Material is stable under normal conditions.

CONDITIONS TO AVOID: Open flames and high energy ignition sources.

MATERIALS TO AVOID: Strong oxidizers

HAZARDOUS DECOMPOSITION PRODUCTS: Material does not decompose at ambient temperatures.

POSSIBILITY OF HAZARDOUS REACTIONS: Hazardous polymerization will not occur.

SECTION 11 TOXICOLOGICAL INFORMATION

INFORMATION ON TOXICOLOGICAL EFFECTS

Hazard Class	Conclusion / Remarks
Inhalation	
Acute Toxicity: No end point data for material.	Minimally Toxic. Based on assessment of the components.
Irritation: No end point data for material.	Elevated temperatures or mechanical action may form vapors, mist, or fumes which may be irritating to the eyes, nose, throat, or lungs.

Product Name: MOBIL AERO HFA
 Revision Date: 01 Oct 2015
 Page 8 of 12

Ingestion	
Acute Toxicity: No end point data for material.	Minimally Toxic. Based on assessment of the components.
Skin	
Acute Toxicity: No end point data for material.	Minimally Toxic. Based on assessment of the components.
Skin Corrosion/Irritation: No end point data for material.	May dry the skin leading to discomfort and dermatitis. Based on assessment of the components.
Eye	
Serious Eye Damage/Irritation: No end point data for material.	May cause mild, short-lasting discomfort to eyes. Based on assessment of the components.
Sensitization	
Respiratory Sensitization: No end point data for material.	Not expected to be a respiratory sensitizer.
Skin Sensitization: No end point data for material.	Not expected to be a skin sensitizer. Based on assessment of the components.
Aspiration: Data available.	May be fatal if swallowed and enters airways. Based on physico-chemical properties of the material.
Germ Cell Mutagenicity: No end point data for material.	Not expected to be a germ cell mutagen. Based on assessment of the components.
Carcinogenicity: No end point data for material.	Not expected to cause cancer. Based on assessment of the components.
Reproductive Toxicity: No end point data for material.	Not expected to be a reproductive toxicant. Based on assessment of the components.
Lactation: No end point data for material.	Not expected to cause harm to breast-fed children.
Specific Target Organ Toxicity (STOT)	
Single Exposure: No end point data for material.	Not expected to cause organ damage from a single exposure.
Repeated Exposure: No end point data for material.	Not expected to cause organ damage from prolonged or repeated exposure. Based on assessment of the components.

TOXICITY FOR SUBSTANCES

NAME	ACUTE TOXICITY
2,6-DI-TERT-BUTYL-P-CRESOL	Oral Lethality: LD50 0.89 g/kg (Rat)

OTHER INFORMATION

For the product itself:

Repeated and/or prolonged exposure may cause irritation to the skin, eyes, or respiratory tract. Small amounts of liquid aspirated into the lungs during ingestion or from vomiting may cause chemical pneumonitis or pulmonary edema.

Contains:

Base oil severely refined: Not carcinogenic in animal studies. Representative material passes IP-346, Modified Ames test, and/or other screening tests. Dermal and inhalation studies showed minimal effects; lung non-specific infiltration of immune cells, oil deposition and minimal granuloma formation. Not sensitizing in test animals.

The following ingredients are cited on the lists below: None.

--REGULATORY LISTS SEARCHED--

Product Name: MOBIL AERO HFA
Revision Date: 01 Oct 2015
Page 9 of 12

1 = NTP CARC
2 = NTP SUS

3 = IARC 1
4 = IARC 2A

5 = IARC 2B
6 = OSHA CARC

SECTION 12 ECOLOGICAL INFORMATION

The information given is based on data available for the material, the components of the material, and similar materials.

ECOTOXICITY

Material -- Not expected to be harmful to aquatic organisms.

MOBILITY

More volatile component -- Highly volatile, will partition rapidly to air. Not expected to partition to sediment and wastewater solids.

Less volatile component -- Low solubility and floats and is expected to migrate from water to the land. Expected to partition to sediment and wastewater solids.

PERSISTENCE AND DEGRADABILITY

Biodegradation:

Components -- Expected to be inherently biodegradable

BIOACCUMULATION POTENTIAL

Majority of components -- Has the potential to bioaccumulate, however metabolism or physical properties may reduce the bioconcentration or limit bioavailability.

SECTION 13 DISPOSAL CONSIDERATIONS

Disposal recommendations based on material as supplied. Disposal must be in accordance with current applicable laws and regulations, and material characteristics at time of disposal.

DISPOSAL RECOMMENDATIONS

Product is suitable for burning in an enclosed controlled burner for fuel value or disposal by supervised incineration at very high temperatures to prevent formation of undesirable combustion products. Protect the environment. Dispose of used oil at designated sites. Minimize skin contact. Do not mix used oils with solvents, brake fluids or coolants.

REGULATORY DISPOSAL INFORMATION

RCRA Information: The unused product, in our opinion, is not specifically listed by the EPA as a hazardous waste (40 CFR, Part 261D), nor is it formulated to contain materials which are listed as hazardous wastes. It does not exhibit the hazardous characteristics of ignitability, corrosivity or reactivity and is not formulated with contaminants as determined by the Toxicity Characteristic Leaching Procedure (TCLP). However, used product may be regulated.

Empty Container Warning Empty Container Warning (where applicable): Empty containers may contain residue and can be dangerous. Do not attempt to refill or clean containers without proper instructions. Empty drums should be

Product Name: MOBIL AERO HFA
Revision Date: 01 Oct 2015
Page 10 of 12

completely drained and safely stored until appropriately reconditioned or disposed. Empty containers should be taken for recycling, recovery, or disposal through suitably qualified or licensed contractor and in accordance with governmental regulations. DO NOT PRESSURISE, CUT, WELD, BRAZE, SOLDER, DRILL, GRIND, OR EXPOSE SUCH CONTAINERS TO HEAT, FLAME, SPARKS, STATIC ELECTRICITY, OR OTHER SOURCES OF IGNITION. THEY MAY EXPLODE AND CAUSE INJURY OR DEATH.

SECTION 14 TRANSPORT INFORMATION

LAND (DOT)

Proper Shipping Name: COMBUSTIBLE LIQUID, N.O.S. (Distillates (Petroleum), Hydrotreated Light)
Hazard Class & Division: COMBUSTIBLE LIQUID
ID Number: NA1993
Packing Group: III
ERG Number: 128
Label(s): NONE
Transport Document Name: NA1993, COMBUSTIBLE LIQUID, N.O.S. (Distillates (Petroleum), Hydrotreated Light), COMBUSTIBLE LIQUID, PG III

Footnote: This material is not regulated under 49 CFR in a container of 119 gallon capacity or less when transported solely by land, as long as the material is not a hazardous waste, a marine pollutant, or specifically listed as a hazardous substance.

LAND (TDG): Not Regulated for Land Transport

SEA (IMDG): Not Regulated for Sea Transport according to IMDG-Code

Marine Pollutant: No

AIR (IATA): Not Regulated for Air Transport

SECTION 15 REGULATORY INFORMATION

OSHA HAZARD COMMUNICATION STANDARD: This material is considered hazardous in accordance with OSHA HazCom 2012, 29 CFR 1910.1200.

Listed or exempt from listing/notification on the following chemical inventories: AICS, DSL, ENCS, IECSC, KECI, PICCS, TCSI, TSCA

EPCRA SECTION 302: This material contains no extremely hazardous substances.

SARA (311/312) REPORTABLE HAZARD CATEGORIES: Fire. Immediate Health. Delayed Health.

SARA (313) TOXIC RELEASE INVENTORY: This material contains no chemicals subject to the supplier notification requirements of the SARA 313 Toxic Release Program.

Product Name: MOBIL AERO HFA
 Revision Date: 01 Oct 2015
 Page 11 of 12

The following ingredients are cited on the lists below:

Chemical Name	CAS Number	List Citations
DISTILLATES (PETROLEUM), HYDROTREATED LIGHT	64742-47-8	1, 17, 18
HYDROTREATED LIGHT NAPHTHENIC DISTILLATE (PETROLEUM)	64742-53-6	1, 4, 13, 17, 18
HYDROTREATED MIDDLE DISTILLATE (PETROLEUM)	64742-46-7	1, 4, 17, 18

--REGULATORY LISTS SEARCHED--

1 = ACGIH ALL	6 = TSCA 5a2	11 = CA P65 REPRO	16 = MN RTK
2 = ACGIH A1	7 = TSCA 5e	12 = CA RTK	17 = NJ RTK
3 = ACGIH A2	8 = TSCA 6	13 = IL RTK	18 = PA RTK
4 = OSHA Z	9 = TSCA 12b	14 = LA RTK	19 = RI RTK
5 = TSCA 4	10 = CA P65 CARC	15 = MI 293	

Code key: CARC=Carcinogen; REPRO=Reproductive

SECTION 16	OTHER INFORMATION
-------------------	--------------------------

N/D = Not determined, N/A = Not applicable

KEY TO THE H-CODES CONTAINED IN SECTION 3 OF THIS DOCUMENT (for information only):

- H227: Combustible liquid; Flammable Liquid, Cat 4
- H304: May be fatal if swallowed and enters airways; Aspiration, Cat 1
- H400: Very toxic to aquatic life; Acute Env Tox, Cat 1
- H410: Very toxic to aquatic life with long lasting effects; Chronic Env Tox, Cat 1

THIS SAFETY DATA SHEET CONTAINS THE FOLLOWING REVISIONS:

Revision Changes:

- Section 01: Company Mailing Address information was modified.
- Section 05: Hazardous Combustion Products information was modified.
- Section 15: List Citations Table information was modified.
- Section 15: National Chemical Inventory Listing information was modified.
- Section 14: Marine Pollutant information was modified.
- Composition: Component Table information was modified.
- Section 08: Exposure Limits Table information was modified.
- Section 16: Revision Information - Implementation of GHS requirements phrase. information was deleted.

The information and recommendations contained herein are, to the best of ExxonMobil's knowledge and belief, accurate and reliable as of the date issued. You can contact ExxonMobil to insure that this document is the most current available from ExxonMobil. The information and recommendations are offered for the user's consideration and examination. It is the user's responsibility to satisfy itself that the product is suitable for the intended use. If buyer repackages this product, it is the user's responsibility to insure proper health, safety and other necessary information is included with and/or on the container. Appropriate warnings and safe-handling procedures should be provided to handlers and users. Alteration of this document is strictly prohibited. Except to the extent required by law,



Product Name: MOBIL AERO HFA
Revision Date: 01 Oct 2015
Page 12 of 12

re-publication or retransmission of this document, in whole or in part, is not permitted. The term, "ExxonMobil" is used for convenience, and may include any one or more of ExxonMobil Chemical Company, Exxon Mobil Corporation, or any affiliates in which they directly or indirectly hold any interest.

Internal Use Only

MHC: 2A, 0, 0, 0, 1, 1

PPEC: C

DGN: 2005454XUS (552975)

Copyright 2002 Exxon Mobil Corporation, All rights reserved