

Model: 8920
Two Stage Fly-Away
Hydraulic Aviation Floating
Air-Retract Axle Jack

05/2026 – Rev. 02

For Spare Parts, Operations & Service Manuals or Service Needs
Scan the QR code or visit tronair.com/pages/tronair-information-center



The Tronair Group of Companies: Tronair | Columbus Jack | Eagle | Malabar International

Tronair, Inc.
1 Air Cargo Pkwy East
Swanton, OH 43558

Phone: (419) 866-6301 | 800-426-6301
Web: www.tronair.com
Email: sales@tronair.com

REVISION	DATE	TEXT AFFECTED
01	12/2018	Original release
02	05/2026	Modified 8.2 Special Tools, 8.3 Recommended Spare Parts List, and Parts List – Figure 3

TABLE OF CONTENTS

PAGE

1.0	PRODUCT INFORMATION	1
1.1	DESCRIPTION.....	1
1.2	MODEL & SERIAL NUMBER.....	1
1.3	MANUFACTURER.....	1
1.4	SPECIFICATIONS	1
1.5	PROTECTIVE DEVICES	1
2.0	SAFETY INFORMATION.....	2
2.1	USAGE AND SAFETY INFORMATION	2
3.0	PREPARATION PRIOR TO FIRST USE	2
4.0	TRAINING.....	2
4.1	TRAINING REQUIREMENTS	2
4.2	TRAINING PROGRAM	2
4.3	OPERATOR TRAINING.....	2
5.0	OPERATION.....	3
5.1	PRE OPERATION INSPECTION.....	3
5.2	OPERATING PROCEDURES.....	3
6.0	TROUBLE SHOOTING	4
7.0	MAINTENANCE.....	5
7.1	SERVICING	5
7.2	DISASSEMBLY INSPECTION.....	5
7.3	OVERHAUL INSTRUCTIONS.....	5
7.4	SPECIAL INSTALLATIONS	6
7.5	TESTING	7
8.0	PROVISION OF SPARES.....	7
8.1	SOURCE OF SPARE PARTS.....	7
8.2	SPECIAL TOOLS.....	7
8.3	RECOMMENDED SPARE PARTS LISTS	8
9.0	IN SERVICE SUPPORT.....	9
10.0	GUARANTEES/LIMITATION OF LIABILITY.....	9
11.0	APPENDICES	9

This product can not be modified without the written approval of Tronair, Inc. Any modifications done without written approval voids all warranties and releases Tronair, Inc., its suppliers, distributors, employees, or financial institutions from any liability from consequences that may occur. Only Tronair OEM replacement parts shall be used.



CAUTION!

Aircraft manufacturer's specifications and instructions must be followed. In the event of contradiction between aircraft manufacturer's specifications and Malabar's, aircraft manufacturer's will prevail.

1.0 PRODUCT INFORMATION

1.1 DESCRIPTION

The Malabar Fly-Away Floating Air-Retract Axle Jack Model 8920 is a 95 ton capacity two stage telescoping hydraulic jack designed primarily for use in jacking the main and/or nose landing gear of various aircraft. Simple and easy single valve control for aircraft raising and lowering. The jack consists of a two stage cylinder assembly mounted on a spherical bearing (this bearing allows the jack ship adapter to follow the arc of the aircraft jack point, thus greatly reducing the stress on the jack's cylinder assembly as well as the aircraft axle and strut), base assembly, frame/reservoir assembly, valve block assembly, hand pump assembly, air-retract, and control console. Leaf centering springs retain cylinder assembly in the center position while under no load. The jack can be wheeled by one or two persons by placing hand pump handles in handle holders and inserting quick release pins. Lifting handles are also supplied for ease of lifting the jack by four people.

1.2 MODEL & SERIAL NUMBER

Reference nameplate on unit

1.3 MANUFACTURER

TRONAIR, Inc./Malabar International
1 Air Cargo Pkwy East
Swanton, Ohio 43558 USA

Telephone: (419) 866-6301 or 800-426-6301
Fax: (419) 867-0634
E-mail: sales@tronair.com
Website: www.tronair.com

1.4 SPECIFICATIONS

Rated Capacity	95 tons (86.2m. tons)
Low Height	10.5 in (267 mm)
Hydraulic Lift.....	10.88 in (276 mm)
Extension Screw	4.62 in (117 mm)
Total Extended Height	26 in (660 mm)
Oil Pressure at Rated Capacity	8000 psig (562.5 kg/sq cm)
Safety Pop-off Valve set at	100.7 ton (91.4 m. tons)
Proof Load.....	118 ton (107 m. tons)
Floor Loading at Rated Capacity	1020 psi (71.7 kg/sq cm)
Reservoir Capacity	2 gal (7.5 l)
Hydraulic Fluid.....	MIL-PRF-5606 or equivalent
Approximate Jack Net Weight	315 lbs (143 kg)
Total Handle Load (Wheeling).....	75 lbs (34 kg)

1.5 PROTECTIVE DEVICES

- A safety pop-off valve is incorporated in the jack (located in the valve block) to prevent lifting of loads in excess of 100.7 tons (91.4 m. tons).
- A velocity fuse is incorporated in the jack to prevent rapid retraction of the plungers in the event of hydraulic line rupture.
- The extension screw has a positive stop to prevent it from being extended beyond its safe thread engagement.
- Air relief valve is incorporated in the jack (located next to the air valve) to prevent over pressurizing the pneumatic system.

2.0 SAFETY INFORMATION

2.1 USAGE AND SAFETY INFORMATION

To ensure safe operations please read the following statements and understand their meaning. Also refer to your equipment manufacturer's manual for other important safety information. This manual contains safety precautions which are explained below. Please read carefully.



WARNING!

Warning is used to indicate the presence of a hazard that can cause **severe personal injury, death, and/or substantial property damage** if the Warning Notice is ignored.



CAUTION!

Caution is used to indicate the presence of a hazard, which will or can cause **minor personal injury or property damage** if the Caution Notice is ignored.

3.0 PREPARATION PRIOR TO FIRST USE

1. The jack is shipped without hydraulic fluid in the reservoir. Do not operate air or hand pumps until reservoir is filled with hydraulic fluid MIL-PRF-5606 or approved equivalent. Remove filler cap and fill reservoir to mark on dipstick (reservoir capacity is approximately 2 gallons/7.5 liters). Plungers must be fully retracted before filling reservoir. Replace filler cap.
2. Open release valve and operate hand pumps a few strokes to bleed all air trapped under hand pumps.
3. Close release valve and operate hand pump to raise plungers approximately 1 inch.
4. Open release valve to retract plungers fully to bleed all air trapped under jack plungers. Close release valve.

4.0 TRAINING

4.1 TRAINING REQUIREMENTS

The employer of the operator is responsible for providing a training program sufficient for the safe operation of the unit.

4.2 TRAINING PROGRAM

The employer provided operator training program should cover safety procedures concerning use of the unit in and around the intended aircraft at the intended aircraft servicing location.

4.3 OPERATOR TRAINING

The operator training should provide the required training for safe operation of the unit.

NOTE: Maintenance and Trouble Shooting are to be performed by a skilled and trained technician.

5.0 OPERATION

5.1 PRE OPERATION INSPECTION

Each time the jack is to be used, inspect the following:

1. Check jack structure for rigidity. Make sure all bolts are tightened.
2. Check hydraulic line connections for leaks. Tighten as required.
3. Check for hydraulic fluid leaks around the cylinder assembly, reservoir, air pump and hand pumps.
4. Check hand pumps for proper operation.
5. Check caster wheels for proper operation.
6. Check reservoir fluid level with jack plungers fully retracted.

5.2 OPERATING PROCEDURES

1. Position the jack on a level surface under the jacking pad of the aircraft axle.



CAUTION!

Do not extend extension screw against aircraft jack pad with the plungers fully retracted.

2. Raise the extension screw by turning counterclockwise until the ship adapter is 1/2" to 1" from aircraft axle jacking pad or as far as the screw will travel (4.62 inches maximum).
3. Close the release valve located on control console.



CAUTION!

Air relief valve must be installed at all times. If air relief valve is removed, it is possible to over pressurize the pneumatic system which could cause equipment failure and possible bodily injury.

4. Connect air supply (90-110 psig) to the 1/4 NPT air inlet at the air valve on the control console (a minimum of 56 scfm is required). Air relief valve must be properly installed. Do not attempt to remove air relief valve.
5. The jack is equipped with two hand pumps. One with 3/4 inch diameter pump plunger for rapid raising of jack plungers under low pressure and one with 7/16 inch diameter pump plunger for high pressure operation. The hand pumps can be operated by placing pump handle over the end of the pump fulcrum and operating either the low or high pressure hand pump.
6. Operate air valve or either hand pump to raise plungers until the ship adapter contacts the jacking pad.
7. Insure ship adapter and jacking pad are correctly mated.
8. To raise the load:
 - a. Operate the air valve or either hand pump as required.
 - b. Do not lift a load greater than the rated capacity of 95 tons (86.2 m. tons).
9. To lower the load:
 - a. Slowly open the release valve to lower the load. The speed of lowering is controlled by the amount at which the release valve is open.

Note: It is important to lower the load slowly. Retracting the plungers too fast will cause the velocity fuse to close and prevent plungers from retracting. Should this occur, close release valve, operate either pump to reset velocity fuse and then open release valve again slowly. Plungers will retract fully, automatically.

10. Lower the extension. Close release valve.
11. Cover jack when not in use to prevent entrance of contaminants and water into the cylinder.

6.0 TROUBLE SHOOTING

TROUBLE	PROBABLE CAUSE	REMEDY
Jack will not raise	Release valve open (Oil passing back into reservoir)	Close valve firmly
	Intake valve open. (Oil passing back into reservoir)	Pump rapidly to flush dirt off
	Discharge valve open (Oil passing back into pump chamber)	Pump rapidly to flush dirt off
	Sticking intake valve	Remove pump from jack base. Unscrew valve block. Clean or replace valve
	Clogged screen	Remove and clean
	Lack of oil. Air under plunger	Refill. Check for leaks. Bleed air out by opening release valve. Pump rapidly a few times and close release valve
Jack will not raise to full height	Lack of oil	Refill, check for leaks
	Sticking intake valve	Remove pump from jack base. Unscrew valve block. Clean or replace ball valves. Re-tighten or repair
Jack will not raise capacity load	High pressure leaks (At pump or release valve)	Reseat valve
	Leaky release valve	Reseat valve and clean valve block
Jack raises and falls during each stroke	Leaky discharge valve	Tighten or replace ball valve or packing
Jack will not hold up load	Leaky release valve	Reseat valve
	Defective "O" ring and back up ring	Remove plunger and replace "O" ring and back up ring
Jack will not lower the load	Damaged release valve	Remove and replace parts as needed
	Bent plunger	Replace
Jack will not close completely	Air under plunger	Bleed air out. Open release valve and pump rapidly several times. Close valve
Handle stroke only partly effective	Air in pump chamber	Open release valve and pump rapidly several times. Close valve
	Sticking intake valve	Remove pump and clean valve block
	Clogged screen	Remove and clean
Handle raises without effort	Leaky intake valve	Remove pump and clean valve block
Handle snaps back	Sticking intake valve	Open release valve. Pump rapidly several times. Close valve
	Clogged screen	Remove and clean

7.0 MAINTENANCE

7.1 SERVICING

Servicing the jack consists primarily of the following:

1. When in use, the reservoir should be kept at the proper level with hydraulic fluid MIL-PRF-5606 or approved equivalent. Always check fluid level with jack plungers fully retracted.
2. Grease all wheels.
3. Lubricate hand pump pivot pins.
4. If jack has been put into storage or has not been used, the plungers must be fully extended and retracted every 90 days to exercise the seals. A portion of the lift should be operated by the air pump (if so equipped) and a portion by the hand pumps.

7.2 DISASSEMBLY INSPECTION



CAUTION!

The safety pop-off valve, located in the valve block, should not be removed unless absolutely necessary. The valve is set to by-pass hydraulic fluid back to the reservoir at 4-6% above the rated capacity of 95 tons. If adjustment is required, see procedure in 7.5 Testing.

When necessary to disassemble the jack, drain all hydraulic fluid from reservoir through plug at reservoir bottom and carefully inspect the following:

1. Inspect interior walls of jack cylinder and hand pump cylinders for smoothness and freedom from rust, nicks, scratches and excessive wear.
2. Inspect exterior walls of jack plungers for smoothness and freedom from rust, pits and excessive wear.
3. Check extension screw, cylinder, etc., for corrosion, wear and condition of threads.
4. Verify the extension screw has a positive stop to prevent it from being extended beyond its safe thread engagement.
5. Inspect seals, gaskets and wipers in the cylinder assembly and hand pumps for cuts, wear, dirt, scratches, deterioration and distortion.
6. Stop rings for excessive scoring and/or wear.
7. Check oil screen by removing valve block and verifying cleanliness.
8. Inspect valves and valve seats in the valve block for scratches, dents and proper seating of the balls.
9. Inspect all pivot pins for wear, cracks, pits or evidence of damage or pending damage.
10. Inspect all areas for excessive dirt, oil, dust and chips.

7.3 OVERHAUL INSTRUCTIONS

No definite time schedule can be established for the overhaul of the jack for replacement of the various moving parts. The number of times the jack is raised and lowered and the amount of load raised at each operation materially affect the life of the working parts. Do not overload the jack. Overloading is dangerous, will hasten the need for overhaul and may damage the jack. During overhaul, replace all parts that do not pass disassembly inspection requirements. Regardless of apparent condition, replace all parts marked with (♦) in the parts breakdown. A repair parts kit (P/N 8920PK) which contains all of the parts marked with (♦) is available and recommended to keep on hand at your facility.

1. To disassemble cylinder assembly:
 - a. Open release valve located on control console.
 - b. Remove outer stop ring using spanner wrench (P/N 880481).
 - c. The inner plunger, outer plunger, and extension screw may now be carefully removed as a unit using extension screw lifting tool (P/N 880482). Do not cut or damage any of the seals.
 - d. Remove inner stop ring using spanner wrench (P/N 880480).
 - e. Remove inner plunger and extension screw from outer plunger carefully. Do not cut or damage any of the seals.
 - f. Remove inner plunger diaphragm retaining ring and diaphragm from bottom of inner plunger.
 - g. Remove extension screw roll pins and screw extension screw down through inner plunger.
2. Should it be necessary to remove cylinder from base, proceed as follows:
 - a. Remove hydraulic hose from top portion of cylinder.
 - b. Remove hydraulic hose, velocity fuse and nipple from lower portion of cylinder.
 - c. Remove cap screws, lockwashers and bars from the top of the base (4 places).
 - d. Remove cap screws, lockwashers and centering springs from the side of the base (4 places).
 - e. Cylinder may now be removed from the base.
 - f. Remove cylinder diaphragm from cylinder using spanner wrench (P/N 86305T).
 - g. Do not loosen or remove the two setscrews and jam nuts at the side of the base.

7.3 OVERHAUL INSTRUCTIONS (*continued*)



CAUTION!

When reassembling cylinder assembly (see figure 3), ensure cylinder (p/n 880408), outer plunger (p/n 885504), inner plunger (p/n 885506), cylinder diaphragm (p/n 880420), inner plunger diaphragm (p/n 880415) and extension screw (p/n 880418) all have an 'H' stamp on the bottom (for high heat treat). If no 'H' is stamped on bottom of these parts, do not reassemble, contact Malabar for further instruction.

3. Replace all worn or damaged seals. No special tools are required. If replacement of diaphragm seal (P/N 880417) is necessary, follow the installation diagram on sheet 5. Lubricate all seals and cylinder walls with hydraulic fluid MIL-H-5606 or approved equivalent.
4. When necessary to disassemble the jack:
 - a. Replace all defective parts.
 - b. Clean all metal parts with clean solvent and dry with compressed air.
 - c. Lubricate all threads. Use Teflon tape carefully on all pipe threads. Remove excess tape because it can clog valves and passages.
 - d. If ball valves, located in valve block, do not seat properly, they may be reseated by tapping the ball into the valve seat with a brass rod cupped at one end.
 - e. Should any malfunction occur in the velocity fuse, return to factory for repair or replacement.

7.4 SPECIAL INSTALLATIONS

Procedure to install new diaphragm seal:

1. Clean diaphragm with clean solvent and dry with compressed air. All parts and your hands should be clean for the next operation.
2. The diaphragm seal is to be installed firmly and quickly as explained in the installation diagram. Oily parts or hands will make the job more difficult.



CAUTION!

This is a Teflon jacketed seal with a thin stainless steel energizer spring. Handle carefully so you do not damage the seal lips, jacket and/or spring. The seal must be installed as shown below. Remember that the lips of the seal are towards the pressure. Recheck before proceeding

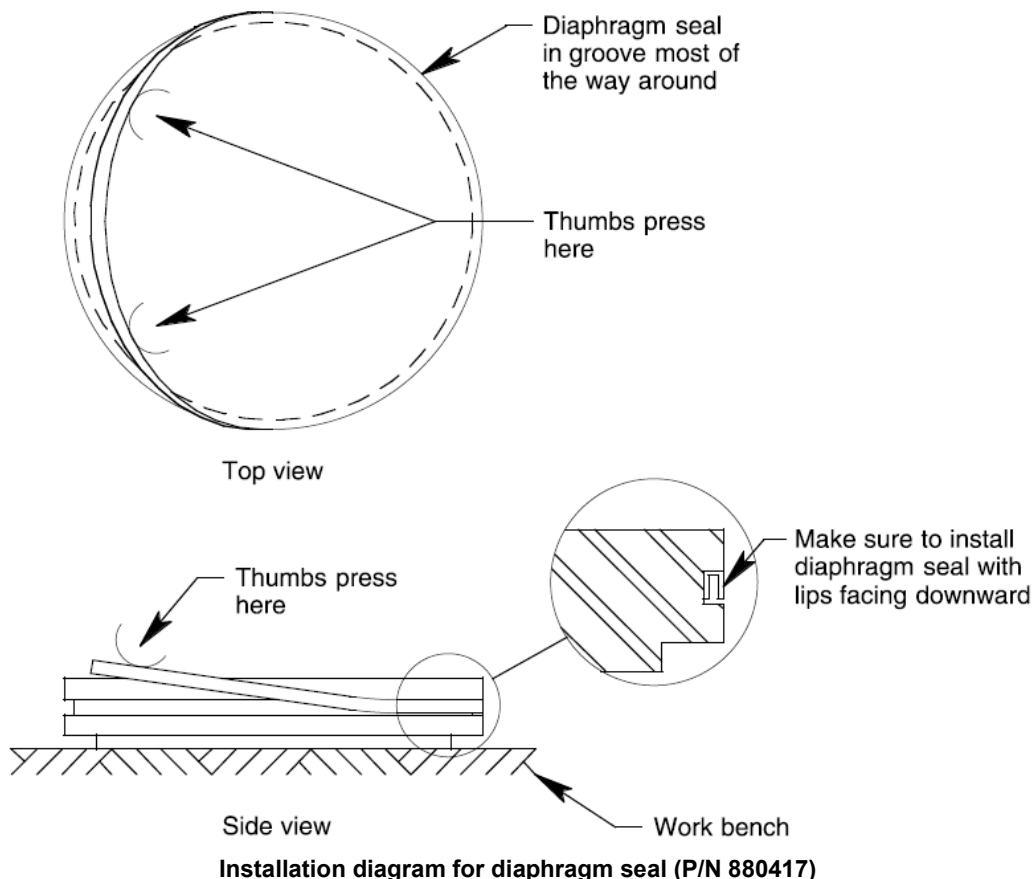

7.5 TESTING

Place jack in a load indicating test fixture. Make sure the test adapter is 3/4 inch male spherical radius. Operate hand pump to extend two outer plungers fully and inner plunger partially. Make sure the extension screw and the test adapter are correctly mated. Load test the jack at rated capacity of 45 tons. If the jack fails to operate properly, check for trouble as indicated in

6.0 Trouble Shooting. With the plungers extended and supporting the capacity load, allow the jack to stand for 10 minutes. Any excess settling indicates leakage in the hand pumps, check valves or jack packing seals. Check for hydraulic fluid leaks and replace all defective parts.

If adjustment is required for the safety pop-off valve, perform the following procedure:

1. Cut, remove and discard lead & wire seal (figure 4, item 35).
2. Remove plug (figure 4, item 32). Close release valve (figure 1, item 8).
3. Place jack in a load indicating test fixture. Make sure the test adapter is 3/4 inch male spherical radius. Operate hand pump to extend plungers against the test adapter. Make sure ship adapter and test adapter are correctly mated.
4. While operating the hand pump, adjust set screw (figure 4, item 30) until the safety pop-off valve bypasses hydraulic fluid back to the reservoir at 98.8 to 100.7 tons.
5. Replace plug (figure 4, item 32). Once more operate hand pump to verify correct setting.
6. Install new lead & wire seal (figure 4, item 35)..
7. Open release valve to relieve pressure.

8.0 PROVISION OF SPARES

8.1 SOURCE OF SPARE PARTS

Spare parts may be obtained from the manufacturer:

TRONAIR, Inc.	Telephone: (419) 866-6301 or 800-426-6301
1 Air Cargo Pkwy East	Fax: (419) 867-0634
Swanton, Ohio 43558 USA	E-mail: sales@tronair.com
	Website: www.tronair.com



For Spare Parts, Operations & Service Manuals or Service Needs:
Scan the QR code or visit tronair.com/pages/tronair-information-center

8.2 SPECIAL TOOLS

The following tools are necessary to disassemble/reassemble the cylinder assembly. These tools may be purchased upon request

Part Number	Description	Qty
880480	Spanner wrench, inner stop ring	1
880481	Spanner wrench, outer stop ring	1
880482	Lifting tool, extension screw	1

8.3 RECOMMENDED SPARE PARTS LISTS

The following spare parts are recommended and available upon request. Reference the following page(s) for Replacement Parts and Kits available.

Part Number	Description	Qty
K-5959	REPAIR PARTS KIT	1
492-119	WHEEL	2
892007	WHEEL AXLE	1
892035	VALVE BLOCK AND HAND PUMP ASSEMBLY	1
55001	FULCRUM	2
886659	PLUNGER, 7/16 DIA	1
886658	BODY, 7/16 DIA	1
886657	PLUNGER, 13/16 DIA	1
886656	BODY, 13/16 DIA	1
892003	PUMP HANDLE	1
892012	HYDRAULIC HOSE	1
86564	DIPSTICK	1
85416	RELEASE VALVE	1
424-060	DRAIN COCK VALVE	1
86320A	SHIP ADAPTER	1
TR-2925	INNER STOP RING	1
TR-2924	OUTER STOP RING	1
86323	CENTERING SPRING SET	2
86328	VELOCITY FUSE	1
86321	BASE PAD	1
559289-14	PLACARD, TONNAGE, 95 TON	1
86562	PLACARD, INSTRUCTION	1
55997-2	NAME PLATE	1
55998-1	STICKER, MALABAR	2
55994	STICKER, FLUID	1
441-018	AIR PUMP	1
441-037	AIR DRIVE SEAL KIT, AIR PUMP	1
441-092	HYDRAULIC SEAL KIT, AIR PUMP	1
421-006	AIR VALVE	1
425-001	AIR RELIEF VALVE	1
55568	OIL SCREEN	1

9.0 IN SERVICE SUPPORT

Contact Malabar, Inc. for technical services and information. See Section 1.3 – Manufacturer.

10.0 GUARANTEES/LIMITATION OF LIABILITY

- I. Seller warrants each new product of its manufacture to be free from defects in material or workmanship, under proper, reasonable, and normal use and service.
- II. The warranty period shall be as follows:
 - A. For Malabar equipment, with the exception of Tripod Jacks, the warranty period is one (1) year after date of shipment.
 - B. For Malabar Tripod Jacks, the warranty period is three (3) years after date of shipment.
- III. Where Buyer claims an alleged defect in material or workmanship and so advises Seller in writing within ten (10) days after discovery thereof, then and in such event, Buyer shall return said equipment, transportation prepaid, to the Seller, provided such return is timely and within the above-mentioned warranty period. This warranty and liability of the Seller is expressly limited solely to replacement or repair of defective parts or goods, and return at Buyer's expense to Buyer after finding by Seller the product was defective prior to original shipment or, at the option of Seller, to providing refund to Buyer of the purchase price for said product.
- IV. It is further expressly understood and agreed that:
 - A. THERE IS NO WARRANTY, REPRESENTATION OF CONDITION OF ANY KIND, EXPRESS OR IMPLIED, (INCLUDING NO WARRANTY OF MERCHANTABILITY OR OF FITNESS) EXCEPT THAT THE MATERIAL SHALL BE OF THE QUALITY SPECIFIED IN APPLICABLE SPECIFICATIONS, AND NONE SHALL BE IMPLIED BY LAW. Except as otherwise provided herein, quality shall be in accordance with Seller's specifications. Final determination of the material for the use contemplated by Buyer is the sole responsibility of Buyer and Seller shall have no responsibility in connection with such suitability, and
 - B. Buyer's sole and exclusive remedy shall be repair or replacement of defective parts or goods by the Seller. Should the goods, in the judgment of Seller, preclude the remedying of the warranted defects by repair or replacement, the Buyer's sole and exclusive remedy shall be the refund of the purchase price, and
 - C. Seller shall not be liable for prospective profits or special, indirect or consequential damages, nor shall any recovery of any kind against Seller be greater in amount than the purchase price of the specific material sold and causing the alleged loss, damage or injury. Buyer assumes all risk and liability for loss, damage or injury to persons or property of Buyer or others arising out of use or possession of any product or part sold hereunder, and
 - D. Seller shall in no way be deemed or held to be obligated, liable or accountable upon or for any guarantees or warranties, express or implied, or created by statute or by operation of law or otherwise, in any manner of form beyond its express agreement above set forth, and
 - E. No warranty herein shall apply to any product which shall have been repaired or altered, unless such alteration or repair has been made by Seller or if, after return to and inspection by Seller, the product is found by Seller to have been subject to misuse, negligence or accident, and
 - F. No warranty of any nature is made by Seller as to any component forming a part of the product sold and Buyer shall receive only such warranties offered by such other manufacturer of such component, and
 - G. Seller does not assume nor does Seller authorize any other person to assume for it any other liability or make any warranty in connection with the sale of its products.

11.0 APPENDICES

APPENDIX I Safety Data Sheet – MIL-PRF-5606 Hydraulic Fluid

Pneumatic/Hydraulic Diagram

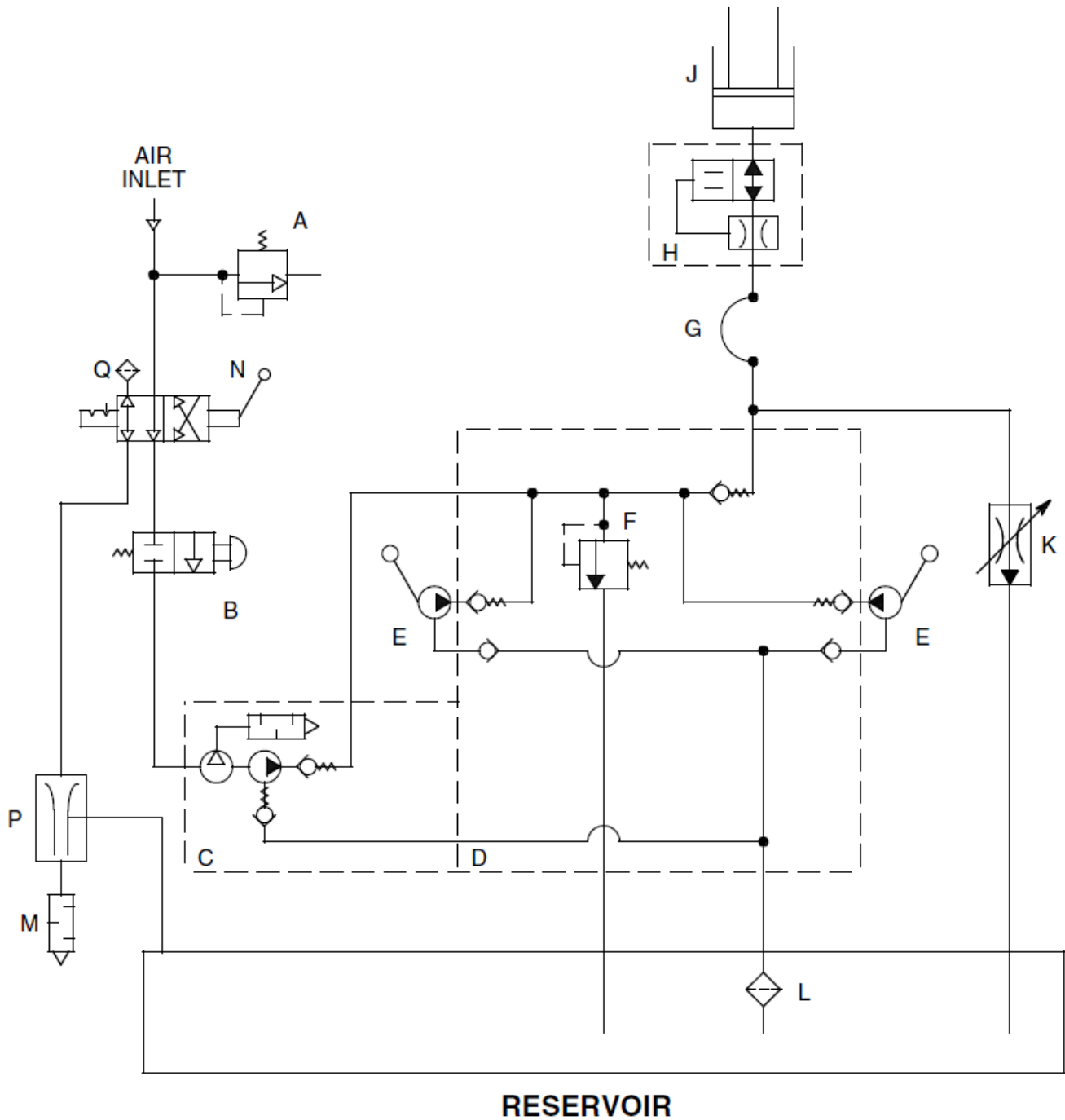

- A - AIR RELIEF VALVE
- B - AIR VALVE
- C - AIR PUMP
- D - VALVE BLOCK
- E - HAND PUMP
- F - SAFETY POP-OFF VALVE
- G - HYDRAULIC HOSE
- H - VELOCITY FUSE

- J - CYLINDER ASSEMBLY
- K - RELEASE VALVE
- L - OIL SCREEN
- M - MUFFLER
- N - FOUR-WAY VALVE
- P - VACUUM PUMP
- Q - FILTER/BREATHER

Parts List – Figure 1

When ordering replacement parts/kits, please specify model, serial number and color of your unit.

◆ PART OF REPAIR PARTS KIT

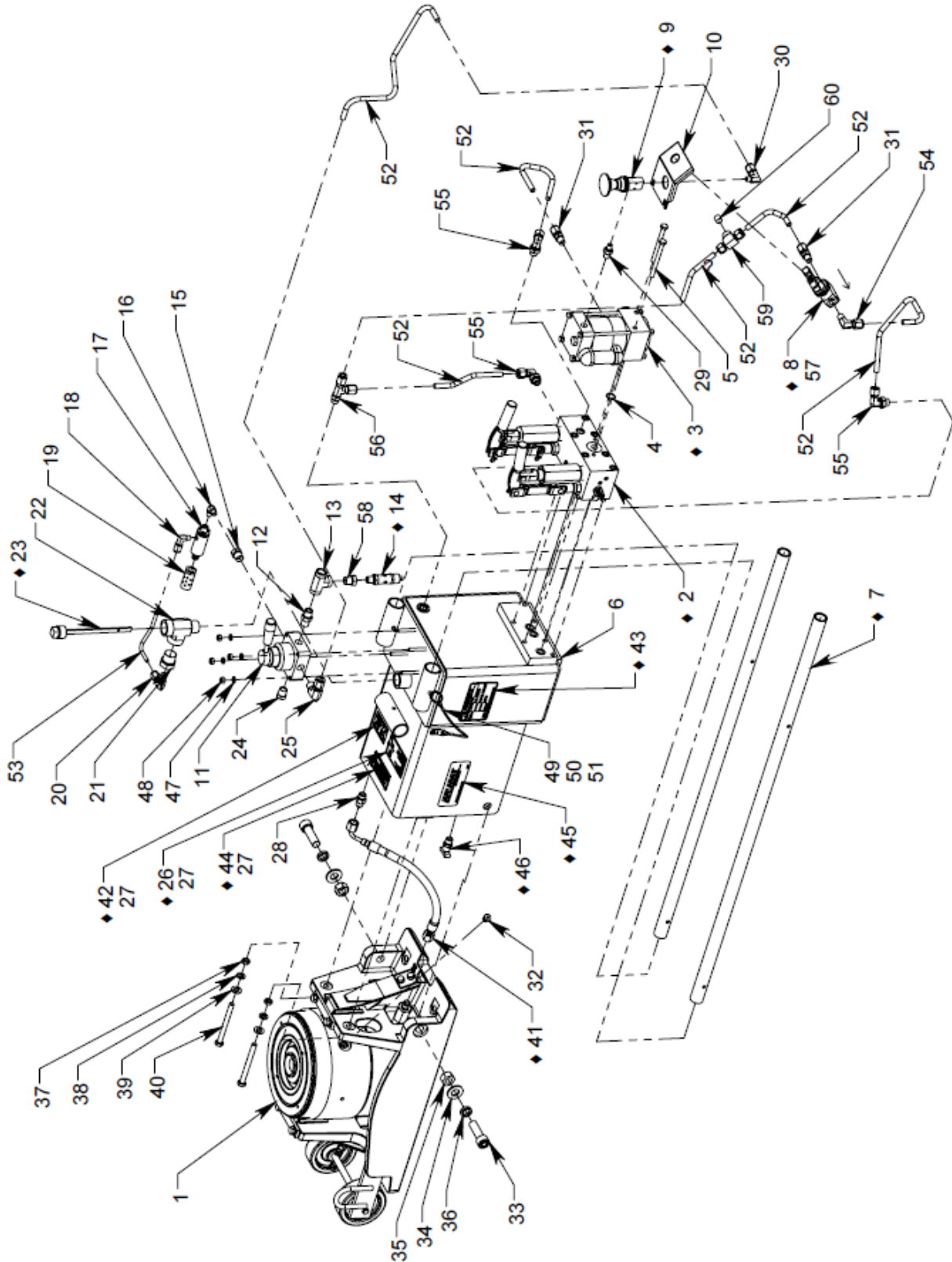

Parts List – Figure 1

When ordering replacement parts/kits, please specify model, serial number and color of your unit.

Item	Part Number	Description	Qty
1	892098	BASE & CYLINDER ASSY	1
2	892035	VALVE BLOCK & HAND PUMP ASSEMBLY	1
3	441-018	AIR PUMP	1
4	55925-016	O-RING	1
5	321-068	HHCS, 5/16-24 x 3-1/2 LG	2
6	892001	RESERVOIR WELDMENT	1
7	892003	PUMP HANDLE	2
8	85416	RELEASE VALVE	1
9	421-006	AIR VALVE	1
10	878041	MOUNT PLATE	1
11	86563	HAND VALVE	1
12	711-070	NIPPLE, BRASS, 3/8 MPT	1
13	713-018	TEE, BRASS, 3/8 FPT	1
14	425-001	AIR RELIEF VALVE	1
15	714-016	REDUCER, BRASS, 3/8 MPT x 1/8 FPT	1
16	712-089	ELBOW, 1/8 MPT	1
17	490-021	AIR OPERATED VACUUM PUMP	1
18	722-011	ELBOW, 1/4 TUBE x 1/8 MPT	1
19	472-003	MUFFLER	1
20	722-021	ELBOW, 1/4 TUBE x 1/4 MPT	1
21	714-007	REDUCER BUSHING, 3/4 MPT x 1/4 FPT	1
22	713-030	STREET TEE, 3/4 NPT	1
23	86564	PLUG AND DIPSTICK WELDMENT	1
24	483-004	BREATHER, 3/8 MPT	1
25	722-010	ELBOW, 3/8 TUBE x 3/8 MPT	1
26	86562	PLACARD, INSTRUCTION	1
27	397-010	SELF TAPPING SCREW, #6-32 x 3/16 LG	10
28	721-040	CONN., 3/8 MALE 37° x 3/8 SAE O-RING	1
29	711-024	NIPPLE, BRASS, 1/4 MPT x 1/8 MPT	1
30	722-028	ELBOW, 3/8 TUBE x 1/8 MPT	1
31	721-009	CONNECTOR, 3/8 TUBE x 1/4 MPT	2
32	717-021	SOCKET HEAD PLUG, 1/4 SAE O-RING	1
33	323-087	SHCS, 5/8-11 x 2" LG	2
34	362-006	FLAT WASHER, 5/8 SAE	2
35	351-006	HEX NUT, 5/8-11	2
36	363-043	HI-COLLAR SPLIT LOCKWASHER, 5/8	2
37	351-002	HEX NUT, 3/8-16	2
38	363-003	SPLIT LOCKWASHER, 3/8	2
39	361-001	FLAT WASHER, 3/8	2
40	321-053	HHCS, 3/8-16 x 4" LG	2
41	892012	HYDRAULIC PRESSURE HOSE	1
42	55989-14	PLACARD, 95 TONS	1

Parts List – Figure 1

When ordering replacement parts/kits, please specify model, serial number and color of your unit.

Item	Part Number	Description	Qty
43	55994	STICKER, FLUID	1
44	55997-2	NAME PLATE	1
45	55998-1	STICKER, MALABAR	2
46	424-060	DRAIN COCK VALVE, 1/4 MPT	1
47	363-001	SPLIT LOCKWASHER, 1/4	4
48	351-001	HEX NUT, 1/4-20	4
49	370-001	QUICK RELEASE PIN, 1/4 x 1.6 GRIP	2
50	326-021	BHCS, 10-32 x 1/2 LG	2
51	363-009	SPLIT LOCKWASHER, #10	2
52	732-010	TUBE, 3/8 OD x .065 WALL x 60" LG	AR
53	732-003	TUBE, 1/4 OD x .035 WALL x 5.1" LG	AR
54	722-014	ELBOW, 3/8 TUBE x 1/4 MPT	1
55	722-018	ELBOW, 3/8 TUBE x 3/8 SAE O-RING	3
56	723-014	TEE, 3/8 TUBE x 3/8 TUBE x 3/8 SAE	1
57	491-044	SAFETY LOCK WIRE .025 x 12" LG	AR
58	714-009	REDUCER, 3/8 MPT x 1/4 FPT	1
59	723-018	TEE, 3/8 T x 1/4 FPT x 3/8 T	1
60	717-006	HOLLOW HEX PLUG, 1/4 MPT	1

This page left blank intentionally.

Parts List – Figure 2

When ordering replacement parts/kits, please specify model, serial number and color of your unit.

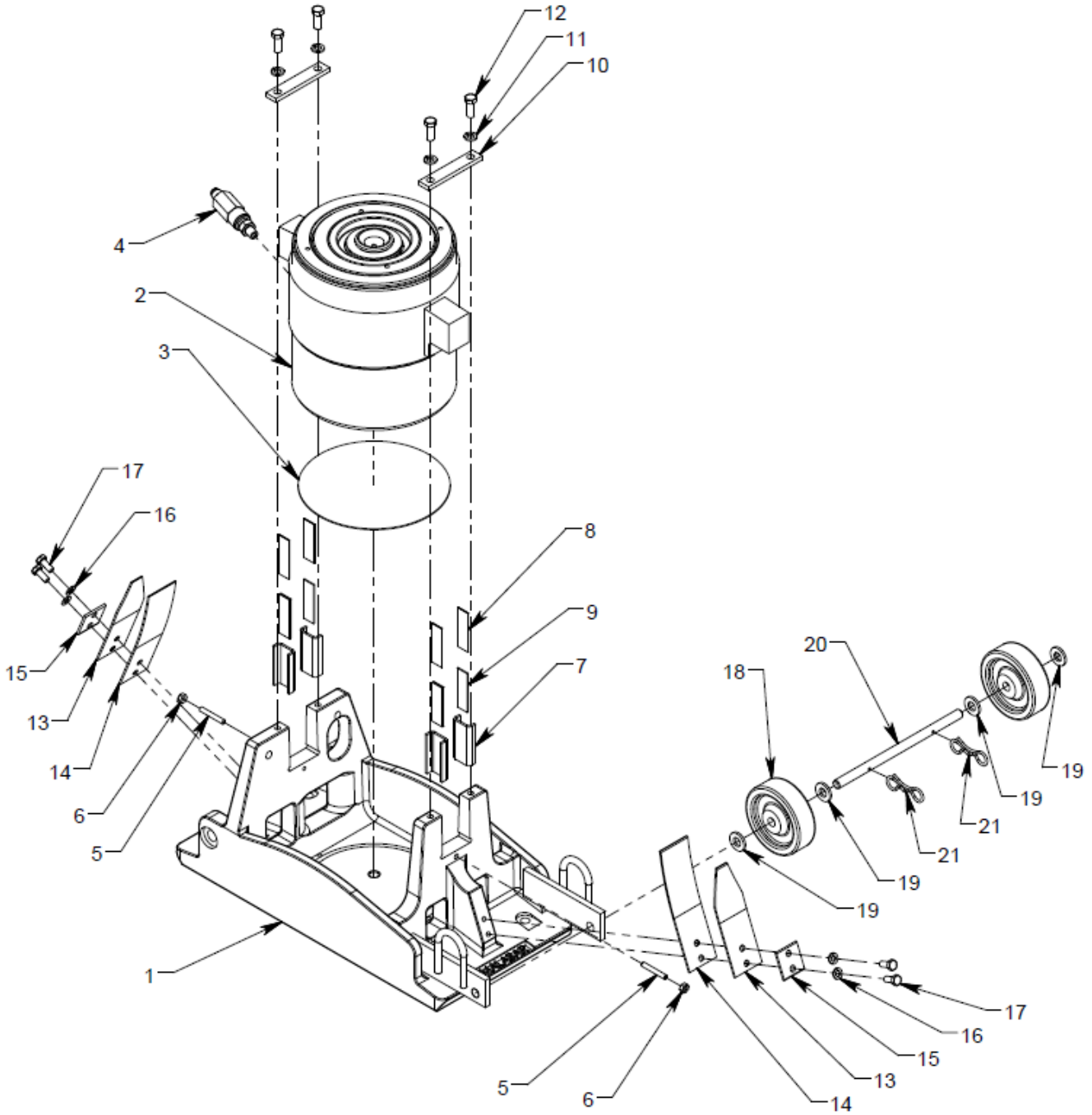

Parts List – Figure 2

When ordering replacement parts/kits, please specify model, serial number and color of your unit.

Item	Part Number	Description	Qty
	892098	Base & Cylinder Assembly; consists of:	
1	892014	BASE WELDMENT	1
2	885599-1	CYLINDER ASSEMBLY	1
3	86321	BEARING PAD, TEFLON	1
4	86328	VELOCITY FUSE ASSEMBLY	1
5	331-012	SETSCREW, 1/4-20 x 1-3/4	2
6	351-001	HEX NUT, 1/4-20	2
7	886611	SHOE	4
8	86612	SHIM	8
9	86619	SHIM, CUSHION	6
10	86326	BAR	2
11	363-003	SPLIT LOCKWASHER, 3/8	4
12	321-011	HHCS, 3/8-16 x 1" LG	4
13	86322	CENTERING SPRING, SHORT	2
14	86324	CENTERING SPRING, LONG	2
15	86325	SPRING KEEPER	2
16	363-002	SPLIT LOCKWASHER, 5/16	4
17	321-029	HHCS, 5/16-18 x 3/4 LG	4
18	492-119	WHEEL, 4" DIA	2
19	362-005	FLAT WASHER, 1/2 SAE	4
20	892007	WHEEL AXLE	1
21	372-030	BOW-TIE COTTER, 1/2 SHAFT	2

Parts List – Figure 3

When ordering replacement parts/kits, please specify model, serial number and color of your unit.

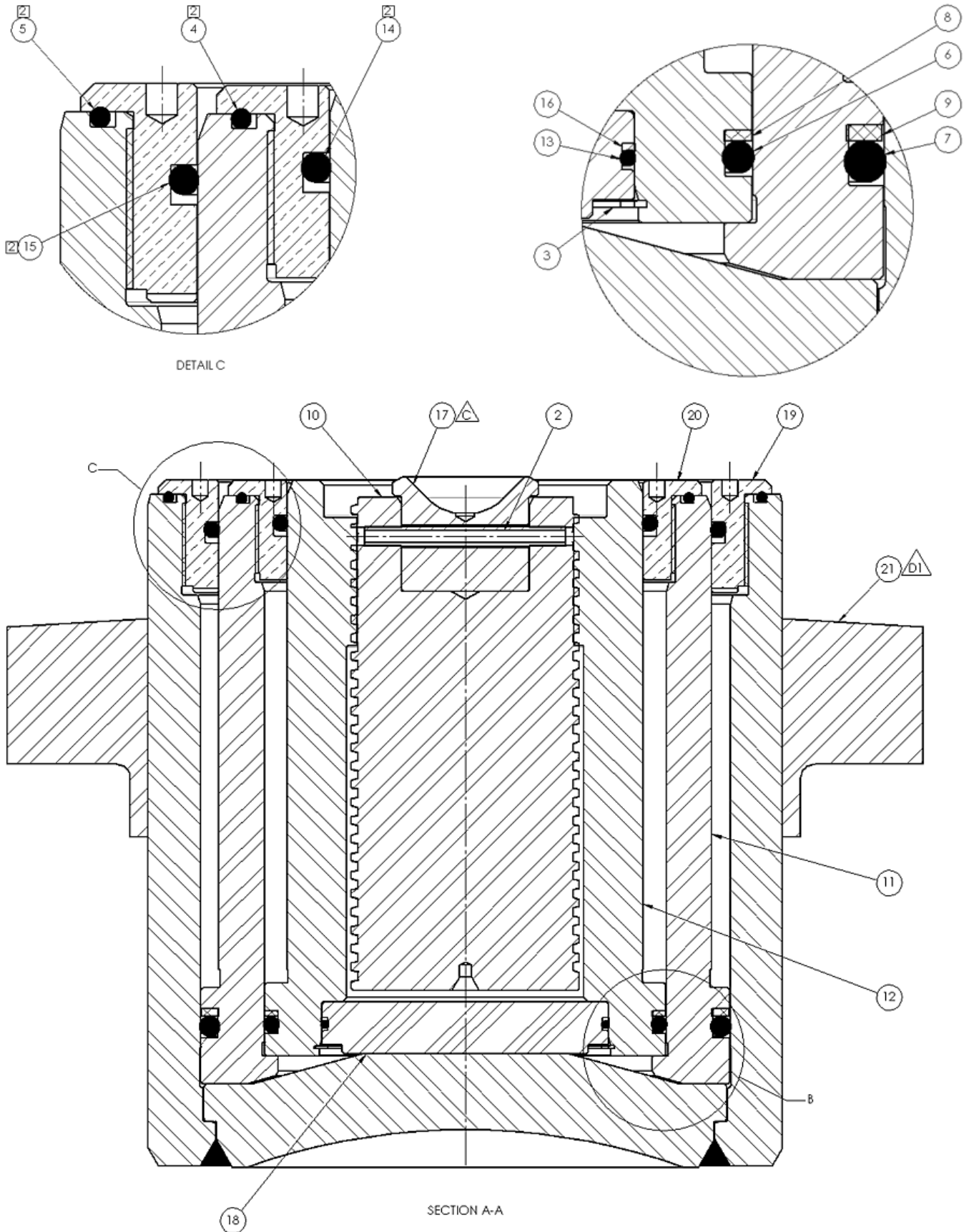

Parts List – Figure 3

When ordering replacement parts/kits, please specify model, serial number and color of your unit.

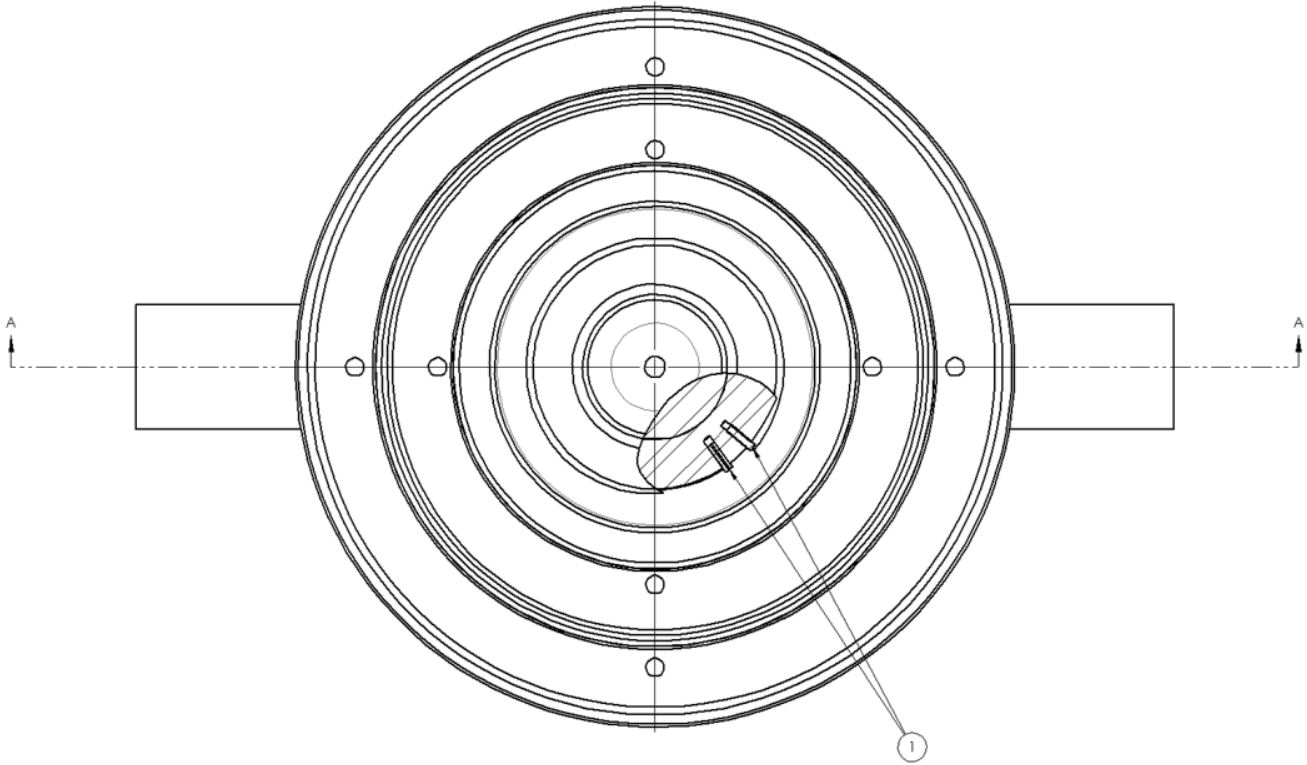

Item	Part Number	Description	Qty
	885599-1	Cylinder Assembly; consists of:	
1	371-015	ROLL PIN, 1/8 DIA x 3/8 LG	2
2	371-061	ROLL PIN, 1/4 DIA x 2-3/4 LG	1
3	55904-400	RETAINING RING	1
4	55925-258	O-RING	-
5	55925-266	O-RING	-
6	55925-354	O-RING	1
7	55925-440	O-RING	1
8	55929-354	BACK-UP RING	1
9	55929-440	BACK-UP RING	1
10	880418	EXTENSION SCREW	1
11	885504	OUTER PLUNGER	1
12	885506	INNER PLUNGER	1
13	HC-2000-154	O-RING, SERIES 2	1
14	HC-2000-352	O-RING, SERIES 2	-
15	HC-2000-364	O-RING, SERIES 2	-
16	HC-2023-154	BACKUP, PARBAK	1
17	R-3549	SHIP ADAPTER	1
18	R-3647	INNER PLUNGER DIAPHRAGM	1
19	TR-2924	OUTER STOP RING	1
20	TR-2925	INNER STOP RING	1
21	Z-12291	CYLINDER, MACHINED	1

Parts List – Figure 4

When ordering replacement parts/kits, please specify model, serial number and color of your unit.

Item	Part Number	Description	Qty
	892035	Valve Block & Hand Pump Assembly; consists of:	
1	892015	VALVE BLOCK	1
2	55620	PLUG WITH STOP PIN	2
3	55621	SPRING	2
4	412-004	BALL, CHROME STEEL, 1/4 DIA	5
5	55925-903	O-RING	2
6	55925-211	O-RING	1
7	55925-111	O-RING	1
8	55925-904	O-RING	1
9	55925-113	O-RING	3
10	323-009	SHCS, 3/8-24 x 3" LG	6
11	55001	PUMP FULCRUM	2
12	55002	PUMP PIN	6
13	372-028	BOW TIE COTTER	6
14	886657	PLUNGER, 13/16 DIA	1
15	755-019	WIPER	1
16	55922-16	BACK-UP RING	2
17	55922-9	BACK-UP RING	2
18	886656	BODY, 13/16 DIA	1
19	55024	GASKET	2
20	55615	PUMP LINK	2
21	55011	ANCHOR	2
22	352-004	HEX JAM NUT, 5/8-18	2
23	886659	PLUNGER, 7/16 DIA	1
24	755-018	WIPER	1
25	886658	BODY, 7/16 DIA	1
26	412-001	STEEL BALL, 3/8 DIA	1
27	79367	SPRING	1
28	55153	GUIDE, SPRING	1
29	55154H	SPRING	1
30	55148	SET SCREW	1
31	55568	OIL SCREEN	1
32	717-046	PLUG, HEX HEAD, 1/4 SAE	1
33	717-010	SOCKET PLUG, 1/16 MPT	4
34	329-012	SHCS, DRILLED HEAD, 1/4-20 x 3/8 LG	1
35	390-022	LEAD & WIRE SEAL	1



APPENDIX I

Safety Data Sheet MIL-PRF-5606 Hydraulic Fluid

Product Name: MOBIL AERO HFA
Revision Date: 01 Oct 2015
Page 1 of 12

SAFETY DATA SHEET

SECTION 1**PRODUCT AND COMPANY IDENTIFICATION****PRODUCT**

Product Name: MOBIL AERO HFA
Product Description: Base Oil and Additives
Product Code: 201550401020, 490110-00, 970584
Intended Use: Aviation hydraulic oil

COMPANY IDENTIFICATION

Supplier: EXXON MOBIL CORPORATION
22777 Springwoods Village Parkway
Spring, TX. 77253 USA

24 Hour Health Emergency 609-737-4411
Transportation Emergency Phone 800-424-9300 or 703-527-3887 CHEMTREC
Product Technical Information 800-662-4525
MSDS Internet Address <http://www.exxon.com>, <http://www.mobil.com>

SECTION 2**HAZARDS IDENTIFICATION**

This material is hazardous according to regulatory guidelines (see (M)SDS Section 15).

CLASSIFICATION:

Flammable liquid: Category 4.
Aspiration toxicant: Category 1.

LABEL:

Pictogram:



Signal Word: Danger

Hazard Statements:

H227: Combustible liquid. H304: May be fatal if swallowed and enters airways.

Precautionary Statements:

P210: Keep away from flames and hot surfaces. -- No smoking. P273: Avoid release to the environment. P280: Wear protective gloves and eye / face protection. P301 + P310: IF SWALLOWED: Immediately call a POISON CENTER or doctor/physician. P331: Do NOT induce vomiting. P370 + P378: In case of fire: Use water fog, foam, dry chemical or carbon dioxide (CO2) to extinguish. P403 + P235: Store in a well-ventilated place. Keep cool. P405: Store locked up. P501: Dispose of contents and container in accordance with local regulations.

Product Name: MOBIL AERO HFA
 Revision Date: 01 Oct 2015
 Page 2 of 12

Other hazard information:

HAZARD NOT OTHERWISE CLASSIFIED (HNOC): None as defined under 29 CFR 1910.1200.

PHYSICAL / CHEMICAL HAZARDS

Material can accumulate static charges which may cause an ignition. Material can release vapors that readily form flammable mixtures. Vapor accumulation could flash and/or explode if ignited. Combustible.

HEALTH HAZARDS

High-pressure injection under skin may cause serious damage. Excessive exposure may result in eye, skin, or respiratory irritation.

ENVIRONMENTAL HAZARDS

No significant hazards.

NFPA Hazard ID:	Health: 1	Flammability: 2	Reactivity: 0
HMIS Hazard ID:	Health: 1*	Flammability: 2	Reactivity: 0

NOTE: This material should not be used for any other purpose than the intended use in Section 1 without expert advice. Health studies have shown that chemical exposure may cause potential human health risks which may vary from person to person.

SECTION 3	COMPOSITION / INFORMATION ON INGREDIENTS
------------------	---

This material is defined as a mixture.

Hazardous Substance(s) or Complex Substance(s) required for disclosure

Name	CAS#	Concentration*	GHS Hazard Codes
2,6-DI-TERT-BUTYL-P-CRESOL	128-37-0	0.1 - < 1%	H400(M factor 1), H410(M factor 1)
DISTILLATES (PETROLEUM), HYDROTREATED LIGHT	64742-47-8	5 - < 10%	H304
HYDROTREATED LIGHT NAPHTHENIC DISTILLATE (PETROLEUM)	64742-53-6	50 - < 70%	H227, H304
HYDROTREATED MIDDLE DISTILLATE (PETROLEUM)	64742-46-7	20 - < 30%	H304
TRIPHENYL PHOSPHATE	115-86-6	0.1 - < 0.25%	H400(M factor 1), H410(M factor 1)

* All concentrations are percent by weight unless material is a gas. Gas concentrations are in percent by volume.

As per paragraph (i) of 29 CFR 1910.1200, formulation is considered a trade secret and specific chemical identity and exact percentage (concentration) of composition may have been withheld. Specific chemical identity and exact percentage composition will be provided to health professionals, employees, or designated representatives in accordance with applicable provisions of paragraph (i).

SECTION 4	FIRST AID MEASURES
------------------	---------------------------

INHALATION

Remove from further exposure. For those providing assistance, avoid exposure to yourself or others. Use adequate respiratory protection. If respiratory irritation, dizziness, nausea, or unconsciousness occurs, seek immediate medical assistance. If breathing has stopped, assist ventilation with a mechanical device or use mouth-to-mouth resuscitation.

SKIN CONTACT

Wash contact areas with soap and water. Remove contaminated clothing. Launder contaminated clothing before reuse. If product is injected into or under the skin, or into any part of the body, regardless of the appearance of the wound or its size, the individual should be evaluated immediately by a physician as a surgical emergency. Even though initial symptoms from high pressure injection may be minimal or absent, early surgical treatment within the first few hours may significantly reduce the ultimate extent of injury.

EYE CONTACT

Flush thoroughly with water. If irritation occurs, get medical assistance.

INGESTION

Seek immediate medical attention. Do not induce vomiting.

NOTE TO PHYSICIAN

If ingested, material may be aspirated into the lungs and cause chemical pneumonitis. Treat appropriately.

SECTION 5 FIRE FIGHTING MEASURES

EXTINGUISHING MEDIA

Appropriate Extinguishing Media: Use water fog, foam, dry chemical or carbon dioxide (CO₂) to extinguish flames.

Inappropriate Extinguishing Media: Straight Streams of Water

FIRE FIGHTING

Fire Fighting Instructions: Evacuate area. Prevent runoff from fire control or dilution from entering streams, sewers, or drinking water supply. Firefighters should use standard protective equipment and in enclosed spaces, self-contained breathing apparatus (SCBA). Use water spray to cool fire exposed surfaces and to protect personnel.

Unusual Fire Hazards: Combustible. Pressurized mists may form a flammable mixture.

Hazardous Combustion Products: Aldehydes, Incomplete combustion products, Oxides of carbon, Phosphorus oxides, Smoke, Fume, Sulfur oxides

FLAMMABILITY PROPERTIES

Flash Point [Method]: >82°C (180°F) [ASTM D-93]

Flammable Limits (Approximate volume % in air): LEL: 0.7 UEL: 7.0 [Estimated]

Autoignition Temperature: >225°C (437°F)

SECTION 6 ACCIDENTAL RELEASE MEASURES

NOTIFICATION PROCEDURES

In the event of a spill or accidental release, notify relevant authorities in accordance with all applicable

regulations. US regulations require reporting releases of this material to the environment which exceed the applicable reportable quantity or oil spills which could reach any waterway including intermittent dry creeks. The National Response Center can be reached at (800)424-8802.

PROTECTIVE MEASURES

Avoid contact with spilled material. Warn or evacuate occupants in surrounding and downwind areas if required due to toxicity or flammability of the material. See Section 5 for fire fighting information. See the Hazard Identification Section for Significant Hazards. See Section 4 for First Aid Advice. See Section 8 for advice on the minimum requirements for personal protective equipment. Additional protective measures may be necessary, depending on the specific circumstances and/or the expert judgment of the emergency responders.

For emergency responders: Respiratory protection: respiratory protection will be necessary only in special cases, e.g., formation of mists. Half-face or full-face respirator with filter(s) for dust/organic vapor or Self Contained Breathing Apparatus (SCBA) can be used depending on the size of spill and potential level of exposure. If the exposure cannot be completely characterized or an oxygen deficient atmosphere is possible or anticipated, SCBA is recommended. Work gloves that are resistant to hydrocarbons are recommended. Gloves made of polyvinyl acetate (PVA) are not water-resistant and are not suitable for emergency use. Chemical goggles are recommended if splashes or contact with eyes is possible. Small spills: normal antistatic work clothes are usually adequate. Large spills: full body suit of chemical resistant, antistatic material is recommended.

SPILL MANAGEMENT

Land Spill: Eliminate all ignition sources (no smoking, flares, sparks or flames in immediate area). Stop leak if you can do it without risk. All equipment used when handling the product must be grounded. Do not touch or walk through spilled material. Prevent entry into waterways, sewer, basements or confined areas. A vapor suppressing foam may be used to reduce vapors. Use clean non-sparking tools to collect absorbed material. Absorb or cover with dry earth, sand or other non-combustible material and transfer to containers. Large Spills: Water spray may reduce vapor; but may not prevent ignition in closed spaces. Recover by pumping or with suitable absorbent.

Water Spill: Stop leak if you can do it without risk. Confine the spill immediately with booms. Warn other shipping. Remove from the surface by skimming or with suitable absorbents. Seek the advice of a specialist before using dispersants.

Water spill and land spill recommendations are based on the most likely spill scenario for this material; however, geographic conditions, wind, temperature, (and in the case of a water spill) wave and current direction and speed may greatly influence the appropriate action to be taken. For this reason, local experts should be consulted. Note: Local regulations may prescribe or limit action to be taken.

ENVIRONMENTAL PRECAUTIONS

Large Spills: Dike far ahead of liquid spill for later recovery and disposal. Prevent entry into waterways, sewers, basements or confined areas.

SECTION 7	HANDLING AND STORAGE
------------------	-----------------------------

HANDLING

Avoid contact with skin. Avoid prolonged breathing of mists and heated vapor. Prevent small spills and leakage to avoid slip hazard. Material can accumulate static charges which may cause an electrical spark (ignition source). When the material is handled in bulk, an electrical spark could ignite any flammable vapors from liquids or residues that may be present (e.g., during switch-loading operations). Use proper bonding and/or ground procedures. However, bonding and grounds may not eliminate the hazard from static

accumulation. Consult local applicable standards for guidance. Additional references include American Petroleum Institute 2003 (Protection Against Ignitions Arising out of Static, Lightning and Stray Currents) or National Fire Protection Agency 77 (Recommended Practice on Static Electricity) or CENELEC CLC/TR 50404 (Electrostatics - Code of practice for the avoidance of hazards due to static electricity).

Static Accumulator: This material is a static accumulator.

STORAGE

The container choice, for example storage vessel, may effect static accumulation and dissipation. Keep container closed. Handle containers with care. Open slowly in order to control possible pressure release. Store in a cool, well-ventilated area. Storage containers should be grounded and bonded. Fixed storage containers, transfer containers and associated equipment should be grounded and bonded to prevent accumulation of static charge.

SECTION 8 EXPOSURE CONTROLS / PERSONAL PROTECTION

EXPOSURE LIMIT VALUES

Exposure limits/standards (Note: Exposure limits are not additive)

Substance Name	Form	Limit / Standard		NOTE	Source
2,6-DI-TERT-BUTYL-P-CRESOL	Inhalable fraction and vapor	TWA	2 mg/m3	N/A	ACGIH
DISTILLATES (PETROLEUM), HYDROTREATED LIGHT [total hydrocarbon vapor]	Non-Aerosol	TWA	200 mg/m3	Skin	ACGIH
HYDROTREATED LIGHT NAPHTHENIC DISTILLATE (PETROLEUM)	Mist.	TWA	5 mg/m3	N/A	OSHA Z1
HYDROTREATED LIGHT NAPHTHENIC DISTILLATE (PETROLEUM)	Inhalable fraction.	TWA	5 mg/m3	N/A	ACGIH
HYDROTREATED LIGHT NAPHTHENIC DISTILLATE (PETROLEUM)	Mist.	TWA	5 mg/m3	N/A	ACGIH
HYDROTREATED MIDDLE DISTILLATE (PETROLEUM)	Mist.	TWA	5 mg/m3	N/A	OSHA Z1
HYDROTREATED MIDDLE DISTILLATE (PETROLEUM)	Inhalable fraction.	TWA	5 mg/m3	N/A	ACGIH
TRIPHENYL PHOSPHATE		TWA	3 mg/m3	N/A	OSHA Z1
TRIPHENYL PHOSPHATE		TWA	3 mg/m3	N/A	ACGIH

Exposure limits/standards for materials that can be formed when handling this product: When mists/aerosols can occur the following are recommended: 5 mg/m³ - ACGIH TLV (inhalable fraction), 5 mg/m³ - OSHA PEL.

NOTE: Limits/standards shown for guidance only. Follow applicable regulations.

No biological limits allocated.

ENGINEERING CONTROLS

The level of protection and types of controls necessary will vary depending upon potential exposure conditions.

Control measures to consider:

Use explosion-proof ventilation equipment to stay below exposure limits.

PERSONAL PROTECTION

Personal protective equipment selections vary based on potential exposure conditions such as applications, handling practices, concentration and ventilation. Information on the selection of protective equipment for use with this material, as provided below, is based upon intended, normal usage.

Respiratory Protection: If engineering controls do not maintain airborne contaminant concentrations at a level which is adequate to protect worker health, an approved respirator may be appropriate. Respirator selection, use, and maintenance must be in accordance with regulatory requirements, if applicable. Types of respirators to be considered for this material include:

No special requirements under ordinary conditions of use and with adequate ventilation.

For high airborne concentrations, use an approved supplied-air respirator, operated in positive pressure mode. Supplied air respirators with an escape bottle may be appropriate when oxygen levels are inadequate, gas/vapor warning properties are poor, or if air purifying filter capacity/rating may be exceeded.

Hand Protection: Any specific glove information provided is based on published literature and glove manufacturer data. Glove suitability and breakthrough time will differ depending on the specific use conditions. Contact the glove manufacturer for specific advice on glove selection and breakthrough times for your use conditions. Inspect and replace worn or damaged gloves. The types of gloves to be considered for this material include:

If prolonged or repeated contact is likely, chemical resistant gloves are recommended. If contact with forearms is likely, wear gauntlet style gloves.

Eye Protection: If contact is likely, safety glasses with side shields are recommended.

Skin and Body Protection: Any specific clothing information provided is based on published literature or manufacturer data. The types of clothing to be considered for this material include:

If prolonged or repeated contact is likely, chemical, and oil resistant clothing is recommended.

Specific Hygiene Measures: Always observe good personal hygiene measures, such as washing after handling the material and before eating, drinking, and/or smoking. Routinely wash work clothing and protective equipment to remove contaminants. Discard contaminated clothing and footwear that cannot be cleaned. Practice good housekeeping.

ENVIRONMENTAL CONTROLS

Comply with applicable environmental regulations limiting discharge to air, water and soil. Protect the environment by applying appropriate control measures to prevent or limit emissions.

SECTION 9

PHYSICAL AND CHEMICAL PROPERTIES

Note: Physical and chemical properties are provided for safety, health and environmental considerations only and may not fully represent product specifications. Contact the Supplier for additional information.

GENERAL INFORMATION

Physical State: Liquid

Color: Red

Product Name: MOBIL AERO HFA
 Revision Date: 01 Oct 2015
 Page 7 of 12

Odor: Characteristic
Odor Threshold: N/D

IMPORTANT HEALTH, SAFETY, AND ENVIRONMENTAL INFORMATION

Relative Density (at 15 °C): 0.88
Flammability (Solid, Gas): N/A
Flash Point [Method]: >82°C (180°F) [ASTM D-93]
Flammable Limits (Approximate volume % in air): LEL: 0.7 UEL: 7.0 [Estimated]
Autoignition Temperature: >225°C (437°F)
Boiling Point / Range: N/D
Decomposition Temperature: N/D
Vapor Density (Air = 1): N/D
Vapor Pressure: [N/D at 20 °C]
Evaporation Rate (n-butyl acetate = 1): N/D
pH: N/A
Log Pow (n-Octanol/Water Partition Coefficient): N/D
Solubility in Water: Negligible
Viscosity: 13.8 cSt (13.8 mm2/sec) at 40 °C | 5.1 cSt (5.1 mm2/sec) at 100°C [ASTM D 445]
Oxidizing Properties: See Hazards Identification Section.

OTHER INFORMATION

Freezing Point: N/D
Melting Point: N/A
Pour Point: -60°C (-76°F) [ASTM D97]
DMSO Extract (mineral oil only), IP-346: < 3 %wt

SECTION 10 STABILITY AND REACTIVITY

REACTIVITY: See sub-sections below.

STABILITY: Material is stable under normal conditions.

CONDITIONS TO AVOID: Open flames and high energy ignition sources.

MATERIALS TO AVOID: Strong oxidizers

HAZARDOUS DECOMPOSITION PRODUCTS: Material does not decompose at ambient temperatures.

POSSIBILITY OF HAZARDOUS REACTIONS: Hazardous polymerization will not occur.

SECTION 11 TOXICOLOGICAL INFORMATION

INFORMATION ON TOXICOLOGICAL EFFECTS

Hazard Class	Conclusion / Remarks
Inhalation	
Acute Toxicity: No end point data for material.	Minimally Toxic. Based on assessment of the components.
Irritation: No end point data for material.	Elevated temperatures or mechanical action may form vapors, mist, or fumes which may be irritating to the eyes, nose, throat, or lungs.

Product Name: MOBIL AERO HFA
 Revision Date: 01 Oct 2015
 Page 8 of 12

Ingestion	
Acute Toxicity: No end point data for material.	Minimally Toxic. Based on assessment of the components.
Skin	
Acute Toxicity: No end point data for material.	Minimally Toxic. Based on assessment of the components.
Skin Corrosion/Irritation: No end point data for material.	May dry the skin leading to discomfort and dermatitis. Based on assessment of the components.
Eye	
Serious Eye Damage/Irritation: No end point data for material.	May cause mild, short-lasting discomfort to eyes. Based on assessment of the components.
Sensitization	
Respiratory Sensitization: No end point data for material.	Not expected to be a respiratory sensitizer.
Skin Sensitization: No end point data for material.	Not expected to be a skin sensitizer. Based on assessment of the components.
Aspiration: Data available.	May be fatal if swallowed and enters airways. Based on physico-chemical properties of the material.
Germ Cell Mutagenicity: No end point data for material.	Not expected to be a germ cell mutagen. Based on assessment of the components.
Carcinogenicity: No end point data for material.	Not expected to cause cancer. Based on assessment of the components.
Reproductive Toxicity: No end point data for material.	Not expected to be a reproductive toxicant. Based on assessment of the components.
Lactation: No end point data for material.	Not expected to cause harm to breast-fed children.
Specific Target Organ Toxicity (STOT)	
Single Exposure: No end point data for material.	Not expected to cause organ damage from a single exposure.
Repeated Exposure: No end point data for material.	Not expected to cause organ damage from prolonged or repeated exposure. Based on assessment of the components.

TOXICITY FOR SUBSTANCES

NAME	ACUTE TOXICITY
2,6-DI-TERT-BUTYL-P-CRESOL	Oral Lethality: LD50 0.89 g/kg (Rat)

OTHER INFORMATION

For the product itself:

Repeated and/or prolonged exposure may cause irritation to the skin, eyes, or respiratory tract. Small amounts of liquid aspirated into the lungs during ingestion or from vomiting may cause chemical pneumonitis or pulmonary edema.

Contains:

Base oil severely refined: Not carcinogenic in animal studies. Representative material passes IP-346, Modified Ames test, and/or other screening tests. Dermal and inhalation studies showed minimal effects; lung non-specific infiltration of immune cells, oil deposition and minimal granuloma formation. Not sensitizing in test animals.

The following ingredients are cited on the lists below: None.

--REGULATORY LISTS SEARCHED--

Product Name: MOBIL AERO HFA
Revision Date: 01 Oct 2015
Page 9 of 12

1 = NTP CARC
2 = NTP SUS

3 = IARC 1
4 = IARC 2A

5 = IARC 2B
6 = OSHA CARC

SECTION 12 ECOLOGICAL INFORMATION

The information given is based on data available for the material, the components of the material, and similar materials.

ECOTOXICITY

Material -- Not expected to be harmful to aquatic organisms.

MOBILITY

More volatile component -- Highly volatile, will partition rapidly to air. Not expected to partition to sediment and wastewater solids.

Less volatile component -- Low solubility and floats and is expected to migrate from water to the land. Expected to partition to sediment and wastewater solids.

PERSISTENCE AND DEGRADABILITY

Biodegradation:

Components -- Expected to be inherently biodegradable

BIOACCUMULATION POTENTIAL

Majority of components -- Has the potential to bioaccumulate, however metabolism or physical properties may reduce the bioconcentration or limit bioavailability.

SECTION 13 DISPOSAL CONSIDERATIONS

Disposal recommendations based on material as supplied. Disposal must be in accordance with current applicable laws and regulations, and material characteristics at time of disposal.

DISPOSAL RECOMMENDATIONS

Product is suitable for burning in an enclosed controlled burner for fuel value or disposal by supervised incineration at very high temperatures to prevent formation of undesirable combustion products. Protect the environment. Dispose of used oil at designated sites. Minimize skin contact. Do not mix used oils with solvents, brake fluids or coolants.

REGULATORY DISPOSAL INFORMATION

RCRA Information: The unused product, in our opinion, is not specifically listed by the EPA as a hazardous waste (40 CFR, Part 261D), nor is it formulated to contain materials which are listed as hazardous wastes. It does not exhibit the hazardous characteristics of ignitability, corrosivity or reactivity and is not formulated with contaminants as determined by the Toxicity Characteristic Leaching Procedure (TCLP). However, used product may be regulated.

Empty Container Warning Empty Container Warning (where applicable): Empty containers may contain residue and can be dangerous. Do not attempt to refill or clean containers without proper instructions. Empty drums should be

Product Name: MOBIL AERO HFA
Revision Date: 01 Oct 2015
Page 10 of 12

completely drained and safely stored until appropriately reconditioned or disposed. Empty containers should be taken for recycling, recovery, or disposal through suitably qualified or licensed contractor and in accordance with governmental regulations. DO NOT PRESSURISE, CUT, WELD, BRAZE, SOLDER, DRILL, GRIND, OR EXPOSE SUCH CONTAINERS TO HEAT, FLAME, SPARKS, STATIC ELECTRICITY, OR OTHER SOURCES OF IGNITION. THEY MAY EXPLODE AND CAUSE INJURY OR DEATH.

SECTION 14 TRANSPORT INFORMATION

LAND (DOT)

Proper Shipping Name: COMBUSTIBLE LIQUID, N.O.S. (Distillates (Petroleum), Hydrotreated Light)
Hazard Class & Division: COMBUSTIBLE LIQUID
ID Number: NA1993
Packing Group: III
ERG Number: 128
Label(s): NONE
Transport Document Name: NA1993, COMBUSTIBLE LIQUID, N.O.S. (Distillates (Petroleum), Hydrotreated Light), COMBUSTIBLE LIQUID, PG III

Footnote: This material is not regulated under 49 CFR in a container of 119 gallon capacity or less when transported solely by land, as long as the material is not a hazardous waste, a marine pollutant, or specifically listed as a hazardous substance.

LAND (TDG): Not Regulated for Land Transport

SEA (IMDG): Not Regulated for Sea Transport according to IMDG-Code

Marine Pollutant: No

AIR (IATA): Not Regulated for Air Transport

SECTION 15 REGULATORY INFORMATION

OSHA HAZARD COMMUNICATION STANDARD: This material is considered hazardous in accordance with OSHA HazCom 2012, 29 CFR 1910.1200.

Listed or exempt from listing/notification on the following chemical inventories: AICS, DSL, ENCS, IECSC, KECI, PICCS, TCSI, TSCA

EPCRA SECTION 302: This material contains no extremely hazardous substances.

SARA (311/312) REPORTABLE HAZARD CATEGORIES: Fire. Immediate Health. Delayed Health.

SARA (313) TOXIC RELEASE INVENTORY: This material contains no chemicals subject to the supplier notification requirements of the SARA 313 Toxic Release Program.

Product Name: MOBIL AERO HFA
 Revision Date: 01 Oct 2015
 Page 11 of 12

The following ingredients are cited on the lists below:

Chemical Name	CAS Number	List Citations
DISTILLATES (PETROLEUM), HYDROTREATED LIGHT	64742-47-8	1, 17, 18
HYDROTREATED LIGHT NAPHTHENIC DISTILLATE (PETROLEUM)	64742-53-6	1, 4, 13, 17, 18
HYDROTREATED MIDDLE DISTILLATE (PETROLEUM)	64742-46-7	1, 4, 17, 18

--REGULATORY LISTS SEARCHED--

1 = ACGIH ALL	6 = TSCA 5a2	11 = CA P65 REPRO	16 = MN RTK
2 = ACGIH A1	7 = TSCA 5e	12 = CA RTK	17 = NJ RTK
3 = ACGIH A2	8 = TSCA 6	13 = IL RTK	18 = PA RTK
4 = OSHA Z	9 = TSCA 12b	14 = LA RTK	19 = RI RTK
5 = TSCA 4	10 = CA P65 CARC	15 = MI 293	

Code key: CARC=Carcinogen; REPRO=Reproductive

SECTION 16	OTHER INFORMATION
-------------------	--------------------------

N/D = Not determined, N/A = Not applicable

KEY TO THE H-CODES CONTAINED IN SECTION 3 OF THIS DOCUMENT (for information only):

H227: Combustible liquid; Flammable Liquid, Cat 4
 H304: May be fatal if swallowed and enters airways; Aspiration, Cat 1
 H400: Very toxic to aquatic life; Acute Env Tox, Cat 1
 H410: Very toxic to aquatic life with long lasting effects; Chronic Env Tox, Cat 1

THIS SAFETY DATA SHEET CONTAINS THE FOLLOWING REVISIONS:

Revision Changes:

- Section 01: Company Mailing Address information was modified.
- Section 05: Hazardous Combustion Products information was modified.
- Section 15: List Citations Table information was modified.
- Section 15: National Chemical Inventory Listing information was modified.
- Section 14: Marine Pollutant information was modified.
- Composition: Component Table information was modified.
- Section 08: Exposure Limits Table information was modified.
- Section 16: Revision Information - Implementation of GHS requirements phrase. information was deleted.

The information and recommendations contained herein are, to the best of ExxonMobil's knowledge and belief, accurate and reliable as of the date issued. You can contact ExxonMobil to insure that this document is the most current available from ExxonMobil. The information and recommendations are offered for the user's consideration and examination. It is the user's responsibility to satisfy itself that the product is suitable for the intended use. If buyer repackages this product, it is the user's responsibility to insure proper health, safety and other necessary information is included with and/or on the container. Appropriate warnings and safe-handling procedures should be provided to handlers and users. Alteration of this document is strictly prohibited. Except to the extent required by law,



Product Name: MOBIL AERO HFA
Revision Date: 01 Oct 2015
Page 12 of 12

re-publication or retransmission of this document, in whole or in part, is not permitted. The term, "ExxonMobil" is used for convenience, and may include any one or more of ExxonMobil Chemical Company, Exxon Mobil Corporation, or any affiliates in which they directly or indirectly hold any interest.

Internal Use Only

MHC: 2A, 0, 0, 0, 1, 1

PPEC: C

DGN: 2005454XUS (552975)

Copyright 2002 Exxon Mobil Corporation, All rights reserved