

**Models: 693A, 695A
Hydraulic Power Unit
Diesel Powered**

04/2026 – Rev. 11

For Spare Parts, Operations & Service Manuals or Service Needs
Scan the QR code or visit tronair.com/pages/tronair-information-center



The Tronair Group of Companies: Tronair | Columbus Jack | Eagle | Malabar International

Tronair, Inc.
1 Air Cargo Pkwy East
Swanton, OH 43558

Phone: (419) 866-6301 | 800-426-6301
Web: www.tronair.com
Email: sales@tronair.com

REVISION	DATE	TEXT AFFECTED
01	09/2017	Original release
02	09/2018	Modified Parts List
03	08/2021	Added section 5.13 Infrequent HPU Use and updated 10.0 Maintenance
04	05/2022	Modified 10.3 Engine Components, 10.4.1 Hydraulic Pump Replacement Parts, 11.2.1 Spare Parts
05	08/2022	Modified 10.4.1.a Hydraulic Pump Replacement Seal Kits
06	11/2022	Modified Parts List
07	06/2023	Major revision
08	10/2024	Modified 10.6.1 Pressure Filter Element, 10.6.5 Pressure Filter Assembly, and 10.16 External Components
10	06/2025	Modified 10.6.5 Pressure Filter Assembly with Electric Clogging Indicator
11	04/2026	Modified 10.4.1 Hydraulic Pump Replacement Parts

TABLE OF CONTENTS

PAGE

1.0	PRODUCT INFORMATION	1
1.1	DESCRIPTION.....	1
1.2	MODEL & SERIAL NUMBER.....	1
1.3	MANUFACTURER.....	1
1.4	FUNCTION.....	1
1.5	REQUIREMENTS	1
2.0	SAFETY INFORMATION	1
2.1	USAGE AND SAFETY INFORMATION	1
2.2	EXPLANATION OF WARNING & DANGER SIGNS	1
2.3	COMPONENT SAFETY FEATURES.....	2
2.4	FUNCTIONAL SAFETY FEATURES	2
2.5	PERSONAL PROTECTION EQUIPMENT	2
2.6	SAFETY GUIDELINES	2
2.7	GENERAL COMMENT	2
3.0	PREPARATION PRIOR TO FIRST USE	2
3.1	GENERAL.....	2
3.2	PRE-USE INSPECTION	2
4.0	TRAINING	3
4.1	TRAINING REQUIREMENTS	3
4.2	TRAINING PROGRAM	3
4.3	OPERATOR TRAINING	3
5.0	OPERATION	3
5.1	OPERATING PARAMETERS	3
5.2	NUMERICAL VALUES.....	3
5.2.1	Model	3
5.2.2	Physical.....	3
5.2.3	Hydraulic Pump.....	3
5.2.4	Engine.....	4
5.2.5	Filters	4
5.2.6	Fill Pump.....	4
5.3	LOCATION & LAYOUT OF CONTROLS	5
5.3.1	Panel Controls.....	5
5.3.2	Electrical Control Panel.....	6
5.3.3	Controls, Engine Compartment.....	10
5.3.4	Rear Controls.....	15
5.3.5	Split System Controls.....	16
5.4	HPU MODES	17
5.4.1	Bypass Mode	17
5.4.2	Parasitic Mode	17
5.4.3	Aircraft Mode.....	17
5.5	START UP PROCEDURES	17
5.5.1	Initial Start Up of the HPU	17
5.6	PRELIMINARY ADJUSTMENTS FOR OPERATION.....	17
5.6.1	Flow Control Adjustment.....	17
5.6.2	Pressure Control Adjustment	18
5.6.3	Reservoir Selector Valve Operation	18
5.7	BLEEDING AIR FROM SYSTEM.....	18
5.7.1	To Easily Purge the Unit of Air	18
5.8	SPLIT SYSTEM OPERATION	19
5.8.1	To Operate the Split System	19
5.9	ELECTRIC FILL PUMP OPERATION.....	19
5.10	SAMPLE VALVE.....	19
5.11	EMERGENCY SHUT DOWN PROCEDURE	19
5.12	DESCRIPTION OF ALARM SYSTEMS	20
5.12.1	High Fluid Temperature Fault.....	20
5.12.2	High and Low Reservoir Level Fault	20
5.12.3	Clogged Filter Warning	20
5.12.4	Red Stop Fault Light	20
5.12.5	Yellow Warning Light	20
5.13	INFREQUENT HPU USE.....	20
5.13.1	Infrequent HPU Use Start Up Procedure	20
6.0	PACKAGING AND STORAGE	21
6.1	PACKAGING REQUIREMENTS.....	21
6.2	HANDLING	21
6.3	PACKAGING PROTECTION	21

6.4	LABELING OF PACKAGING	21
6.5	STORAGE COMPATIBILITY	21
6.6	STORAGE ENVIRONMENT	21
6.7	STORAGE SPACE AND HANDLING FACILITIES	21
7.0	TRANSPORTATION	21
8.0	SERVICING	22
8.1	GENERAL (DAILY CHECKS)	22
8.2	SHORT TERM PREVENTIVE MAINTENANCE SCHEDULE	22
9.0	TROUBLE SHOOTING	24
9.1	HPU WILL NOT START	24
9.2	NO FLOW	24
9.3	REDUCED FLOW	24
9.4	NO PRESSURE or REDUCED PRESSURE	24
9.5	FLUID OVERHEATS	24
9.6	ELECTRIC PUMP IS NOT PUMPING FLUID	24
10.0	MAINTENANCE	25
10.1	GENERAL (Daily Checks)	25
10.2	FILTERS	25
10.3	ENGINE COMPONENTS	26
10.4	HYDRAULIC PUMP	27
10.4.1	Hydraulic Pump Replacement Parts	27
10.4.1.a	Hydraulic Pump Replacement Seal Kits	28
10.5	HYDRAULIC FLUID	28
10.6	FILTERS	28
10.6.1	Pressure Filter Element	29
10.6.2	Return Filter Element	30
10.6.3	Fill Pump Filter Element	31
10.6.4	Desiccant Air Filter	32
10.6.5	Pressure Filter Assembly with Electric Filter Clogging Indicator	33
10.6.6	Return Filter and Manifold Assembly	34
10.7	HYDRAULIC HOSES	35
10.8	FUEL TANK	36
10.9	CONTROL PANEL	37
10.10	CONTROL BLOCK ASSEMBLY	38
10.10.1	Control Manifold Assembly	38
10.10.2	System Pressure Relief Valve	39
10.11	FLOW CONTROL MANIFOLD ASSEMBLY	40
10.11.1	Flow Control Valve	41
10.12	RESERVOIR ASSEMBLY	42
10.13	RETURN SYSTEM PRESSURE RELIEF VALVE	44
10.14	ELECTRICAL COMPONENTS	46
10.15	CASE DRAIN	48
10.15.1	Case Cooler	48
10.15.2	Para Cooler Upper	49
10.15.3	Para Cooler Lower	50
10.16	EXTERNAL COMPONENTS	52
10.16.1	Hydraulic Coupling	54
10.17	FLOWMETER ASSEMBLY	55
10.18	ELECTRIC RESERVOIR LEVEL	56
10.19	FILL PUMP	57
10.20	TOWING TRAILER	58
10.21	REPLACEMENT LABELS PARTS LISTS	59
10.21.1	Base Unit	59
10.21.2	Fluid Labels	59
10.21.3	Filter Element Kit Labels	59
11.0	PROVISION OF SPARES	60
11.1	SOURCE OF SPARE PARTS	60
11.2	RECOMMENDED SPARE PARTS LISTS	60
11.2.1	Spare Parts	60
12.0	CALIBRATION OF INSTRUMENTATION	60
12.1	SOURCE OF CALIBRATION	60
13.0	IN SERVICE SUPPORT	60
14.0	GUARANTEES/LIMITATION OF LIABILITY	61
15.0	APPENDICES	61

This product can not be modified without the written approval of Tronair, Inc. Any modifications done without written approval voids all warranties and releases Tronair, Inc., its suppliers, distributors, employees, or financial institutions from any liability from consequences that may occur. Only Tronair OEM replacement parts shall be used.

1.0 PRODUCT INFORMATION

1.1 DESCRIPTION

Hydraulic Power Unit, Tier 4 final

Model Number: Fluid Type:

693A..... Aviation Phosphate Ester, Type IV, Skydrol

695A..... Aviation Phosphate Ester, Type V, Hyjet

1.2 MODEL & SERIAL NUMBER

Reference nameplate on unit.

1.3 MANUFACTURER

TRONAIR, Inc.

1 Air Cargo Pkwy East

Swanton, Ohio 43558 USA

Telephone: (419) 866-6301 or 800-426-6301

Fax: (419) 867-0634

E-mail: sales@tronair.com

Website: www.tronair.com

1.4 FUNCTION

The Hydraulic Power Unit (HPU) provides a source of clean, pressurized hydraulic fluid for performing required aircraft maintenance. A diesel engine drives a pressure compensated piston pump. Filters are provided on the pressure and return systems. A bypass (dump) valve allows starting and stopping of the unit under a no-load, safe condition. The unit may use either the aircraft or on-board HPU reservoir. Cooling is provided for continuous operation.

1.5 REQUIREMENTS

The HPU must run on low sulfur diesel fuel. The fuel filter is a disposable lubricity additive type designed to supply adequate lubrication to the fuel pump. The filter must be changed every 500 hours of running time.

2.0 SAFETY INFORMATION

2.1 USAGE AND SAFETY INFORMATION

The HPU provides pressurized hydraulic fluid for performing aircraft maintenance.

To ensure safe operations please read the following statements and understand their meaning. Also refer to your equipment manufacturer's manual for other important safety information. This manual contains safety precautions which are explained below. Please read carefully.



WARNING! — Warning is used to indicate the presence of a hazard that **can cause severe personal injury, death, or substantial property damage** if the warning notice is ignored.

CAUTION! — Caution is used to indicate the presence of a hazard that **will or can cause minor personal injury or property damage** if the caution notice is ignored.

2.2 EXPLANATION OF WARNING & DANGER SIGNS



Accidental Starts! Always turn off and lock out the battery switch before servicing this HPU. Only qualified service personnel may service this equipment. Read and understand the technical manual before servicing this equipment.



Rotating Parts! Keep hands, feet, hair, and clothing away from all moving parts to prevent injury. Never operate the HPU with covers, shrouds, or guards removed.



Hot Surfaces! Engine components such as turbo chargers, exhaust pipes, and mufflers will remain hot after the engine has been shut down. Allow engine to cool before servicing.



Batteries! Batteries give off flammable hydrogen gas and can explode if ignited. When servicing, do not allow arcing, sparks, or open flame near the battery. Acid and arcing from a ruptured battery can cause fires and additional damage.



Fuel Hazard! Use only approved containers for transferring fuel. Shut down HPU before refueling. Fires and explosions can occur if the fuel tank is not grounded. Ground fuel tank before and during fuel transfer. Clean up all fuel spills immediately.

2.2 EXPLANATION OF WARNING & DANGER SIGNS *(continued)*



Carbon Monoxide! Engine exhaust fumes can kill. If indoors, always pipe or vent exhaust fumes to a suitable exhaust duct. Never locate engine exhaust near air conditioner intake ducts.



CALIFORNIA PROPOSITION 65 – DIESEL ENGINES Diesel engine exhaust and some of its constituents are known by the State of California to cause cancer, birth defects, and other reproductive harm.

No Access for Unauthorized Persons! Only qualified personnel may service this equipment.

Read Operation and Service Manual! Read and understand the operation and service manual before using this equipment. Failure to follow operating instructions could result in death or serious injury.

Lockout! Shut down engine. Turn off and lockout battery switch before servicing. If working near the batteries or the battery switch, also disconnect the negative battery cable, at the battery, on the fuel pump side of the engine.

Loud Noise Hazard! Ear protection must be worn while operating this equipment.

2.3 COMPONENT SAFETY FEATURES

- Sheet metal panels
- Pressure and return system relief valves
- Hand actuated rear drum brakes
- Fan guard
- Muffler guard
- Circuit breakers

2.4 FUNCTIONAL SAFETY FEATURES

- Emergency shut off switch
- Timed engine shut down
- Battery shut off switch
- Fluid sample shut off valve

2.5 PERSONAL PROTECTION EQUIPMENT

- Safety glasses must be worn when operating the HPU.
- Hearing protection must be worn when operating the HPU.
- Additional equipment recommended by the fluid manufacturer (gloves, etc.). **Reference Appendix pertaining to Material Safety Data Sheet pertaining to fluid(s).**

2.6 SAFETY GUIDELINES

- Operator must be properly trained prior to operating the HPU.
- The HPU battery switch must be in the Off position before servicing the HPU.

2.7 GENERAL COMMENT

The HPU is intended to be operated by personnel trained in the proper use in conjunction with the aircraft maintenance manual.

The HPU must be used in accordance with the Operation and Service Manuals and the intended aircraft.

3.0 PREPARATION PRIOR TO FIRST USE

3.1 GENERAL

Prior to operating the HPU, the user should become familiar with this Operator Manual.

3.2 PRE-USE INSPECTION

CAUTION!



A pre-use inspection must be carried out prior to each use to ensure safe operation of the HPU. Failure to carry out these procedures listed below may result in severe damage to the HPU or prevent efficient operation.

1. Unit.....Visually inspect outside of HPU for loose hardware, loose parts, frayed wires/cables and general appearance.
2. Radiator.....Open radiator access door and remove radiator cap (cold only). Ensure that coolant is up to the bottom of the fill neck. Service as required.
3. Engine Hoses.....Check integrity of hoses and clamps for tightness.
4. Fuel Level.....Turn power on and check fuel level. Top up as required with fuel.
5. Def Level.....Turn power on and check Def level. Top up as required.
6. Engine.....Inspect all fuel lines and fittings for traces of fuel leakage. Visually inspect cylinder block oil pan and valve covers for oil leakage.
7. Oil Level.....Remove dipstick to ensure oil level is at full mark. Replenish as required.
8. Fan Belt.....Check belt for correct tension. Look for wear.
9. Tires.....Check integrity of tires and tread wear and pressure
10. Brakes.....Check for proper operation

4.0 TRAINING

4.1 TRAINING REQUIREMENTS

The employer of the operator is responsible for providing a training program sufficient for the safe operation of the HPU.

4.2 TRAINING PROGRAM

The employer provided operator training program should cover safety procedures concerning use of the HPU in and around the intended aircraft at the intended aircraft servicing location.

4.3 OPERATOR TRAINING

The operator training should provide the required training for safe operation of the HPU.

NOTE: Maintenance and Trouble Shooting are to be performed by a skilled and trained technician.

5.0 OPERATION

5.1 OPERATING PARAMETERS

- The user shall use the HPU in accordance with the aircraft manufacturer's instructions.
- The user shall operate the HPU in accordance with the Technical and Operator Manuals.
- The employer of the operator shall provide all necessary training.

5.2 NUMERICAL VALUES

5.2.1 Model

Model Number:	Fluid Type:
693A.....	Aviation Phosphate Ester, Type IV, Skydrol
695A.....	Aviation Phosphate Ester, Type V, Hyjet

5.2.2 Physical

Weight (Dry).....	10,000 lbs (4536 kg)
Length.....	156.5 in (397.5 cm)
Width.....	83.5 in (212 cm)
Height.....	95.25 in (242 cm)
Turn Radius.....	12.5 ft (3.81 m)
Pressure Hoses.....	50 ft (15.24 m) Standard Length
	-16 (1 in, 25.4 mm) Working Diameter
Return Hoses.....	50 ft (15.24 m) Standard Length
	-24 (1½ in, 38.1 mm) Working Diameter
Fill Pump Hose.....	50 ft (15.24 m) Standard Length
	-6 (¾ in, 9.53 mm) Working Diameter

5.2.3 Hydraulic Pump

- A pressure compensated, adjustable maximum volume piston pump.
- Maximum flow at 1800 rpm..... 63 gpm (239 lpm)
- Maximum operating pressure..... 5,000 psi (345 bar)
- System pressure relief valve setting..... 3,250 psi (224 bar), 5,250 psi (362 bar) when key switch engaged
- Performance Curve

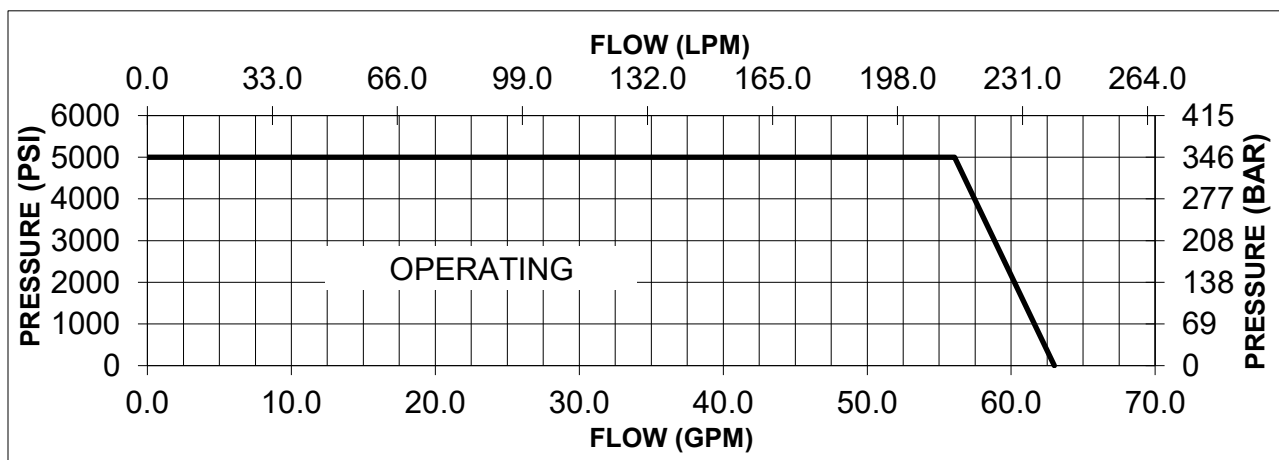

5.2.4 Engine

Fiat N67ENTHW21.00... 6.7 Liter turbocharged after cooled, 6 cylinder diesel engine
Horsepower 200 bhp (151 KW) at 1800 rpm
Weight 1800 lb (816 kg) includes ATS
Idle Speed 1150 rpm +/- 25 rpm
Electrical System 24 volt, negative ground
Lubricating oil 14 quarts (13.2 liters)
Coolant 24 quarts (22.7 liters)
Def Fluid 20 quarts (18.9 liters)

5.2.5 Filters

Pressure 2 micron rating, non-bypass high collapse microglass type. Non-cleanable element.
Return 5 micron rating, 25 psi (1.72 bar) bypass microglass type. Non-cleanable element.
Fill Pump 2 micron rating, non-bypass microglass type. Non-cleanable element.
Air/Desiccant 3 micron filter, silica gel desiccant type. Non-cleanable element.

5.2.6 Fill Pump

A ½ HP electric motor drives a vane pump to supply pressurized fluid for servicing aircraft reservoirs.

Flow 1.5 gpm (5.7 lpm)
Pressure 65 psi (4.5 bar)
Relief 70 psi (4.8 bar)

5.3 LOCATION & LAYOUT OF CONTROLS

5.3.1 Panel Controls

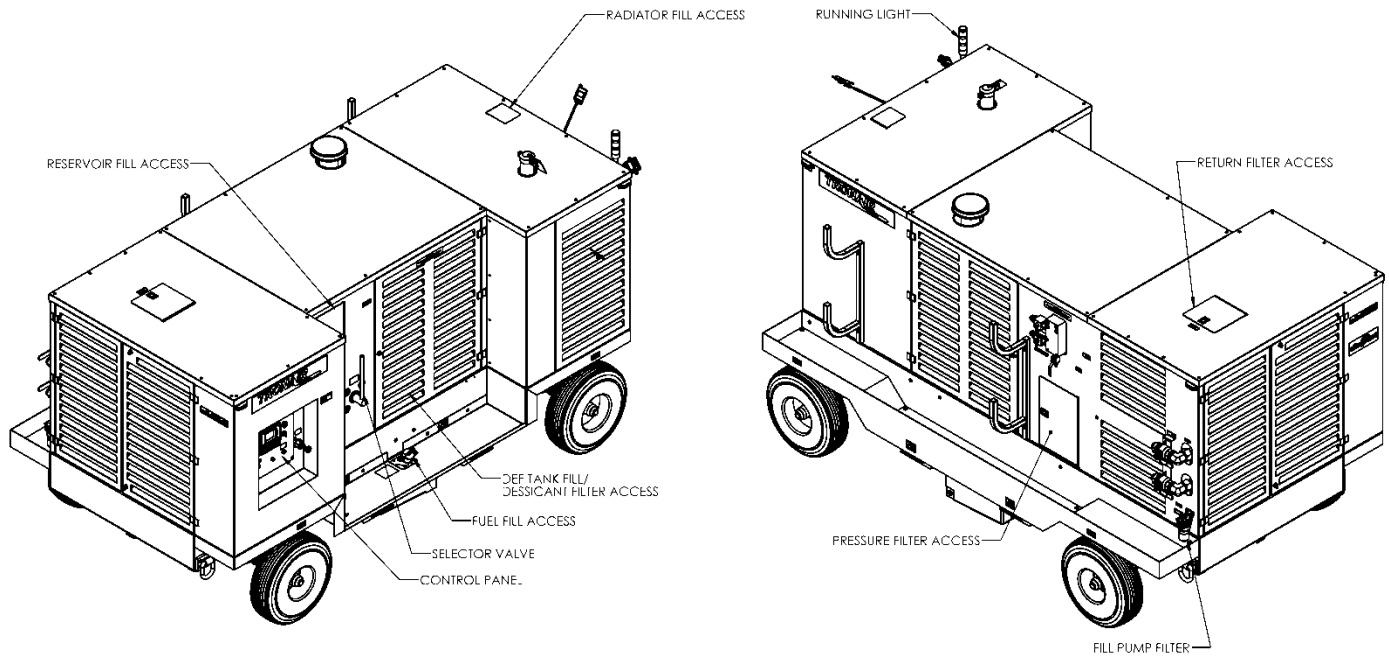

Control Panel	See Section 5.3.2
Reservoir Fill Access	Locking cap for servicing the HPU reservoir
Desiccant Filter	Access to the reservoir air filter/desiccant filter
Fill Pump Filter	Access for fill pump filter
Running Light	Displays green LED light when unit is running
Radiator Fill Access	Access to top of radiator
Selector Valve	For selecting between using the aircraft reservoir or the HPU reservoir
Fuel Fill Access	Access to the diesel fill cap
DEF Tank Fill Access	Access to the DEF tank fill cap
Pressure Filter Access	Access to the pressure filter
Return Filter Access	Access to the return filter

5.3.2 Electrical Control Panel

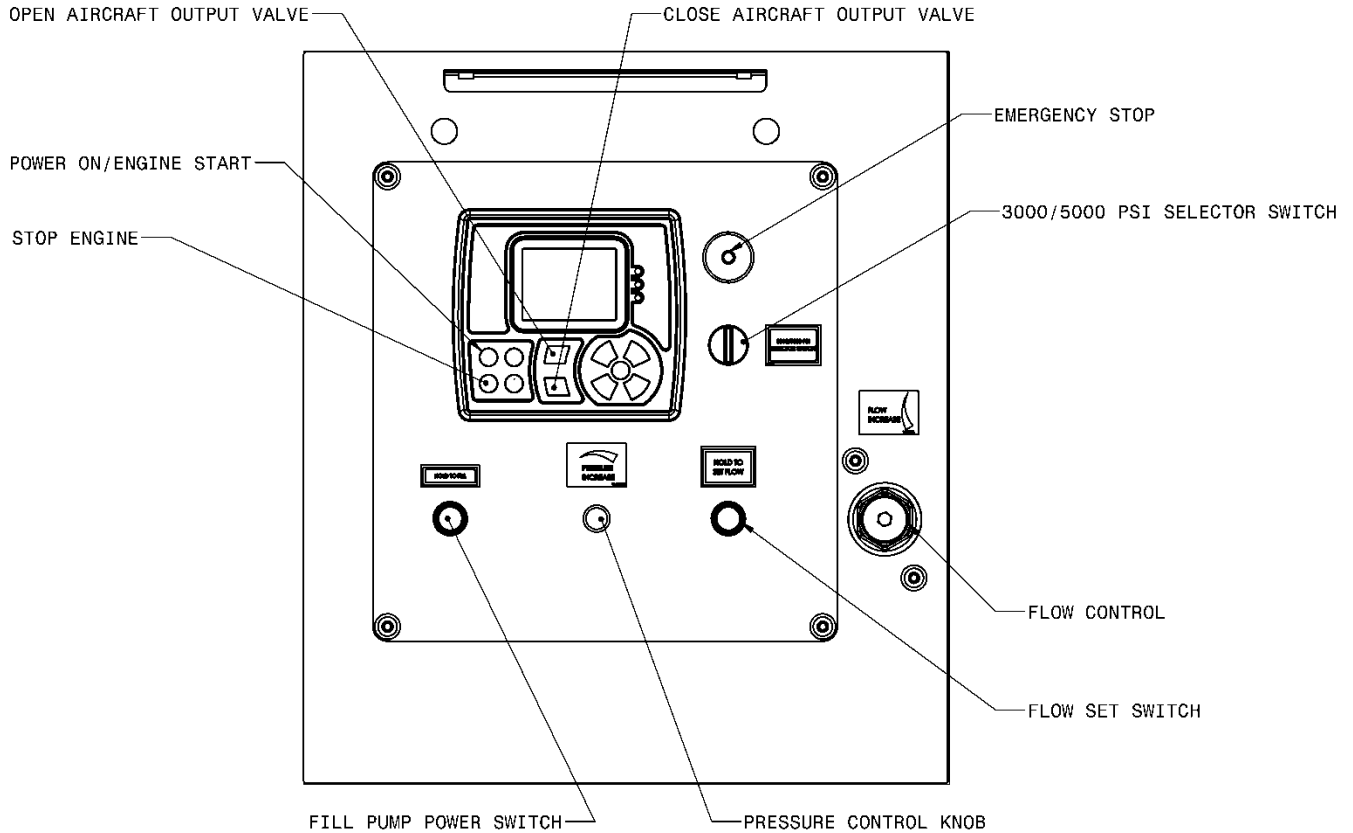

Power On/Engine Start	Push once to turn on 24VDC power. Push once power is on to start engine
Stop Engine	Sends engine to idle state for 1 minute before shutting down
Emergency Stop	Immediately shuts off power to the HPU and engine. For emergency use only.
Open Aircraft Output Valve	Opens Aircraft Output Valve connecting the HPU to the aircraft
Close Aircraft Output Valve	Closes Aircraft Output Valve disconnecting the HPU from the aircraft
3000/5000 Psi Selector Switch	Unit defaults to max pressure of 3000 psi. Turn key to allow for max pressure of 5000 psi
Flow Control	This control is used to set the flow required from the HPU
Flow Set Switch	Sends unit to bypass mode to allow flow setting before connecting to aircraft
Pressure Control Knob	This control is used to set the system pressure of the HPU during operation
Fill Pump Power Switch	Hold to use reservoir service pump

5.3.2 Electrical Control Panel (continued)

MAIN SCREEN



HYDRAULIC SCREEN



5.3.2 Electrical Control Panel (continued)

DEF SCREEN



ENGINE SCREEN



5.3.2 Electrical Control Panel (continued)

INFORMATION SCREEN



5.3.3 Controls, Engine Compartment

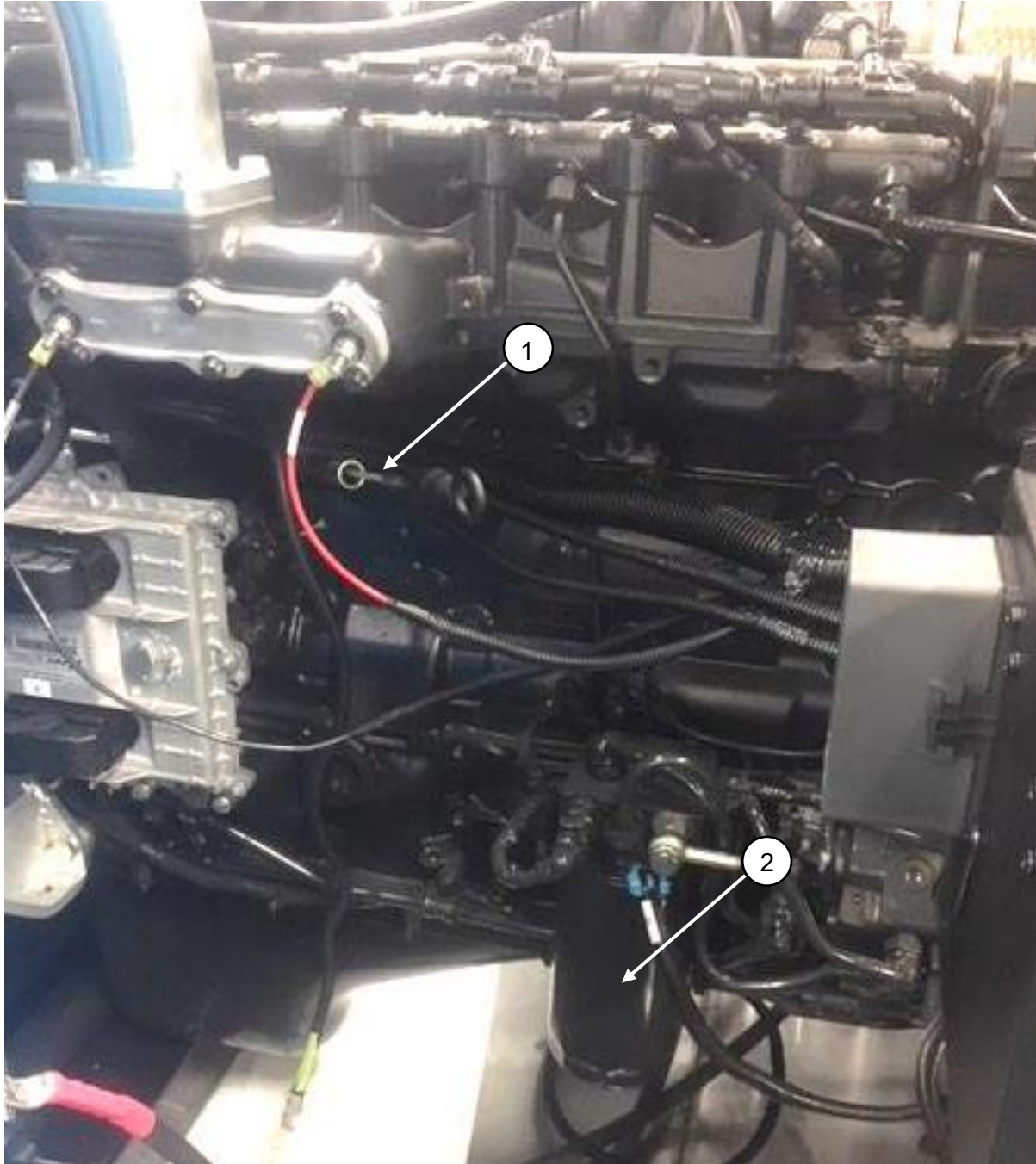

- 1. Oil Level Dipstick
- 2. Fuel Filter

5.3.3 Controls, Engine Compartment (*continued*)

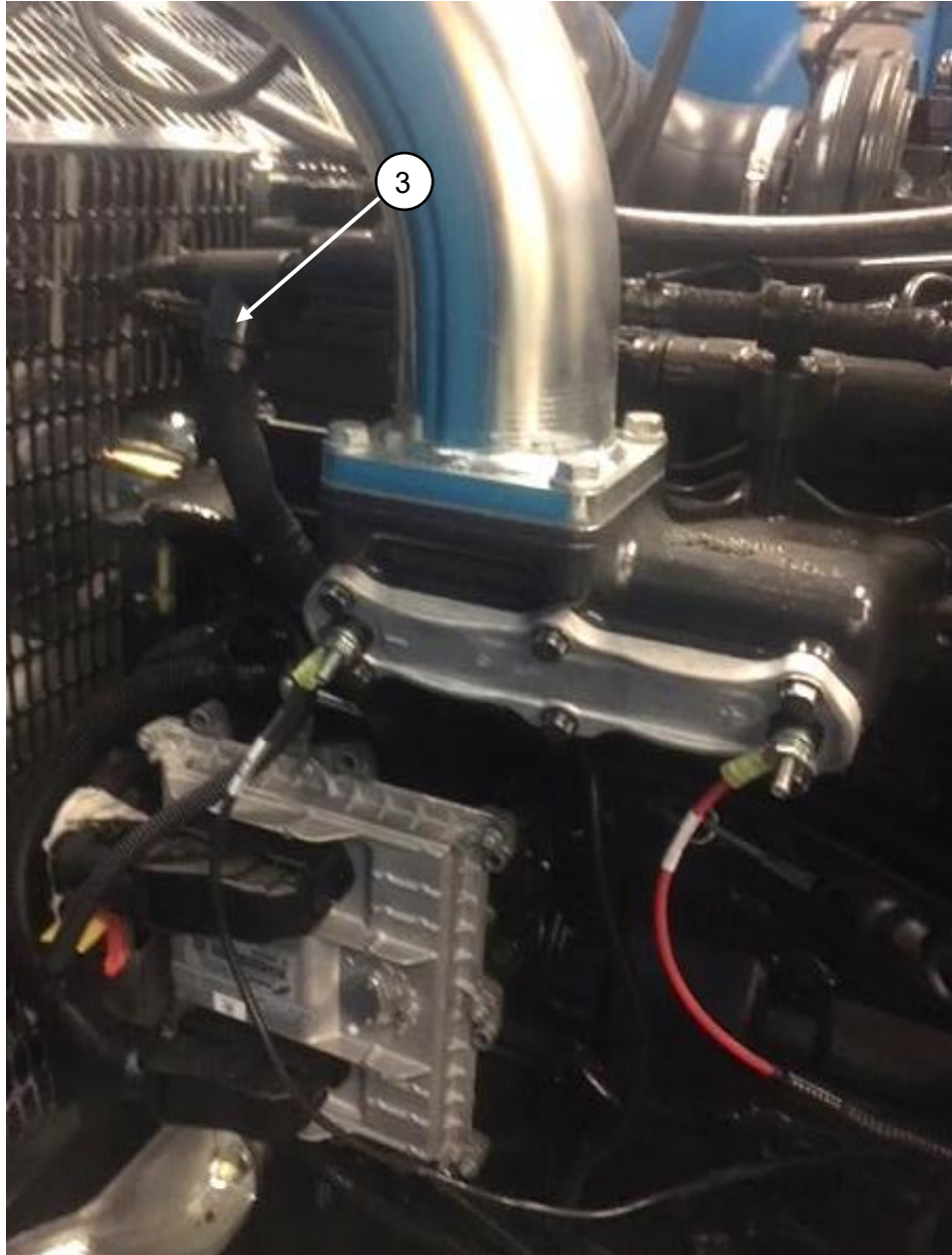

3. Oil Fill

5.3.3 Controls, Engine Compartment (*continued*)

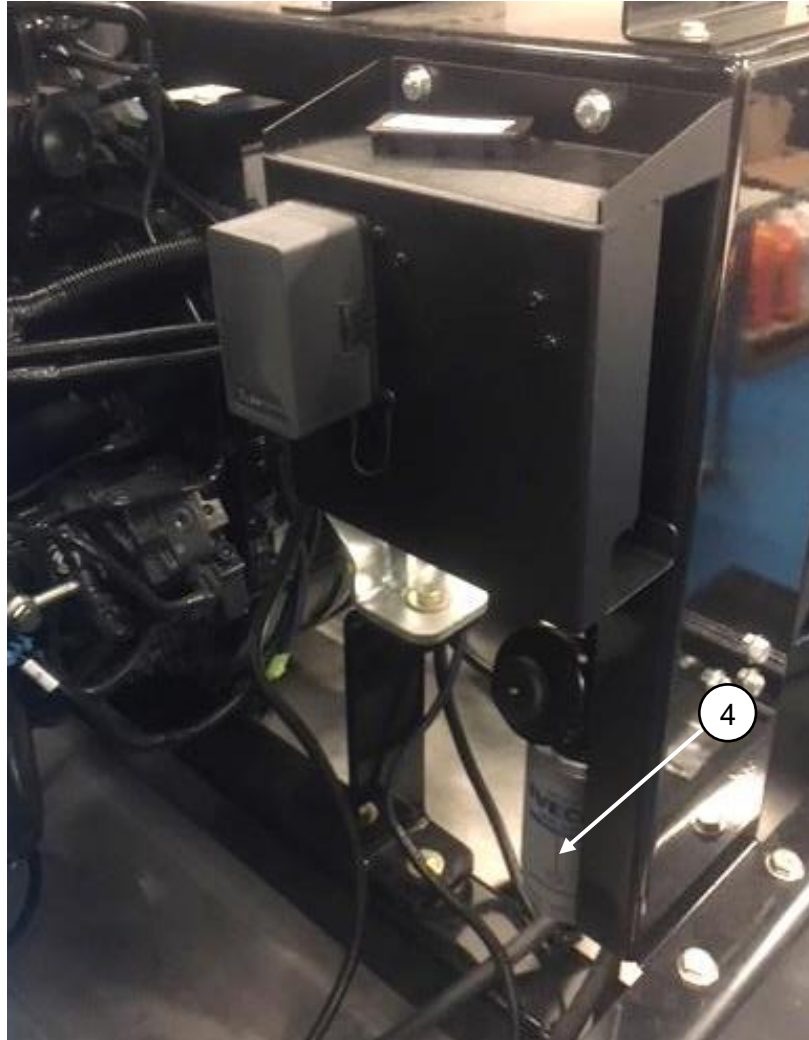

4. Water in Fuel Filter

5.3.3 Controls, Engine Compartment (continued)



5. Battery Switch

Battery Switch	Connects and disconnects Pos. 24 Volt battery cable. Must be in the ON position for unit to run HPU is shipped with switch in the OFF position
----------------	--

5.3.3 Controls, Engine Compartment (*continued*)

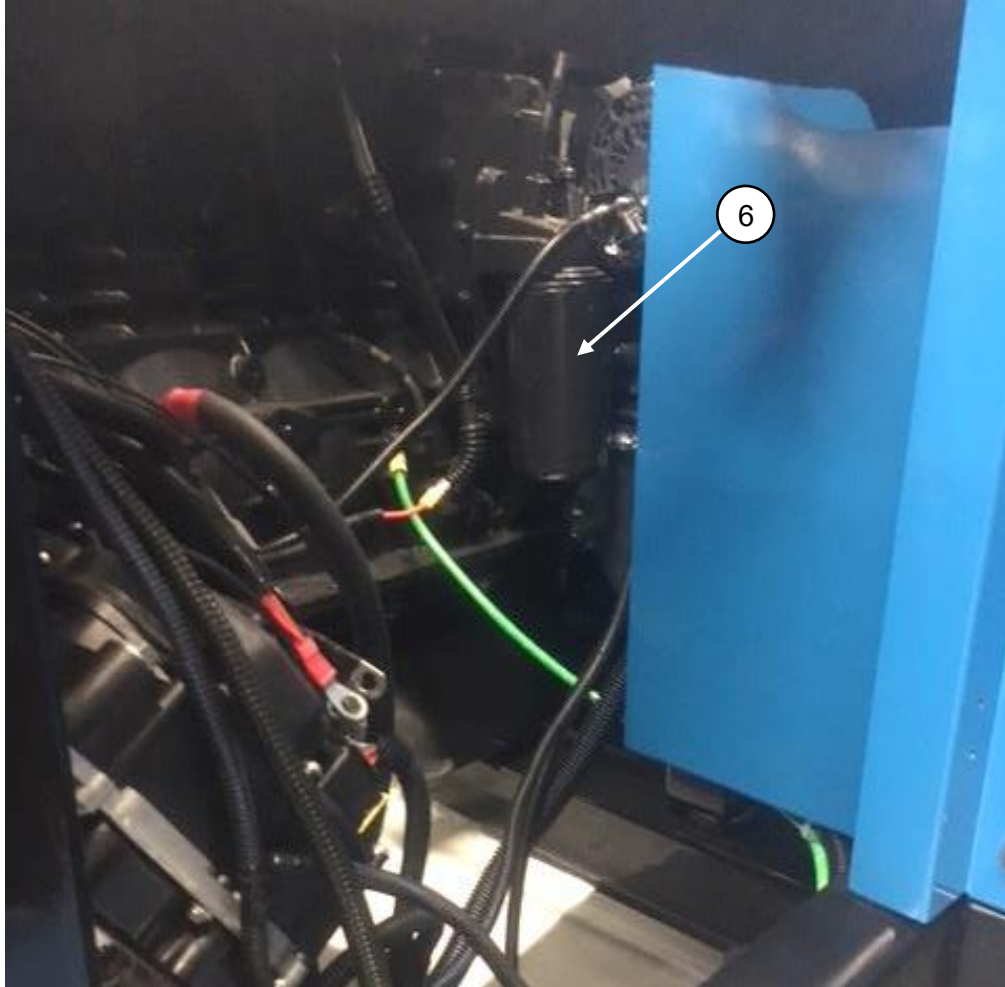

6. Oil Filter

5.3.4 Rear Controls

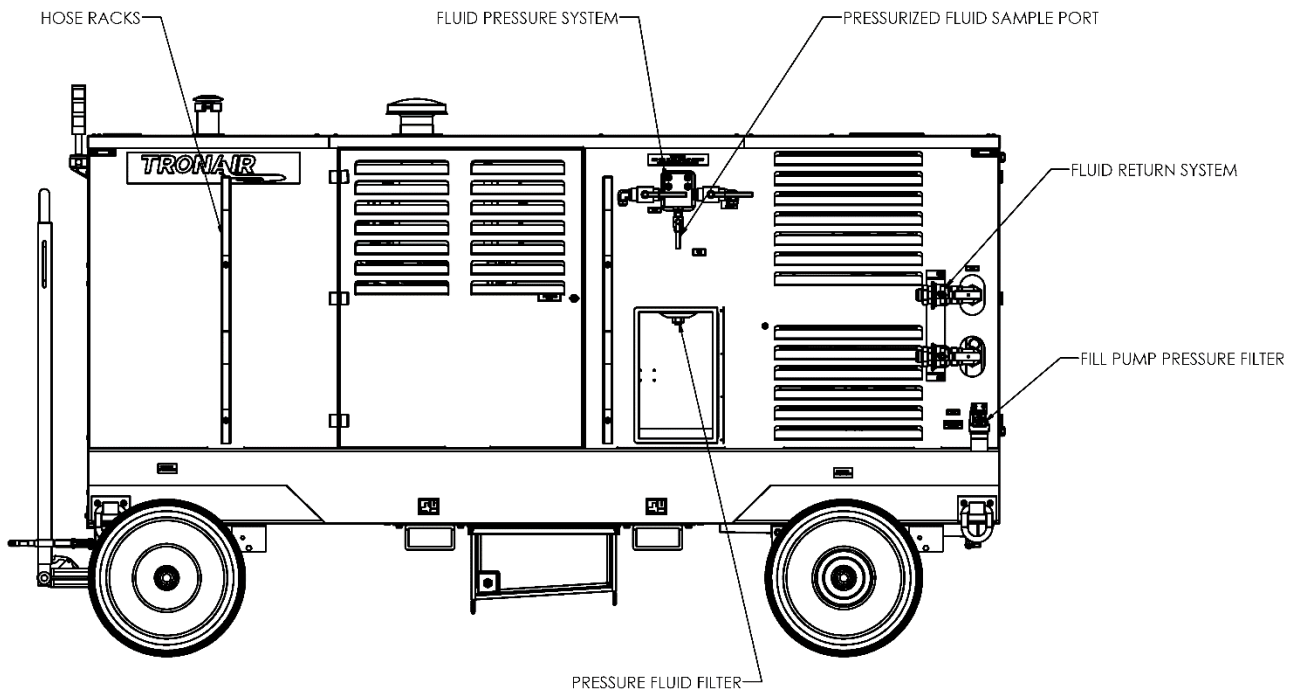
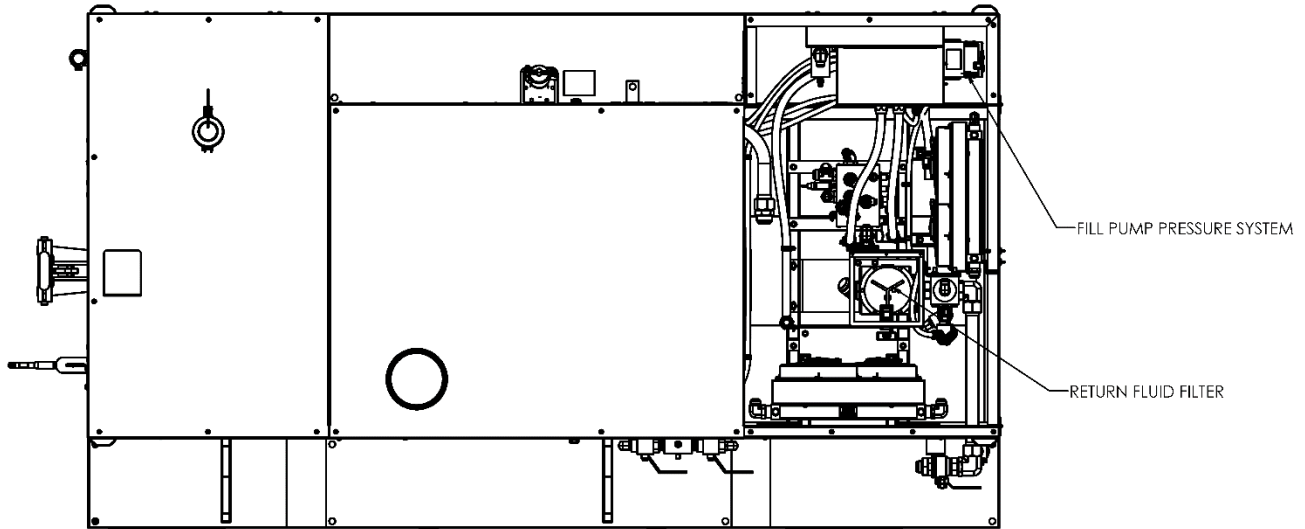

Fluid Pressure System	The source of pressurized fluid from the HPU that flows to the aircraft pressure system through the pressure hose
Fluid Return System	Fluid returning to the HPU from the aircraft that flows through the return hoses
Pressure Fluid Filter	Filters the pressurized fluid before it flows to the aircraft pressure system
Return Fluid Filter	Filters the fluid returning from the aircraft before it enters the HPU
Pressurized Fluid Sample Port	A sample valve is provided to obtain a fluid sample for analysis. In order to obtain a representative sample
Fill Pump Pressure Filter	Filters the pressurized fluid before it flows to the aircraft system
Hose Racks	Location for storing the pressure, return and fill pump hoses when not in use
Fill Pump Pressure System	A source of pressurized fluid for reservoir service. This is an independent system with a separate filter and pump

5.3.5 Split System Controls

Reference 5.7 Split System Operation.

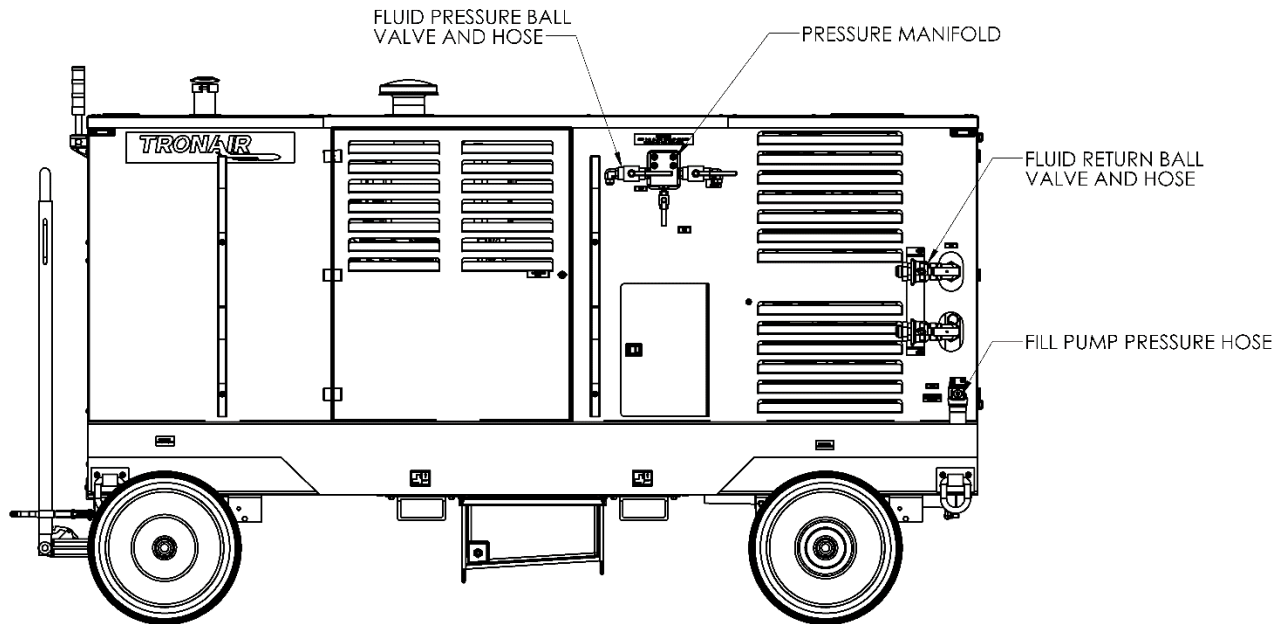

Pressure Manifold	Houses the pressure valves
Fluid Pressure Ball Valve	Used to turn on and off the flow to separate aircraft systems. Always use in either fully open or fully closed position; never use in a partially open position
Fluid Pressure Hose	Connects HPU to aircraft pressure systems
Fluid Return Hose	Connects HPU to aircraft return systems
Fluid Return Ball Valve	Used to turn on and off the flow from separate aircraft systems. Always use in either fully open or fully closed position; never use in a partially open position
Fill Pump Pressure Hose	Connects hand pump to aircraft pressure system



WARNING!

NEVER open or close split system valves without shutting off the Hydraulic Power Unit. Damage to the aircraft system or reservoir may result if either return line valve is closed while the machine is running.

5.4 HPU MODES

5.4.1 Bypass Mode

By default the HPU will start in Bypass Mode while the engine idles for 10-15 seconds before automatically switching to Parasitic Mode. Bypass Mode fluid flows internally through the unit at minimum system pressure allowing the unit to start and shut-down under no load conditions. Engaging the Stop or Emergency Stop switches will force the unit into Bypass Mode as it shuts down. Bypass Mode closes the flow path to the aircraft, isolating the HPU from the aircraft.

5.4.2 Parasitic Mode

After 10-15 seconds of running at idle, the engine runs at 1800 RPM and the unit switched into Parasitic Mode. In Parasitic Mode, fluid flows internally through the unit at an automatically set pressure and flow. Parasitic Mode keeps the engine at the correct operating temperature to prevent the Diesel Exhaust Fluid (DEF) from crystalizing. Parasitic Mode closes the flow path to the aircraft, isolating the HPU from the aircraft. The unit may alternate between Bypass Mode and Parasitic Mode to maintain the required operating temperature.

5.4.3 Aircraft Mode

Aircraft Mode closes the internal flow paths and connects the unit to the aircraft. Aircraft Mode can only be activated manually by the operator. The unit will never go in to Aircraft Mode automatically. The operator should take the unit out of Aircraft mode when pressure and flow from the HPU are not required by the aircraft.

WARNING!



Allowing the unit to remain in Aircraft Mode with no load for extended periods of time can cause the DEF fluid to crystalize, sending the unit into an inoperable fault state

5.5 START UP PROCEDURES



Rotating Parts! Keep hands, feet, hair, and clothing away from all moving parts to prevent injury. Never operate the HPU with covers, shrouds, or guards removed.



Electrical Shock! Never touch electrical wires or components while the HPU is operating. It can be a source of electrical shock.

Do not operate HPU with panels removed.

5.5.1 Initial Start Up of the HPU

1. Unit must be prepared per section 3.0 *Preparation Prior to First Use* before starting the HPU.
2. Operator must be familiar with this manual and be properly trained prior to starting the HPU.
3. Cap the pressure and return hose ends.
4. Place the reservoir selector valve in "HPU Reservoir" position.
5. The HPU battery disconnect switch must be selected to the ON position.
6. Select Power ON (1) at the control panel. This will turn on the 24 Volt DC power from the HPU battery.



CAUTION!

Both batteries must be fully charged to supply sufficient voltage for starting.

7. Push Start Switch to start the engine. Engine will idle at 1150 ± 25 rpm for 10-15 seconds before entering parasitic mode.



CAUTION!

Check that battery reads above 24 volts.

NOTE: Maintenance and Trouble Shooting are to be performed by a skilled and trained technician.

5.6 PRELIMINARY ADJUSTMENTS FOR OPERATION

The following are basic to the operation of the HPU and should be thoroughly understood.

5.6.1 Flow Control Adjustment

- a. Select "Hydraulic Power Unit" position with reservoir selector valve.
- b. Start HPU.
- c. Hold momentary flow adjustment switch.
- d. Adjust flow control using flow control knob to maximum desired flow.

5.6.2 Pressure Control Adjustment

- a. Select "Hydraulic Power Unit" position with reservoir selector valve.
- b. Start HPU.
- c. Using pressure control knob adjust for desired pressure; observing the system pressure read in psi.

NOTE: Once the flow and pressure controls have been adjusted, it is not necessary to change these settings after each operation unless desired.

5.6.3 Reservoir Selector Valve Operation

Operation of the reservoir selector valve allows the operator to select either the aircraft reservoir (closed loop) or the HPU reservoir (open loop).

CAUTION!



The reservoir selector valve should only be operated when the HPU is not running. The operation of the reservoir selector valve should be done prior to starting the HPU.

- a. Aircraft Reservoir Position (Closed Loop)
In this position, the HPU is dependent on the aircraft reservoir and system for an adequate supply of fluid. Cavitation, due to an inadequate fluid supply from the aircraft, may be indicated by erratic fluctuation of the system pressure gauge or flowmeter. At times, the aircraft fluid supply will be restricted due to small return oil lines in the aircraft. If this is a problem, decrease the flow control setting until the cavitation is eliminated.
- b. HPU Reservoir Position (Open Loop)
In this position, the HPU reservoir supplies fluid to the pump and accepts return fluid from the aircraft. It is desirable to operate the HPU in this mode since it eliminates any possibility of cavitation. Since the HPU reservoir is vented to atmosphere and the aircraft is at a higher level, it is normal for the aircraft reservoir to drain into the HPU reservoir. It is, therefore, necessary to be sure that sufficient room is available in the HPU reservoir to accommodate the additional fluid.



CAUTION!

The aircraft system reservoir must be serviced after completion of operational testing.

In the "HPU Reservoir" position, faster landing gear swings are usually possible since there is no restriction to flow at the pump inlet.

5.7 BLEEDING AIR FROM SYSTEM

Rapid fluctuations of the pressure and flow-meter are indications of cavitation or entrapped air in the hydraulic lines and/or components. Air may enter the system when:

- Changing a component on the aircraft.
- Changing hose connections and/or couplings.

5.7.1 To Easily Purge the Unit of Air

- a. Fill reservoir to recommended level.
- b. Place reservoir selector valve in "Hydraulic Power Unit" position.

NOTE: If fluid is not flowing, shut off HPU and reference 8.2 No Flow in Trouble Shooting section

- c. Run unit for five (5) minutes and shut off.
- d. If additional bleeding is required, connect the pressure and return hoses together and open all pressure and return ball valves at the rear of the HPU. Place the unit in HPU mode and start the unit (**system pressure should remain under 550 psi (approximately 38 bar)**). Allow fluid to flow at full flow for five (5) minutes, then shut the HPU off.



WARNING!

Failure to open the return ball valves will cause hose or valve rupture. Property damage and personal injury can result.

5.8 SPLIT SYSTEM OPERATION

The split system allows control of fluid flow to aircraft with two hydraulic systems. The systems consist of two sets of hoses and valves located in the pressure and return systems. The valves are mounted on the side of the hydraulic power unit and are of the 90° ball type. The valves are open when the operating handle is in line with the valve.

Although both systems may be operated simultaneously, usually only one system is required at any one time. If both valve sets are open simultaneously, the pump output will be divided between the two systems. Also, cross flow between aircraft reservoirs may occur if a reservoir level or pressure differential exists. Select valve positions prior to starting machine.

5.8.1 To Operate the Split System

- a. Before starting machine, open pressure and return valves of the same system.



WARNING!

Ensure pressure and return hoses of the same system are paired and used together.

- b. After completing tests on one system, shut the machine off before selecting the second system.



WARNING!

NEVER open or close split system valves without shutting off the Hydraulic Power Unit. Damage to the aircraft system or reservoir may result if either return line valve is closed while the machine is running.

5.9 ELECTRIC FILL PUMP OPERATION

The Electric Fill Pump allows for filling the aircraft reservoir. The electric fill pump circuit is separate from the main hydraulic system; a separate filter and hose are attached to the back panel of the HPU.

To operate the pump, connect the external hose to the aircraft reservoir fill port, and hold down the electric fill pump switch located on the center electrical control panel. An indicating light will illuminate if the fill pump motor is running. Observe the fill system pressure on the fill pump pressure gauge.

5.10 SAMPLE VALVE

A sample valve is provided on the side of the unit to obtain a fluid sample for analysis or inspection.

Run the unit for 5 minutes and shutdown before taking fluid samples.



Pressurized Fluid! Before servicing the HPU or equipment, ALWAYS shut down the unit to relieve any residual pressure in the hydraulic system. Turn the battery disconnect switch to Off.

5.11 EMERGENCY SHUT DOWN PROCEDURE

In the event an emergency shutdown is necessary, press the emergency stop switch located on the electrical panel.

5.12 DESCRIPTION OF ALARM SYSTEMS

5.12.1 High Fluid Temperature Fault

The warning for high fluid temperature is an active fault that will display on the screen when the return fluid temperature is 160° F (71° C) or above. The HPU will shut down if the temperature reaches this point. The HPU can be re-started when the fluid has cooled sufficiently.

If the high temperature fault is triggered reference section 9.0 Trouble Shooting.

5.12.2 High and Low Reservoir Level Fault

The warning for high and low reservoir level will display on the screen when the reservoir fluid level is either above the maximum level or below the minimum level. The HPU will shut down if either of the warnings is engaged.

5.12.3 Clogged Filter Warning

The warning for the clogged filter will display on the screen if the pressure filter element becomes clogged or is in need of replacement. The HPU will not shut down if the warning is engaged.

If the clogged filter warning is active, the pressure filter element requires changing. Reference section 9.13.11 Electric Filter Clogging Indicator for maintenance procedure.

NOTE: Maintenance and Trouble Shooting are to be performed by a skilled and trained technician.

5.12.4 Red Stop Fault Light

The red fault light turns on when a fault has been detected or when Approaching Engine Protection Shutdown Limits.

5.12.5 Yellow Warning Light

The yellow warning light turns on when a warning has been detected.

5.13 INFREQUENT HPU USE

If the unit is not used frequently Tronair recommends operating the unit monthly. Operating regularly assures that the seals are kept lubricated, eliminates air pockets in the system, reduces moisture in the fluid and helps extend the hose life.

5.13.1 Infrequent HPU Use Start Up Procedure

1. Assure that the HPU reservoir is filled between the minimum and maximum level
2. Verify the unit has sufficient fuel to operate for one hour
3. If unit is equipped with a run around kit, connect the pressure and return hoses together
4. Place the reservoir selector valve in "HPU Reservoir" position
5. Open the return ball valves on the back of the unit
6. Pressure ball valves
 - a. If unit **IS** equipped with a runaround kit **ensure the hoses are connected to each other**, open the pressure ball valves on the back of the unit
 - b. If the hoses **are not connected to each other**, close the pressure ball valves on the back of the unit
7. Verify the return ball valves on the back of the unit are open
8. Fully open the bypass valve
9. Adjust the pressure control to the minimum setting (CCW)
10. Start the unit
11. Set flow to ½ the maximum flow capacity of the unit. You may need to increase the pressure adjustment to achieve flow.
12. Bypass valve
 - a. If unit **IS** equipped with a runaround kit **ensure the hoses are connected to each other**, fully close the bypass valve
 - b. If the hoses **are not connected to each other**, leave the bypass valve fully open
13. Operate the unit for 15-30 minutes in this condition. Fluid temperature should reach 100°-130° F (37.8°-54.4° C)
14. At the completion of the 15-30 minute circulation run, open the bypass valve and shut off the unit
15. Place the selector valve in the Aircraft Reservoir position
16. Close the pressure and return ball valves on the back of the unit

6.0 PACKAGING AND STORAGE

6.1 PACKAGING REQUIREMENTS

- a. Drain hydraulic fluid until level is below the minimum fluid level indicator.
- b. Block up the unit on a pallet so the wheels are not touching the pallet or shipping container.
- c. Plug all hose ends.
- d. Strap unit to pallet or shipping container using the tie down rings located on the frame bottom.

NOTE: Use at least four (4) straps with a minimum 10,000 lb (4,536 kg) capacity each.

6.2 HANDLING

The unit can be lifted by means of a fork truck from the center of the machine.

NOTE: Be sure the forks are long enough to reach the frame cross members for stability during lifting. Use the dedicated forklift tubes.

6.3 PACKAGING PROTECTION

No special packaging material for cushioning or suspension is required.

6.4 LABELING OF PACKAGING

Packaging should be labeled as follows:

**DO NOT DROP
THIS SIDE UP
DO NOT STACK**



6.5 STORAGE COMPATIBILITY

No special considerations for short term storage (less than three months).

6.6 STORAGE ENVIRONMENT

Cover HPU with a suitable, non-abrasive tarp if storing outside. For storage periods greater than three months, drain hydraulic fluid from all hoses and the reservoir. Cover unit to protect outside surface.

If storing outside, protect unit from freezing water, sand, dirt, and direct sunlight. A cover is highly recommended.

6.7 STORAGE SPACE AND HANDLING FACILITIES

Weight (Dry) 10,000 lbs (4536 kg)
Length 156.5 in (397.5 cm)
Width 83.5 in (212 cm)
Height 95.25 in (242 cm)

7.0 TRANSPORTATION

- 1. Do not stack Hydraulic Power Units.
- 2. The unit can be lifted by means of a fork truck from the center of the HPU.

NOTE: Be sure the forks are long enough to reach frame cross members for stability during lifting. Use the dedicated forklift tubes.

8.0 SERVICING

As with all Ground Support Equipment it is very important to provide proper preventative maintenance and service. This will increase the service life of the diesel engine, which can be expected to operate for 30,000 hours without a major overhaul (this may vary according to local operating conditions.) The following specifies consumable service requirements:

Fuel: Ensure that the correct diesel fuel ASTM D 975 is used.

Engine Oil: 10W-30 (CJ-4) is suitable for most operating temperatures. However, lower viscosity oils can be used to aid starting at temperatures below -5° C (23° F). Refer to engine Operation and Maintenance Manual (provided as a supplement to this manual) for oil and viscosity recommendations. Must meet ASTM D3306-00A Standard.

CAUTION!



Do not over fill the engine as damage may occur. Always use the engine oil level dipstick to ensure the correct level. Always use the same brand of engine oil. When topping up the oil level always prevent dirt from entering by cleaning around the oil filler prior to filling. The engine oil level should be checked every 10 hours of operation.

Cooling System: Use 50/50 ethylene glycol mixture for temperatures above -36° C (-33° F). Refer to engine Operation and Maintenance Manual (provided as a supplement to this manual) for anti-freeze and water quality recommendations.

Filters: Fuel lubricity filter Change every 500 hours or 6 months
Engine oil filter..... Change every 500 hours or 6 months with oil change
Air cleaner filter Check daily. Change when clog indicator shows clogged
Hydraulic Pressure Filter Change every 25 hours or annually
Hydraulic Return Filter Change every 25 hours or annually
Hydraulic Hand Pump Filter Change every 25 hours or annually

8.1 GENERAL (DAILY CHECKS)

1. Unit..... Visually inspect outside of HPU for loose hardware, loose parts, frayed wires/cables and general appearance.
2. Radiator..... Open radiator access door and remove radiator cap (cold only). Ensure that coolant is up to the bottom of the fill neck. Service as required.
3. Engine Hoses Check integrity of hoses and clamps for tightness.
4. Fuel Level..... Turn power on and check fuel level. Top up as required with fuel.
5. Engine Inspect all fuel lines and fittings for traces of fuel leakage. Visually inspect cylinder block oil pan and valve covers for oil leakage.
6. Oil Level Remove dipstick to ensure oil level is at full mark. Replenish as required.
7. Fan Belt..... Check belt for correct tension. Look for wear.
8. Air Intake Filter Ensure that plugged filter indicator shows clean, if not, replace air filter. Check again once unit is running.
9. Doors..... Check that all doors are securely latched before driving or starting

8.2 SHORT TERM PREVENTIVE MAINTENANCE SCHEDULE

It is recommended to change the engine oil and filter after the first 50 hours of operation.

The table on the following page is provided as a guide to for frequent service intervals. The engine Operation and Maintenance Manual (provided as a supplement to this manual) provides engine service interval information for daily, 250 hour, 500 hour, 1000 hour and 2000 hour intervals. See the engine Operation and Maintenance Manual.

8.2 SHORT TERM PREVENTIVE MAINTENANCE SCHEDULE (continued)

INSPECTION AND SERVICE SCHEDULE (HOURS)

COMPONENT	Daily	250	500	6 Months	25 hrs or Annually
ENGINE OIL					
Check Level	X				
Change Oil			X	X	
Change Filter			X	X	
Check Oil Pressure				X	
COOLANT					
Inspect Hoses and Clamps	X				
Check Level (Cold)	X				
Inspect Fan Belt	X				
Check Coolant Concentration		X	X	X	
Flush and Change Coolant			2000		
FUEL					
Change Lubricity Filter			X	X	
Change Fuel Filter			X	X	
Check Fuel Level	X				
Inspect Hoses and Clamps	X			X	
Inspect for Leaks	X			X	
Drain Water Separator	X				
EXHAUST					
Inspect	X				
Tighten Clamps		X		X	
AIR INTAKE					
Inspect Hoses and Clamps	X				
24 VDC					
Check Battery Fluid (If Applicable)			X	X	
Check Battery Terminals	X			X	
CHASSIS					
Check for Loose Hardware	X			X	
INSTRUMENT PANEL					
Inspect Switches			X	X	
Calibration			X	X	
HYDRAULIC FILTERS					
Pressure					X
Return					X
Hand Pump					X

9.0 TROUBLE SHOOTING

The following is a guide to solutions of common problems associated with the HPU. See related Appendix for Hydraulic and Electrical Schematics.

If the problem is not resolved using the trouble shooting information, call the manufacturer for Technical Assistance (See Section **1.3 Manufacturer**).

NOTE: Maintenance and Trouble Shooting are to be performed by a skilled and trained Technician.

9.1 HPU WILL NOT START

Possible Cause	Solution
Reservoir fluid level is too high or too low	Fill the reservoir above the Minimum Fluid Level to extinguish the Low Level fault. Drain fluid below the Maximum Fluid Level to extinguish the High Level fault.
High return fluid temperature	Allow the hydraulic fluid to cool until the fault goes out. Refer to <i>Section 9.5 for Over-heated Causes</i> .
No Fuel	Add fuel to unit

9.2 NO FLOW

Possible Cause	Solution
Flow control set too low	Increase flow setting.
Flow path does not exist	A flow path (such as a moving actuator or an open circuit) must exist for flow to be present. When system pressure exceeds the compensator control setting, or when the system no longer requires flow, the control de-strokes the pump while maintaining the preset pressure.

NOTE: Under some conditions where a large amount of air has entered the system, the pump may not be able to draw an initial prime. If this occurs, loosen the inlet hose near the pump and allow air to escape. Re-tighten the hose when fluid appears.

9.3 REDUCED FLOW

Possible Cause	Solution
Flow control is set too low	Increase flow setting.
Pressure adjustment is set too low	Slightly increase pressure setting.
Pressure compensator control is reducing pump output.	When system pressure exceeds the compensator control setting, or when the system no longer requires flow, the control de-strokes the pump while maintaining the preset pressure.

9.4 NO PRESSURE or REDUCED PRESSURE

Possible Cause	Solution
Pressure adjustment is set too low	Increase pressure adjustment.
Flow path is open	Pressure is resistance to flow. The HPU will reach full pressure as flow paths (such as moving actuators and open valves) are closed.

9.5 FLUID OVERHEATS

Possible Cause	Solution
Fan is not functioning properly	Check the cooler fan output. Forced air should be easily detected at the inside of the heat exchanger fan. Check the circuit breaker for the fan motor.
Rear ball valve is being used in a partially closed position	All ball valves must be used in a fully open or fully closed position. These valves are not intended for metering flow. All flow adjustments must be made using the pump flow control.

9.6 ELECTRIC PUMP IS NOT PUMPING FLUID

Possible Cause	Solution
No flow	Check fuses on the fill pump motor
Not filling reservoir	Check the coupling connection or remove aircraft reservoir pressure
Low flow	Change the electric fill filter element

10.0 MAINTENANCE

If the unit is not used frequently Tronair recommends operating the unit monthly. Operating regularly assures that the seals are kept lubricated, eliminates air pockets in the system, reduces moisture in the fluid and helps extend the hose life. If the unit is not used frequently see 5.13 Infrequent Use Procedure.

10.1 GENERAL (Daily Checks)

1. Unit..... Visually inspect outside of HPU for loose hardware, loose parts, frayed wires/cables and general appearance.
2. Radiator..... Open radiator access door and remove radiator cap (cold only). Ensure that coolant is up to the bottom of the fill neck. Service as required.
3. Engine Hoses..... Check integrity of hoses and clamps for tightness.
4. Fuel Level..... Turn power on and check fuel level. Top up as required with fuel.
5. Def Level..... Turn power on and check Def level. Top up as required.
6. Engine..... Inspect all fuel lines and fittings for traces of fuel leakage. Visually inspect cylinder block oil pan and valve covers for oil leakage.
7. Oil Level..... Remove dipstick to ensure oil level is at full mark. Replenish as required.
8. Fan Belt..... Check belt for correct tension. Look for wear.
9. Air Intake Filter..... Ensure that plugged filter indicator shows clean, if not, replace air filter. Check again once unit is running.
10. Doors..... Check that both doors are securely latched before driving or starting

10.2 FILTERS

NOTE: The lubricity fuel filter plays a dual role in filtering the fuel and adding a lubricant. Change the filter every 500 hours of running time or every six months. To change filter loosen filter first and then remove filter assemble from mounting bracket. To drain engine oil move lever on oil drain valve down.



1



2



3

Item	Part Number	Description	Qty
1	H-4207	Lubricity Filter	1
2	H-4208	Fuel Filter	1
3	H-4209	Oil Filter	1

10.3 ENGINE COMPONENTS

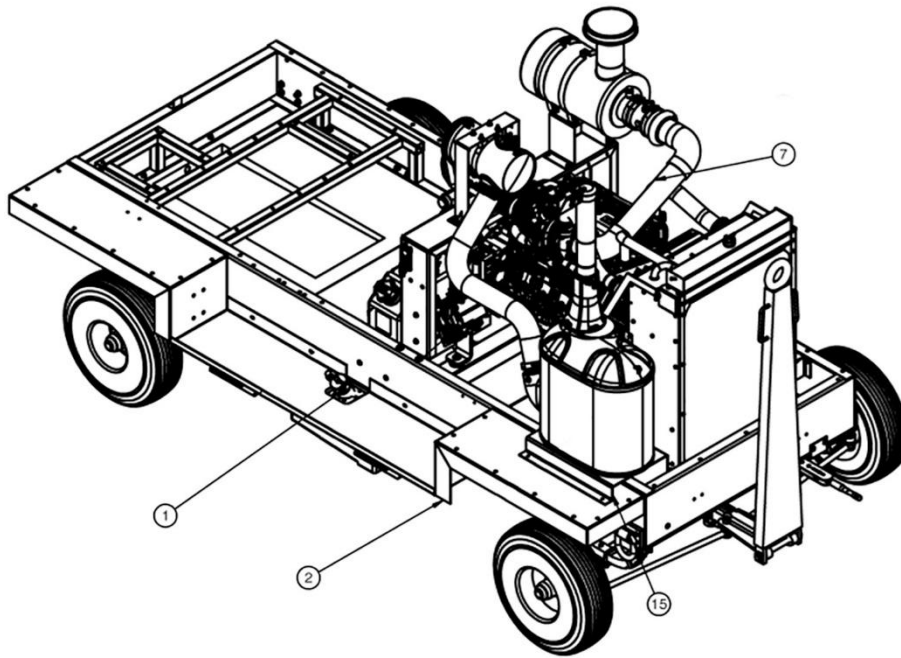
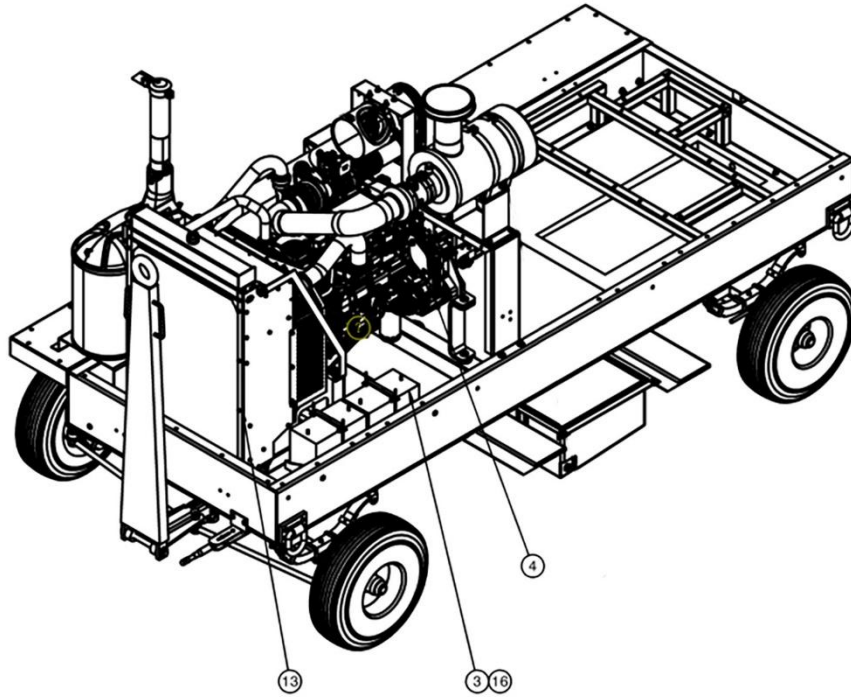

Parts List

Item	Part Number	Description	Qty
1	Z-9325	ASSEMBLY, FUEL TANK	1
2	S-3173-01	TRAY, CONTROLS SIDE	1
3	EC-3149	BATTERY, 12 VOLT	2
4	Z-9308	ASSEMBLY, PUMP/ENGINE	1
7	TR394-01-018.50	TBG, SST 4.00D-.120W	1
15	S-3169-01	BRACKET, SCR (P)	1
16	H-4005	TIE-DOWN, BATTERY	2
13	H-4047	ENGINE, FPT 151KW; consists of:	1

10.4 HYDRAULIC PUMP

The hydraulic pump does not require regular maintenance. Under normal operating conditions, the pump will perform for thousands of hours of use without rebuilding. See **Appendix – Oilgear Pump Manual** for further details.

10.4.1 Hydraulic Pump Replacement Parts

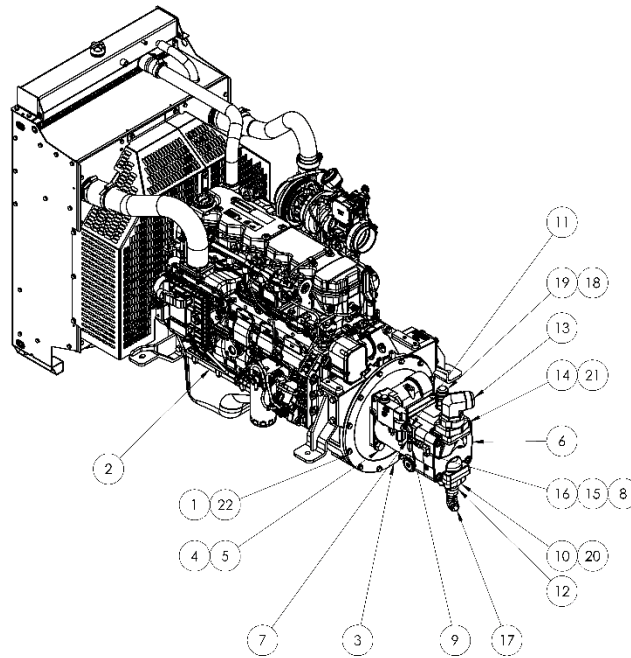

Parts List

Fluid Type: Aviation Phosphate Ester, Type IV, V

Item	Part Number	Description	Qty
1	G-1513-1070N	FLATWASHER, 3/8 THRU HARDENED	12
2	H-4047	ENGINE	1
4	G-1513-1110N	FLATWASHER, 3/4 NARROW THRU HARDENED	4
5	G-1420-111016	BOLT, 3/4-16 x 1.75 HEX HD GR 8	4
6	HC-2752-00	PUMP, HYDRAULIC (PE)	1
7	N-2016-05-S	TEE, RUN SWIVEL NUT	1
8	N-2924-08	CONNECTOR, IN-LINE ORIFICE	1
9	N-2055-01-S	REDUCER, TUBE	1
10	N-2664-03-S-E	KIT, FLANGE (PE)	1
11	N-2001-08-S-E	ELBOW, STRAIGHT THREAD	1
12	N-2932-05-S-E	CONNECTOR, FLANGE 16-20	1
13	N-2001-33-S-E	ELBOW, STRAIGHT THREAD	1
14	N-3034	ANCHOR, FLANGE (32-40)	1
15	N-2052-07	EXPANDER, TUBE	1
16	N-2002-06-S	ELBOW, 90°, -08 M JIC X -08 F JIC	1
17	N-2002-10-S	ELBOW, SWIVEL NUT	1
18	N-2007-24-S-E	ELBOW, STRAIGHT THREAD	1
19	N-2052-04	EXPANDER, TUBE	1
20	HC-2006-222	O-RING, SERIES 2	1
21	HC-2006-232	O-RING, SERIES 2	1
22	G-1533-100035	BOLT M10-1.5 X 35mm LG. CLASS 10.9	12

10.6.1 Pressure Filter Element

Replace the filter element any time the clogged filter indicator light is triggered.

Replace the filter element annually to ensure proper cleanliness of the hydraulic system. This is a minimum requirement.

Standard filter changes depend on how frequently the HPU is used and the cleanliness of the fluid, along with the environment to which the HPU is exposed. Periodic fluid analysis is recommended to properly determine the optimum frequency of filter element changes.

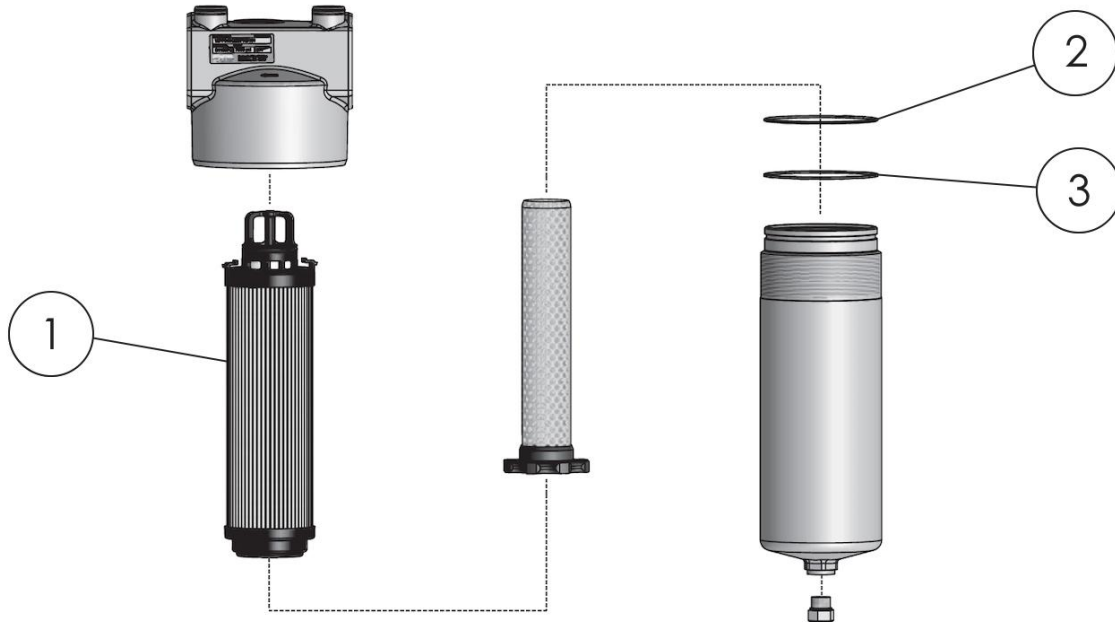

Parts List

Fluid Type: Aviation Phosphate Ester, Type IV, V

Item	Part Number	Description	Qty
	K-5754	KIT, FILTER REPLACEMENT; consists of:	
1	HC-3027	FILTER ELEMENT	1
2	HC-3029	O-RING	1
3	HC-3031	ANTI- EXTRUSION RING	1

10.6.2 Return Filter Element

Replace the return filter element at the same time the pressure filter element is being replaced.

TO ACCESS FILTER ELEMENT,
 REMOVE TOP OF FILTER
 BODY. HANDLE TORQUE
 IS TO BE HAND TIGHT.

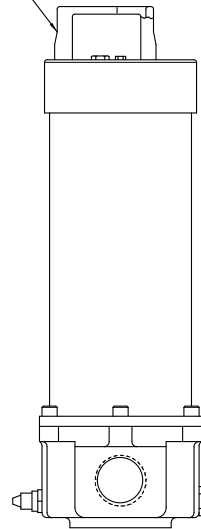

Parts List

Fluid Type: Aviation Phosphate Ester, Type IV, V

Item	Part Number	Description	Qty
Not Shown	HC-2006-257	O-ring (Bowl)	1
Not Shown	◆ K-3587	Kit, Replacement Filter Element	1

◆ **HC-2006-257 O-ring is included in Kit.**

10.6.3 Fill Pump Filter Element

Replacement of the hand pump filter element is dictated by frequency of use and the cleanliness of the fluid, along with the environment to which the HPU is exposed. Changing the hand pump filter element at the same time as the pressure filter element will ensure a regular maintenance schedule.

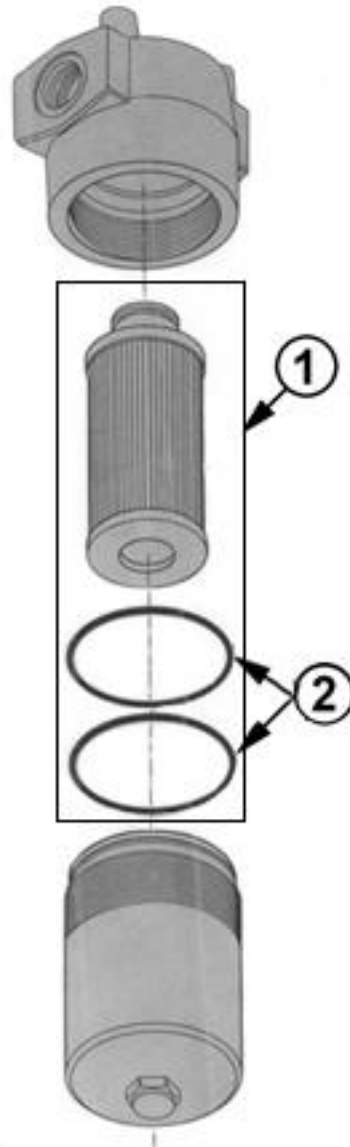

Parts List

Fluid Type: Aviation Phosphate Ester, Type IV, V

Item	Part Number	Description	Qty
1	K-3752	Kit, Replacement Filter Element	1
2	E82142	O-ring and Backup Ring	2

10.6.4 Desiccant Air Filter

Replace the desiccant/air filter whenever the material inside the element is pink or reddish in color (see Element Label for details).

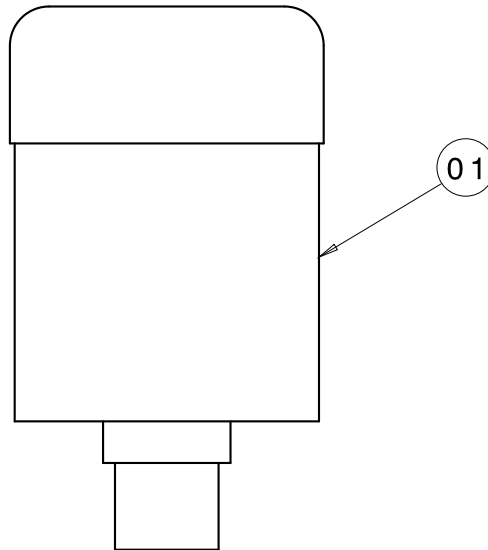

Parts List

Fluid Type: Aviation Phosphate Ester, Type IV, V

Item	Part Number	Description	Qty
1	HC-1763	Filter Element	

10.6.5 Pressure Filter Assembly with Electric Filter Clogging Indicator

The Electric Filter Clogging Indicator does not require regular general maintenance. The panel light will illuminate when the clogging indicator senses a 98 psi differential pressure across the filter element. Installing a new filter element will eliminate the clogged condition.

NOTE: Higher flow rates will result in higher differential pressures. (Example: The clogging indicator may sense a 98 psi differential pressure at a high flow rate but not show a clogged condition when the flow rate is reduced to 10 gpm)

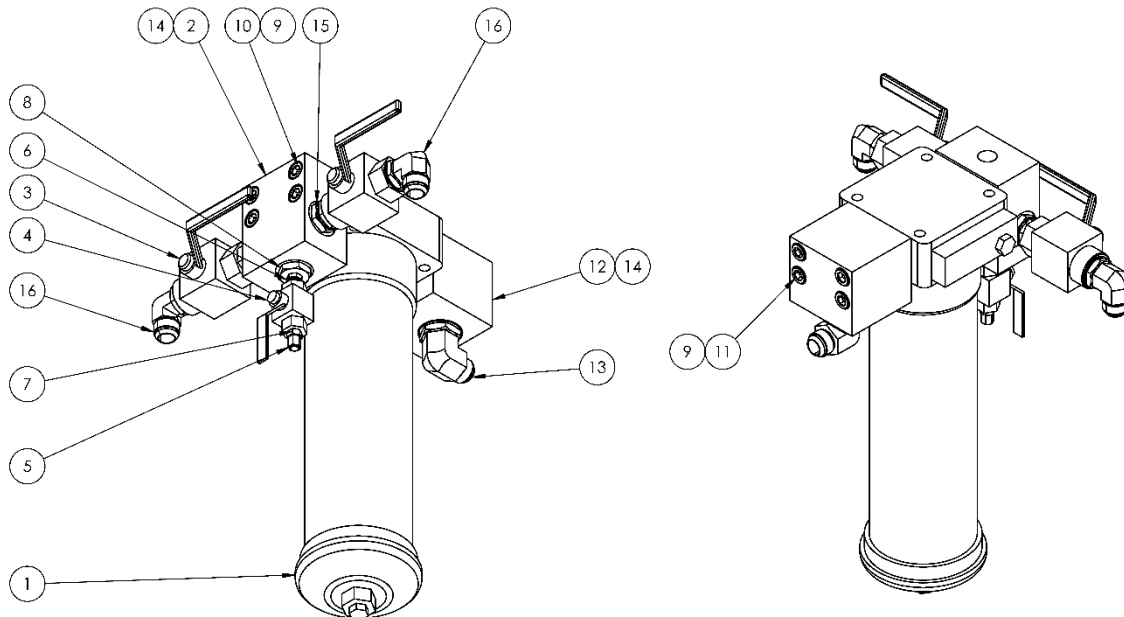

Parts List

Fluid Type: Aviation Phosphate Ester, Type IV, V

Item	Part Number	Description	Qty
1	HC-3025	FILTER, PRESSURE	1
2	HC-2754	MANIFOLD, PRESSURE	1
3	HC-1771-05	VALVE, BALL	2
4	HC-1771-02	VALVE, BALL	1
5	N-2008-03-S	CAP #4	1
6	N-2464-05-S-E	UNION, #6 SAE STR THD	1
7	N-2007-05-S-E	CONNECTOR, STR THD	1
8	N-2463-31-S-E	FITTING, REDUCER-EXPANDER (16-6)	1
9	G-1626-M16Z	LOCKWASHER, M16 HI-COLLAR	8
10	G-1151-110234	SCREW, 5/8-11 X 3-1/2" SOCKET HD CAP	4
11	G-1491-111050	SHCS, M16 X 2 X 120, CLASS 12.9	4
12	HC-2106	FLANGE, SAE STR THRD ELBOW	1
13	N-2973-S-E	ELBOW, STRAIGHT THREAD	1
14	HC-2006-225	O-RING, SERIES 2	2
15	N-2464-10-S-E	UNION, #16 SAE STR THD	2
16	N-2001-24-S-E	ELBOW, STRAIGHT THREAD	2

10.6.6 Return Filter and Manifold Assembly

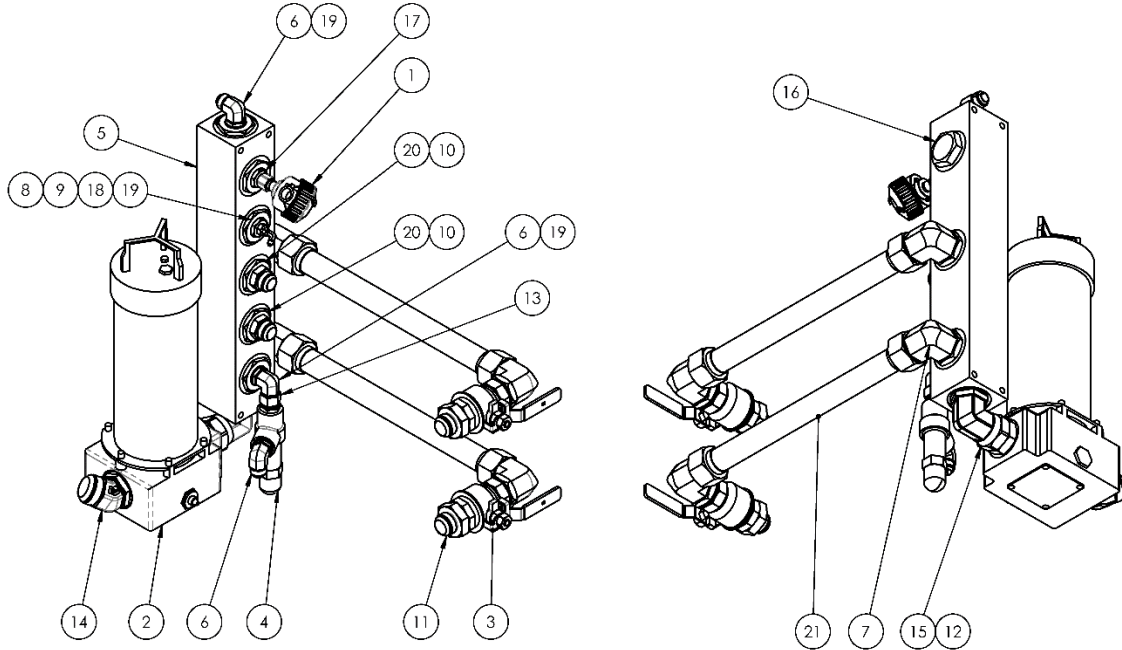

Parts List

Fluid Type: Aviation Phosphate Ester, Type IV, V

Item	Part Number	Description	Qty
1	H-4047 RTD	SENSOR, RTD	1
2	HC-2052	FILTER, RETURN (PE)	1
3	HC-2058-03	VALVE, BALL	2
4	HC-2202	VALVE, PRESSURE RELIEF, PRESET	1
5	HC-2755	MANIFOLD, RETURN	1
6	N-2001-24-S-E	ELBOW, STRAIGHT THREAD	3
7	N-2001-33-S-E	ELBOW, STRAIGHT THREAD	4
8	N-2002-03-S	ELBOW, SWIVEL NUT	1
9	N-2007-06-S-E	CONNECTOR, STRAIGHT THREAD	1
10	N-2007-28-S-E	CONNECTOR, STRAIGHT THREAD	2
11	N-2007-32-S-E	CONNECTOR, STRAIGHT THREAD	2
12	N-2007-33-S-E	CONNECTOR, STRAIGHT THREAD	1
13	N-2036-10-S-E	SWIVEL, 37° FEMALE	1
14	N-2042-15-S-E	ELBOW, 45° STRAIGHT THREAD	1
15	N-2049-32-S-E	ELBOW, 90° SWIVEL	1
16	N-2053-13-S-E	PLUG, HEX HD W/ O-RING	1
14	N-2202-13-S-E	ADAPTER, #16 SAE X 1/2 FPT	1
18	N-2463-16-S-E	FITTING, REDUCER/EXPANDER	1
19	N-2463-26-S-E	FITTING, REDUCER/EXPANDER	4
20	N-2463-27-S-E	FITTING, REDUCER/EXPANDER	2
21	Z-9432	ASSEMBLY, RETURN TUBE	2

10.7 HYDRAULIC HOSES

Hoses used on the HPU must be periodically inspected for damage, blisters, leaks, or hose end problems. Any damaged or defective hose should be replaced as soon as possible.

Hoses used on Aviation Phosphate Ester units have a shorter useful life than hoses used on Mineral Base units. Surface moisture is normal with Aviation Phosphate Ester hoses as long as the fluid does not form into drops.

Parts List

Fluid Type: Aviation Phosphate Ester, Type IV, V

Item	From	To	Hose
28	CONTROL MANIFOLD	PRESSURE FILTER	TF-1117-38-59.5
29	PUMP LOAD SENSE	PROP PRV	TF-1041-05-65.0
30	PUMP - ORFICE FITTING	FLOW CONTROL	TF-1195-02-92.0
31	FLOWCONTROL	CONTROL MANIFOLD	TF-1117-38-22.5
32	FLOWMETER	FLOWCONTROL	TF-1117-38-30.0
33	PUMP OUTLET	CONTROL MANIFOLD	TF-1117-38-70.0
34	CASE COOLER	RETURN MANIFOLD	TF-1041-01-43.8
35	PUMP CASE	CASE COOLER	TF-1041-68-121
36	FILL PUMP	FILL FILTER	TF-1040-02-96.0
37	FILL PUMP (RELIEF)	RESERVOIR	TF-1041-05-61.0
38	RESERVOIR	FILL PUMP	TF-1041-09*44.0
39	RETURN FILTER	SELECTOR VALVE	TF-1041-18-27.3
40	RETURN RELIEF	RESERVOIR	TF-1041-01-50.0
41	PARA COOLER LOWER	RETURN MANIFOLD	TF-1041-54-17.0
42	PARA COOLER UPPER	RETURN MANIFOLD	TF-1041-03-32.0
43	CONTROL MANIFOLD TEE	PARA COOLER LOWER	TF-1041-03-55.0
44	CONTROL MANIFOLD TEE	PARA COOLER UPPER	TF-1041-03-38.5
45	CONTROL MANIFOLD "LS OUT"	RETURN MANIFOLD	TF-1041-05*48.0
46	SELECTOR VALVE	PUMP	TF-1117-41-21.0

10.8 FUEL TANK

The Fuel Tank does not require regular general maintenance.

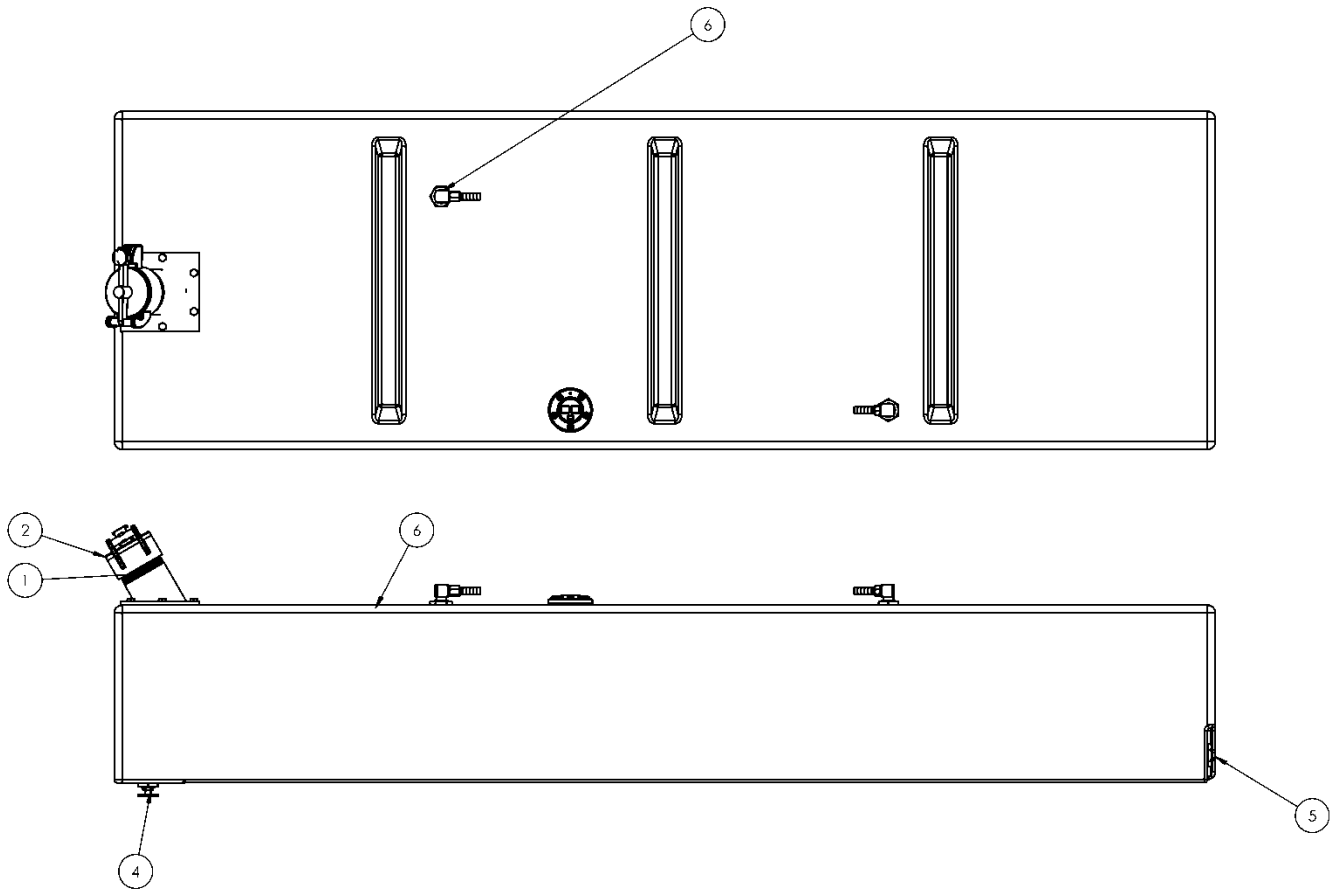

Parts List

Fluid Type: Aviation Phosphate Ester, Type IV, V

Item	Part Number	Description	Qty
1	Z-7756	WELDMENT, FUEL NECK	1
2	15253	FILL CAP LESS SCREEN (GREEN)	1
3	G-1112-105010	BOLT, 1/4-20 X 1.0" LG SST HEX HD	6
4	N-2206-03-SS	PLUG, HEX HEAD	1
5	N-2783-02	DRAIN, COCKS	1
6	H-4052	TANK, FUEL (70 GAL)	1

10.9 CONTROL PANEL

Annual calibration of instrumentation is recommended. See Section **12.0 – Calibration of Instrumentation** for details of calibration.

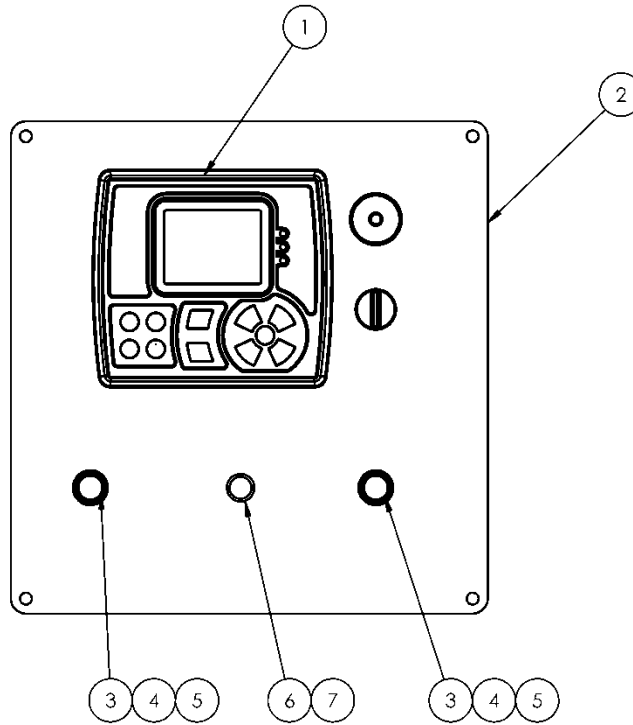

Parts List

Fluid Type: Aviation Phosphate Ester, Type IV, V

Item	Part Number	Description	Qty
1	EC-3441-HPU	HARNESS, WIRING (695A)	1
2	S-3162-01	PANEL, CONTROLS (P)	1
3	EC-2344	PUSH BUTTON, ILLUMINATED/FLUSH	2
4	14142	FLANGE, LATCH	2
5	14143	BLOCK, CONTACT (GREEN)	2
6	EC-3051	KNOB, 1/4" SHAFT	1
7	EC-3059	POTENTIOMETER, 10KOHM 10 TURN	1

10.10 CONTROL BLOCK ASSEMBLY

10.10.1 Control Manifold Assembly

Annual calibration of instrumentation is recommended. See Section **12.0 – Calibration of Instrumentation** for details of calibration.

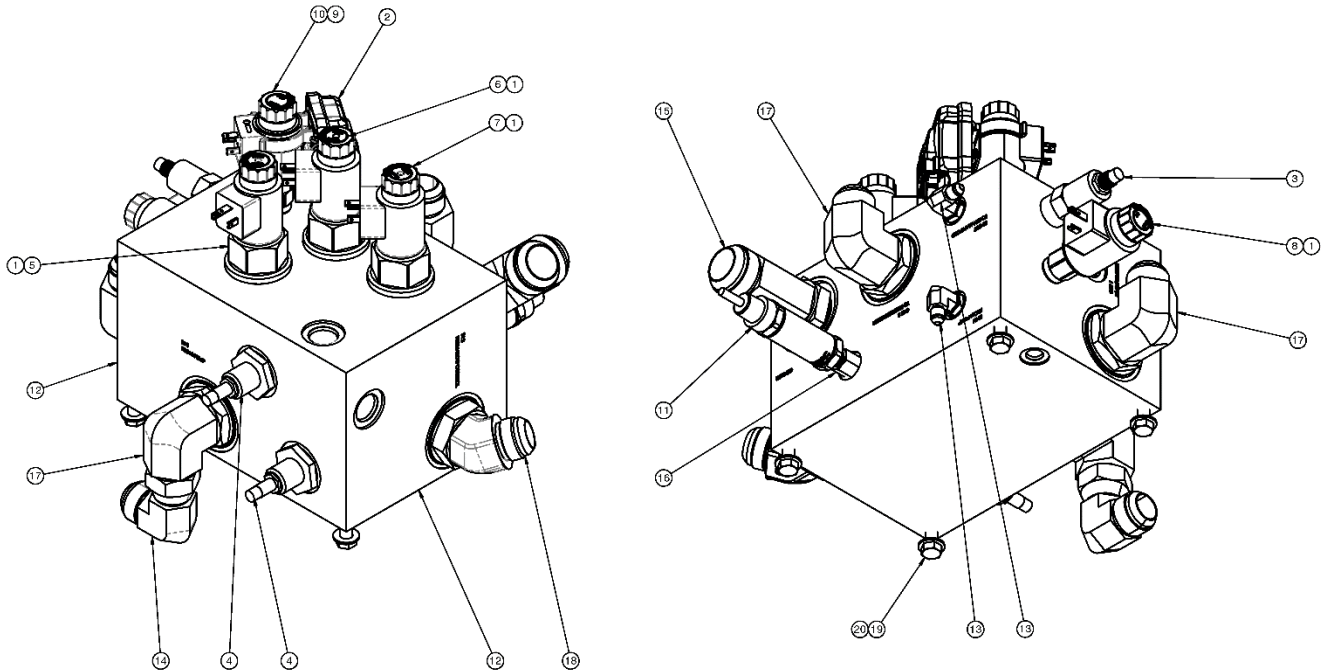

Parts List

Fluid Type: Aviation Phosphate Ester, Type IV, V

Item	Part Number	Description	Qty
1	EC-3032	COIL, 24VDC DIN	4
2	EC-3509	24VDC COIL W/TVS DIOSE, XMD-01	1
3	HC-1452	VALVE, PRESS. RELIEF (PE)	1
4	HC-1772	VALVE, PRES. RELIEF (PE)	2
5	HC-2767	VALVE, 2-WAY POPPET	3
6	HC-2768	VALVE, 2-WAY N.C. SOFT SHIFT	1
7	HC-2769	VALVE, 2-WAY N.O. SOFT SHIFT	2
8	HC-2770	VALVE, 2-WAY N.O. POPPET	1
9	HC-2771	VALVE, PILOT OPERATED RELIEF	1
10	HC-2772	VLVE, ELEC-PROPORTIONAL RELIEF	1
11	EC-3514	TRANSDUCER, PRESSURE, 0-6000 PSI, 0-5 VDC OUTPUT	1
12	J-6471	MANIFOLD, 695A CONTROL BLOCK	1
13	N-2001-05-S-E	ELBOW, STRAIGHT THREAD	2
14	N-2002-10-S	ELBOW, SWIVEL NUT	1
15	N-2015-28-S-E	TEE, RUN STR THD	1
16	N-2463-03-S-E	FITTING, REDUCER/EXPANDER	1
17	N-2973-S-E	ELBOW, STRAIGHT THREAD	3
18	N-2974-S-E	ELBOW, 45° STR THD	1
19	G-1100-107010	BOLT, 3/16-16 X 1.0 HEX HD GR 5	4
20	G-1250-1070N	FLATWASHER, 3/8 NARROW	4

10.10.2 System Pressure Relief Valve

The System Pressure Relief Valve does not require regular general maintenance. It is possible however, for a contaminant to hold the relief valve in a partially open condition. If service is required, the new or repaired relief valve must be reset to 5,250 psi for the main system relief and 2300 psi for the parasitic system.

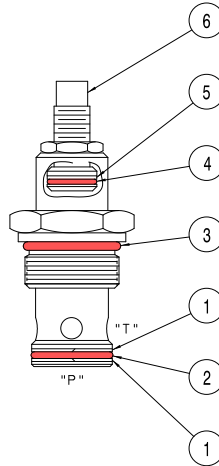

Parts List

Fluid Type: Aviation Phosphate Ester, Type IV, V

Item	Part Number	Description	Qty
1	HC-2037	Ring, Backup	2
2	HC-2006-119	O-ring, Series 2 (EPR)	1
3	HC-2013-916	O-ring, Series 3 (EPR)	1
4	HC-2006-015	O-ring, Series 2 (EPR)	1
5	HC-2020-015	Ring, Backup	1
◆ 6	HC-1772	Valve, Pressure Relief (<i>Phosphate Ester</i>) Not Set	1

◆ Item 6 consists of Items 1 – 5

10.11 FLOW CONTROL MANIFOLD ASSEMBLY

The Control Manifold components do not require regular general maintenance.

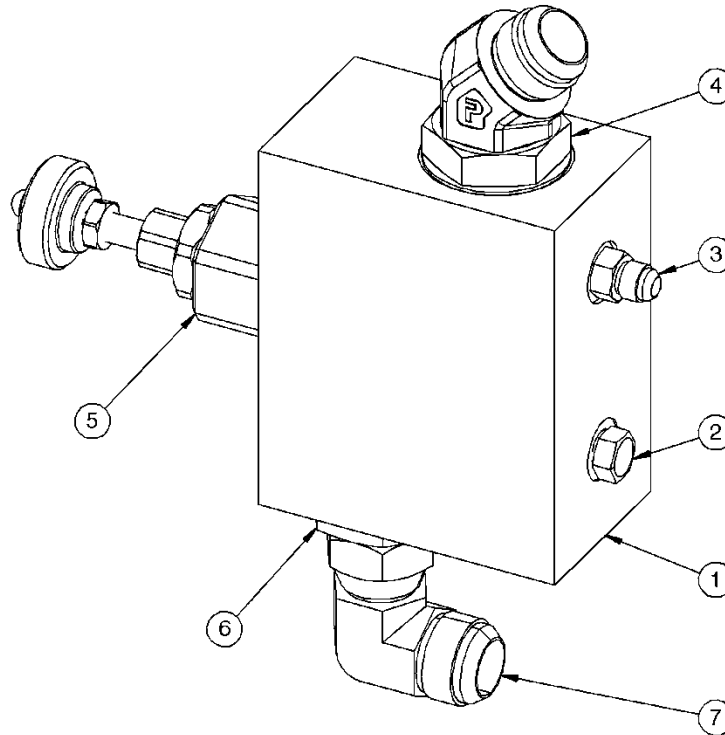

Parts List

Fluid Type: Aviation Phosphate Ester, Type IV, V

Item	Part Number	Description	Qty
1	J-5799	MANIFOLD	1
2	N-2053-05-S-E	PLUG, HEX HD W/ O-RING	1
3	N-2007-08-S-E	CONNECTOR, STR THD	1
4	N-2974-S-E	ELBOW, 45° STR THD	1
5	HC-2214	VALVE NEEDLE (PE)	1
6	N-2007-27-S	CONNECTOR, STR THD	1
7	N-2002-10-S	ELBOW, SWIVEL NUT	1

10.11.1 Flow Control Valve

The Bypass Valve does not require regular general maintenance.

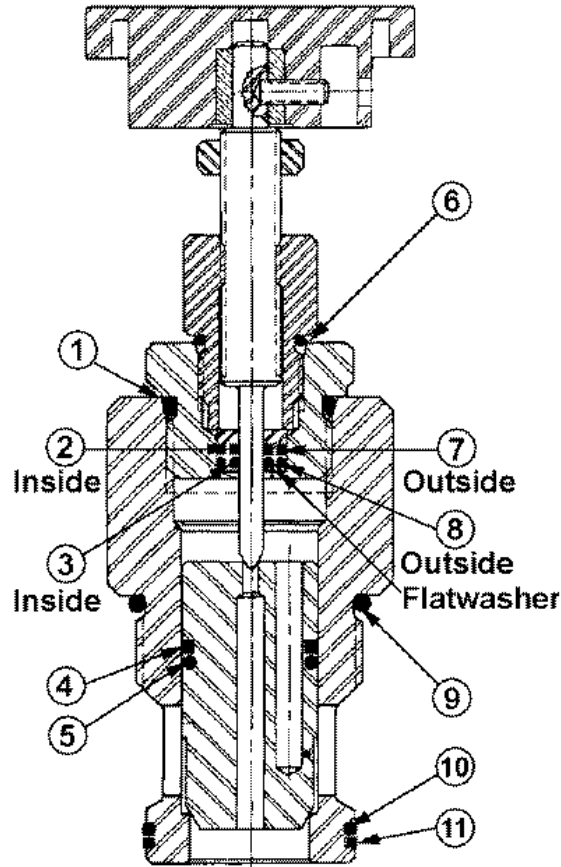

Parts List

Fluid Type: Aviation Phosphate Ester, Type IV, V

Item	Part Number	Description	Qty
1	HC-2013-914	O-ring, Series 3	1
2	HC-2020-008	Ring, Backup (Teflon)	1
3	HC-2006-008	O-ring, Series 3	1
4	HC-2020-019	Ring, Backup (Teflon)	1
5	HC-2006-019	O-ring, Series 2	1
6	HC-2013-908	O-ring, Series 3	1
7	HC-2020-012	Ring, Backup (Teflon)	1
8	HC-2006-012	O-ring, Series 2	1
9	HC-2013-920	O-ring, Series 3	1
10	HC-2006-028	O-ring, Series 2	1
11	HC-2020-028	Ring, Backup (Teflon)	1
◆ 12	HC-2214	Valve, Needle (<i>Phosphate Ester</i>)	1

◆ **Item 12 consists of Items 1 – 11**

10.12 RESERVOIR ASSEMBLY

Replace the desiccant air filter whenever the material inside the element is pink or reddish in color (See Element label for details). The Reservoir Assembly does not require regular general maintenance. If periodic inspections for silt are desired, be certain to thoroughly clean the dome cover and surrounding area before removing the dome

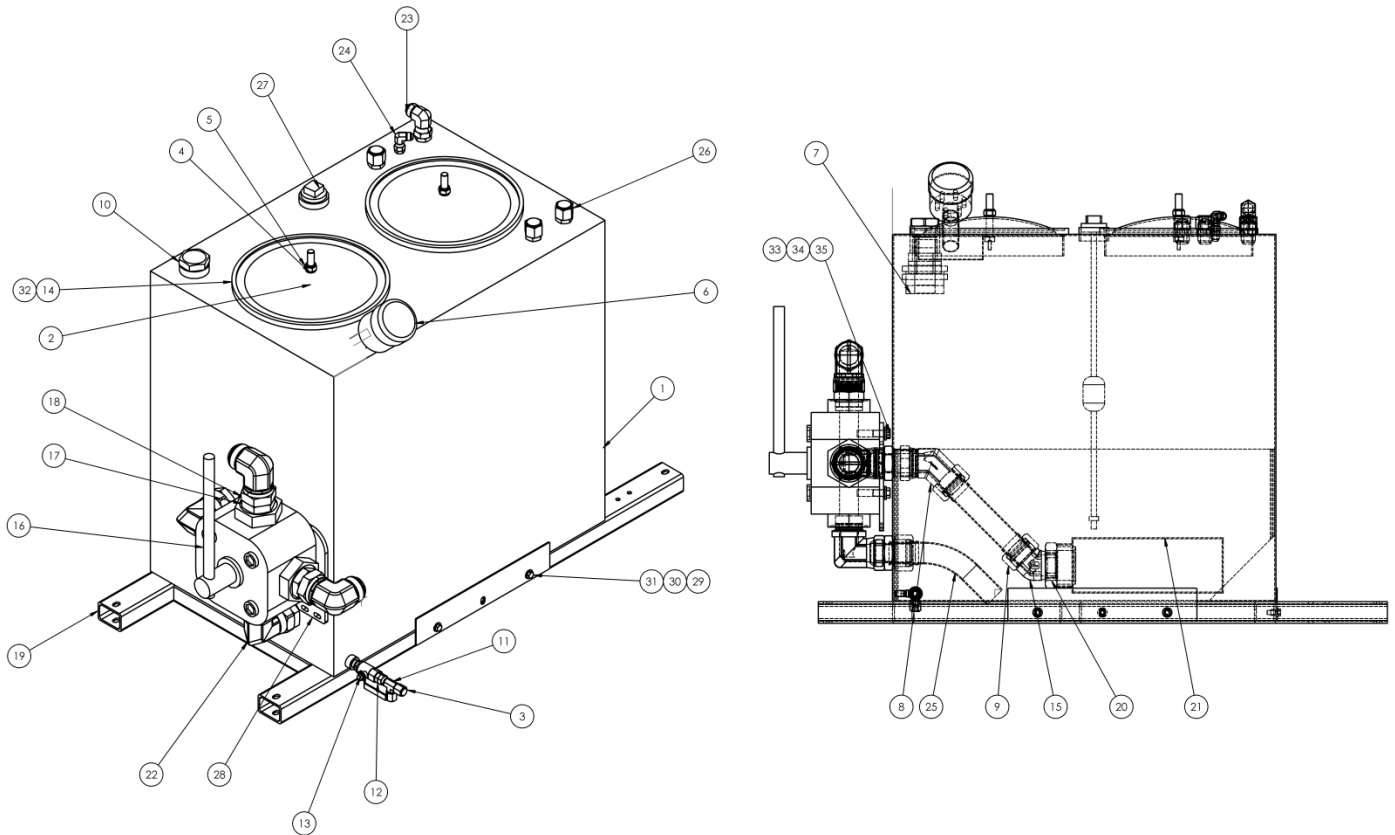

cover.

Parts List

Fluid Type: Aviation Phosphate Ester, Type IV, V

Item	Part Number	Description	Qty
1	Z-9337	WELDMENT, RESERVOIR	1
2	Z-5337	WELDMENT, CLAMP	2
3	N-2008-06-S	CAP, 1/2	2
4	H-1735-02	WASHER, NYLON	2
5	G-1202-1100	STOPNUT, 5/8-11 ELASTIC	2
6	HC-1763	FILTER, DESICCANT	1
7	HC-1542	STRAINER, NIPPLE STYLE	1
8	N-2081-11-S	ELBOW, 45 DEG SWIVEL NUT	1
9	Z-5801	ASSY, HYDRAULIC TUBE	1
10	N-2206-09-S	PLUG, HEX HEAD	1
11	N-2016-06-S	TEE, RUN SWIVEL NUT	1
12	N-2007-11-S-E	CONNECTOR, STR THD	1
13	HC-1761	VALVE, BALL, #8 LOCKABLE	1
14	H-4050	COVER, ACCESS (MB)	2
15	N-2021-29-S	ELBOW, MALE 45 DEG	1
16	HC-2198	VALVE, SELECTOR	1
17	N-2007-33-S-E	CONNECTOR, STR THD	2

10.12 RESERVOIR ASSEMBLY (continued)

Parts List
Fluid Type: Aviation Phosphate Ester, Type IV, V

Item	Part Number	Description	Qty
18	N-2002-13-S	ELBOW, SWIVEL NUT	2
19	Z-9355-01	WELDMENT, RESERVOIR FRAME (P)	1
20	N-2210-31-S	REDUCER, PIPE THREAD	1
21	HC-1397-07	DIFFUSER	1
22	N-2049-32-S-E	ELBOW, 90 DEG SWIVEL	2
23	N-2002-10-S	ELBOW, SWIVEL NUT	1
24	N-2002-06-S	ELBOW, SWIVEL NUT	1
25	Z-5802	ASSEMBLY, HYDRAULIC TUBE	1
26	N-2008-10-S	CAP, 1	3
27	EC-3021	SENSOR, ANALOG FLUID LEVEL	1
28	S-3121-01	PLATE, RESERVOIR SUPPORT (P)	1
29	G-1440-1070-S	NUTSERT, 3/8-16 OPEN END	9
30	G-1503-1070N	FLATWASHER. 3/8 SST NARROW	8
31	G-1112-107010	BOLT, 38-16 X 1.0" SST HEX HD	8
32	H-4099	GASKET, 14" EPDM	2
33	G-1250-1210N	FLATWASHER, 3/4 NARROW	4
34	G-1251-1210R	LOCKWASHER, 9/16 REGULAR	4
35	G-1100-113012	BOLT. 9/16-12 X 1-1/4" HEX HD GR 5	4

10.13 RETURN SYSTEM PRESSURE RELIEF VALVE

The Return System Pressure Relief Valve can be purchased as a preset assembly. If the relief valve is serviced by the end user, the valve must be set to crack at 150+/-7 psig **before** being re-installed on the HPU.

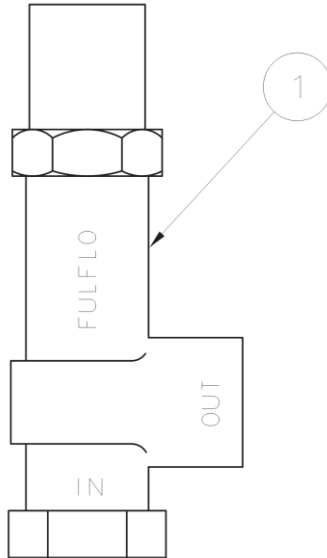

Parts List

Fluid Type: Aviation Phosphate Ester, Type IV, V

Item	Part Number	Description	Qty
1	HC-2202	Valve, Pressure Relief (<i>Pre-set</i>)	1
<i>Not Shown</i>	◆ HC-2006-220	O-ring, Series 2	

◆ *Included with Item 1*

This page left blank intentionally.

10.14 ELECTRICAL COMPONENTS

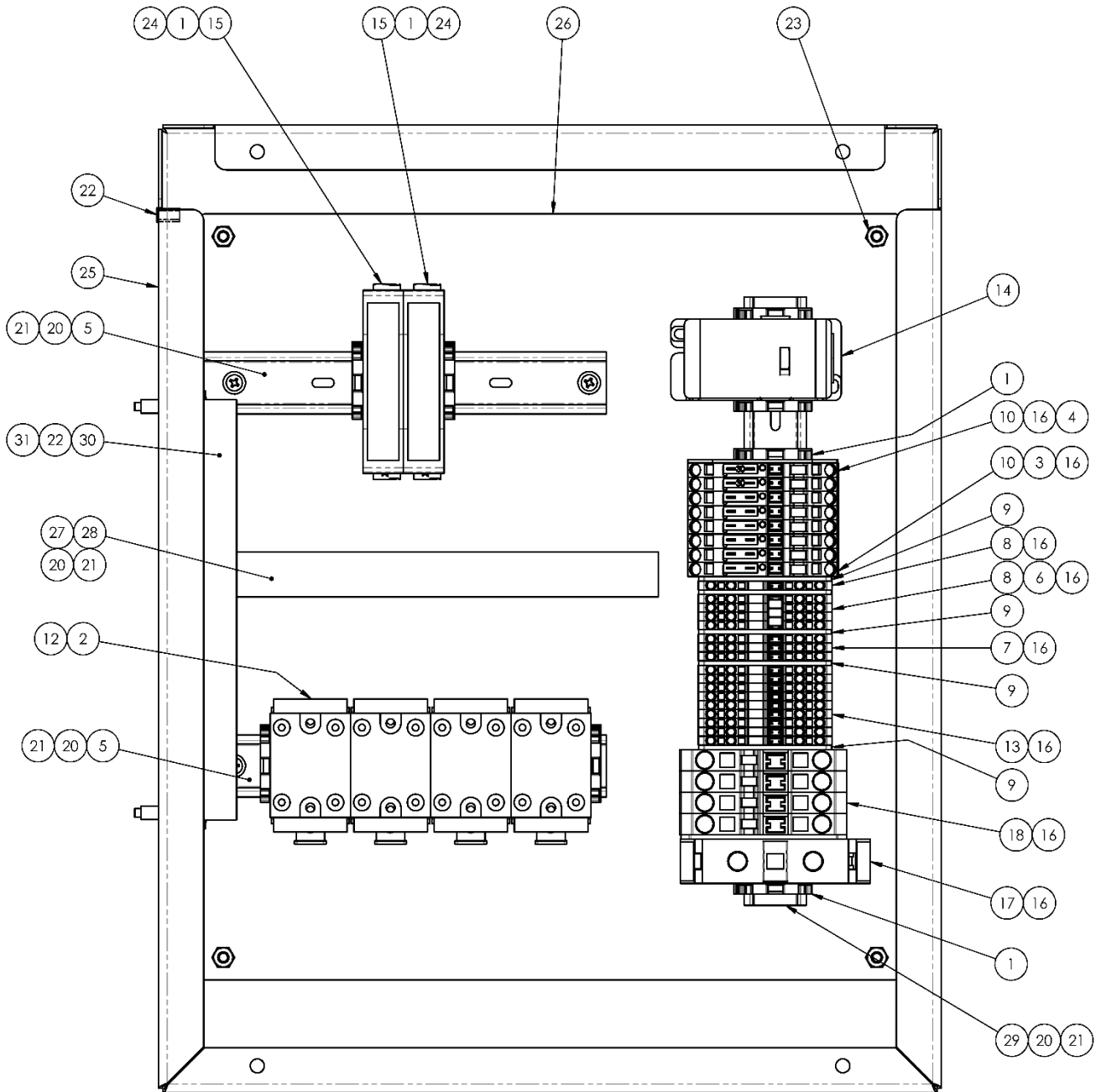

10.14 ELECTRICAL COMPONENTS (continued)

Parts List
Fluid Type: Aviation Phosphate Ester, Type IV, V

Item	Part Number	Description	Qty
1	13070	ANCHOR, DIN RAIL END	8
2	13094	HEAT SINK, RELAY	4
3	ATO-25	25A ATO FUSE	6
4	ATO-30	30A ATO FUSE	2
5	EC-1895-009.00	RAIL, DIN	2
6	EC-2072	JUMPER, 2 CONDUCTOR	3
7	EC-2083	TERMINAL BLOCK, 4 COND LT GRAY	3
8	EC-2084	TERMINAL BLOCK, 4 COND (RED)	5
9	EC-2085	PLATE, END 4C TERMINAL BLOCK	5
10	EC-2422	TERMINAL BLOCK, FUSE HOLDER	8
11	EC-2423	PLATE, END FUSE HOLDER	8
12	EC-2566	RELAY, SOLID STATE (100 AMP)	4
13	EC-2923	BLOCK, TERMINAL GROUNDING	9
14	EC-3430	POWER DISTRIBUTION BLOCK	1
15	EC-3431	ANALOG SIGNAL CONVERTER	2
16	EC-3432	WAGO 2X 1-50 TERMINAL MARKER	1
17	EC-3433	4-4/0 GROUNDING DIN TERMINAL	1
18	EC-3434	24-6 GROUNDING DIN TERMINAL	4
19	EC-3435	24-6 DIN TERMINAL END COVER	1
20	G-1159-103503	SCREW, #10-32 X 3/8" LG. RD HEAD CROSS RECESS MACHINE	10
21	G-1250-1030N	FLATWASHER, #10	20
22	G-1439-1035-S	NUTSERT, #10-32 OPEN END	5
23	G-1501-1050	STOPNUT, 1/4-20 ELASTIC SS	4
25	S-3152-00	BOX, ELECTRICAL PANEL (P)	1
26	S-3175	PANEL, ELECTRICAL (P)	1
27	EC-1710-06*10.0	DUCT, WIRING	1
28	EC-1711-03*10.0	COVER, DUCT WIRING	1
29	EC-1895-013.50	RAIL, DIN	1
30	EC-3542	CONVERTER, 72VDC/12VDC	1
31	G-1157-103506	SCREW, #10-32 X 3/4 LG PAN HD	4

- 10.15 CASE DRAIN
- 10.15.1 Case Cooler

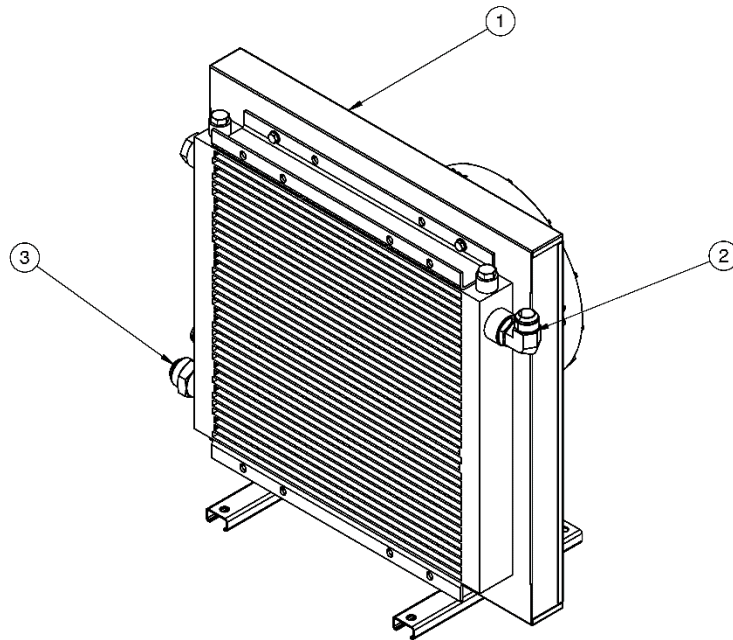

Parts List

Fluid Type: Aviation Phosphate Ester, Type IV, V

Item	Part Number	Description	Qty
1	HC-2775	COOLER, OIL	1
2	N-2001-24-S-E	ELBOW, STRAIGHT THREAD	1
3	N-2007-28-S-E	CONNECTOR, STRAIGHT THREAD	1

10.15.2 Para Cooler Upper

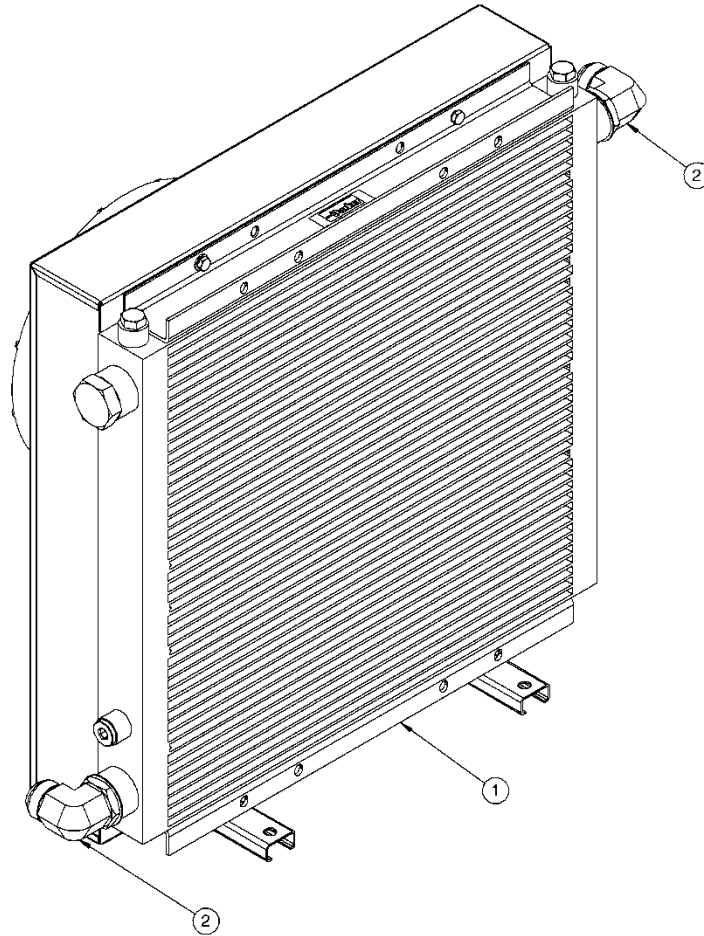

Parts List

Fluid Type: Aviation Phosphate Ester, Type IV, V

Item	Part Number	Description	Qty
1	HC-2750	COOLER, OIL	1
2	N-2001-28-S-E	ELBOW, STRAIGHT THREAD	2

10.15.3 Para Cooler Lower

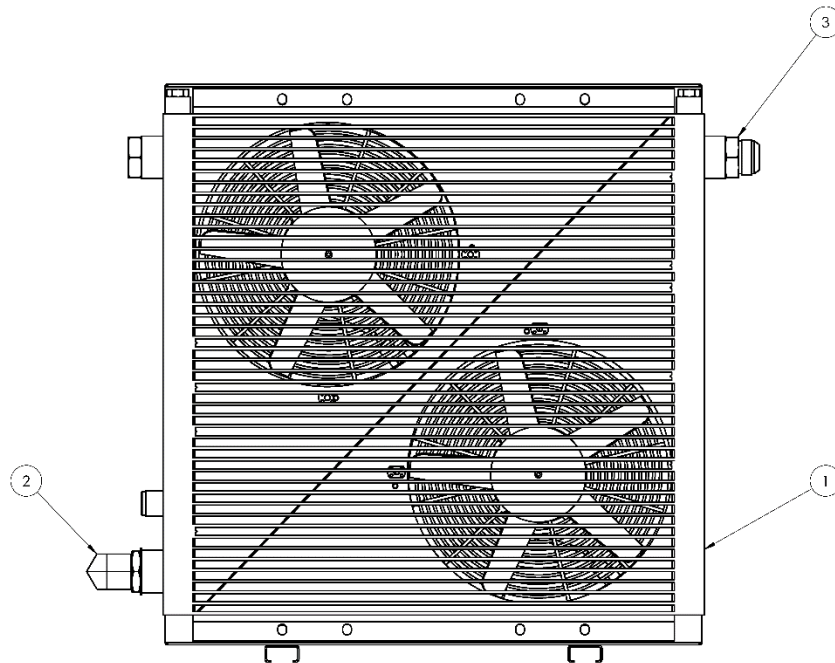

Parts List

Fluid Type: Aviation Phosphate Ester, Type IV, V

Item	Part Number	Description	Qty
1	HC-2750	COOLER, OIL	1
2	N-2001-28-S-E	ELBOW, STRAIGHT THREAD	2
3	N-2007-28-S-E	CONNECTOR, STRAIGHT THREAD	1

This page left blank intentionally.

10.16 EXTERNAL COMPONENTS

Keep HPU clean. Do not allow labels to become damaged; thusly illegible.

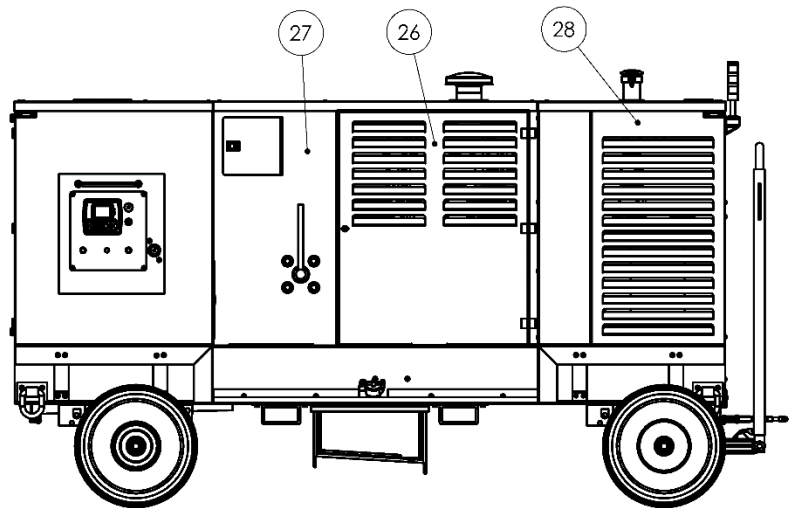
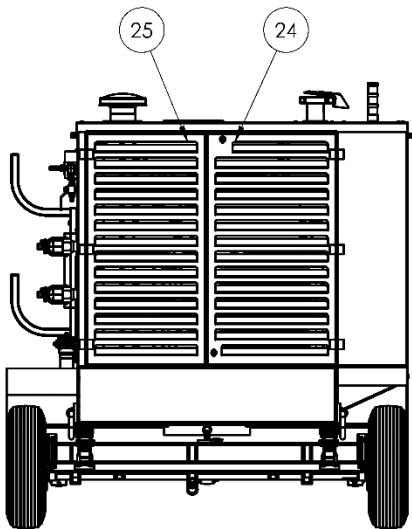
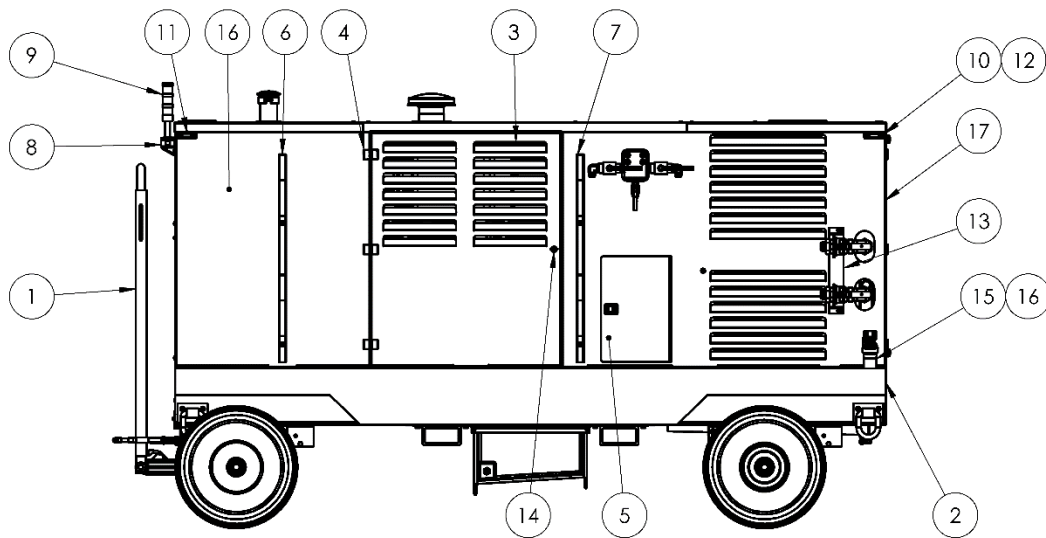
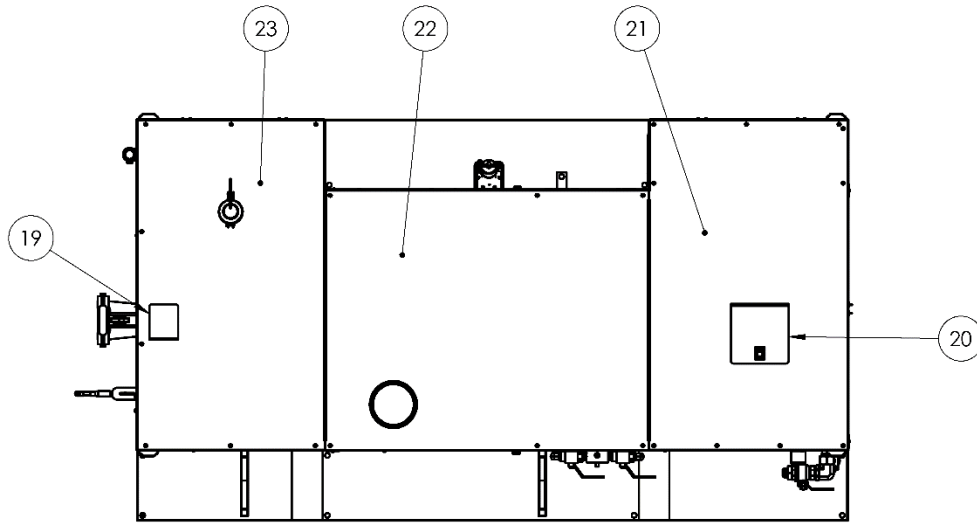

10.16 EXTERNAL COMPONENTS (continued)

Parts List

Item	Part Number	Description	Qty
1	Z-9441	ASSY, INTERNAL ELECTRICAL	1
2	S-3099	TRAY, HOSE	1
3	Z-9437-01	WELDMENT, LEFT SIDE DOOR (P)	1
4	H-2827	HINGE, DOOR	12
5	Z-9392	ASSEMBLY, ACCESS DOOR	1
6	Z-9473-01	WELDMENT, HOSE HANGER (P)	2
7	H-2338	CAP, END	6
8	EC-1794	BOX, VERTICLE MOUNT JUNCT.	1
9	EC-3026	LIGHT, TOWER, GRM, AMBT, RED 24V	1
10	EC-2709	BASE, BLACK FOR 169 LED LIGHT	4
11	EC-3521	ASSY, LIGHT SIDE MARKER(AMBER)	2
12	EC-3520	ASSY, LIGHT SIDE MARKER (RED)	2
13	S-3168-01	BRACKET, RETURN VALVES (P)	1
14	H-4100	LATCH, DOOR	4
15	HC-1954	ASSEMBLY, FILTER 15CN 2 MICRON (PE)	1
16	J-6203	BRACKET, FILTER MOUNTING	1
17	Z-12582	WELDMENT, BACK LEFT PANEL	1
18	S-3133	SHEETMETAL, FRONT L/S	1
19	Z-6168-01	LID, RADIATOR ACCESS (P)	1
20	Z-9398	ASSEMBLY, ACCESS DOOR	2
21	Z-9399	WELDMENT, TOP REAR PANEL	1
22	S-3137	TOP PANEL, CENTER	1
23	S-3136	TOP PANEL, FRONT	1
24	Z-9472-01	WELDMENT, REAR DOOR (P)	1
25	S-3128-00	SHEETMETAL, LEFT REAR DOOR	1
26	Z-9436-01	WELDMENT, RIGHT SIDE DOOR (P)	1
27	Z-9487	WELDMENT, SELECTOR VALVE	1
28	S-3130	SHEETMETAL, SCR	1

10.16.1 Hydraulic Coupling

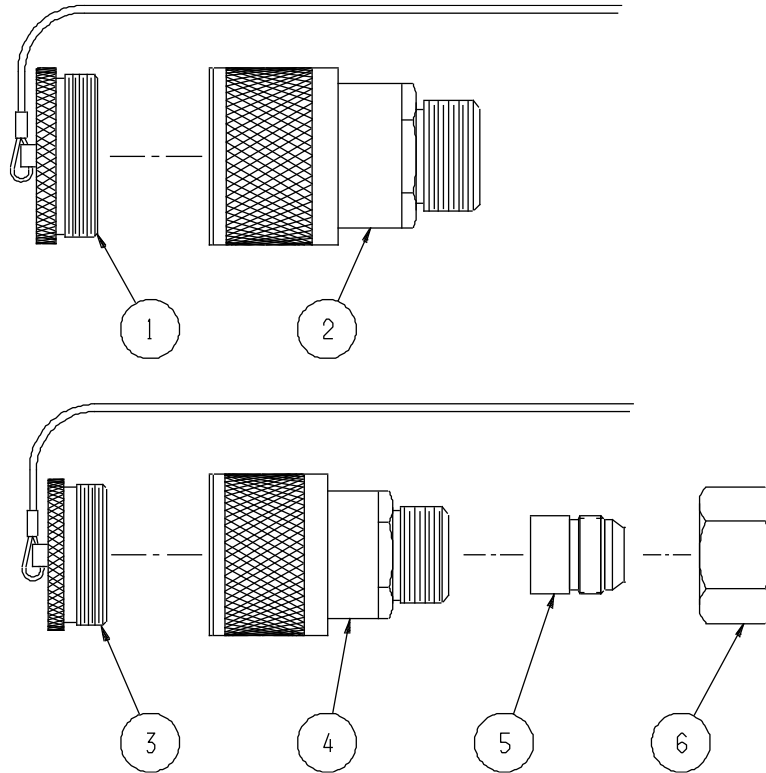

Parts List

Fluid Type: Aviation Phosphate Ester, Type IV, V

Item	Part Number	Description	Qty
1	N-2474-05	PLUG, DUST	1
2	N-2480	COUPLING, QUICK DISCONNECT	1
3	N-2474-04	PLUG, DUST	1
4	N-2479	COUPLING, QUICK DISCONNECT	1
5	N-2020-17-S	REDUCER, TUBE	1
6	N-2000-11-S	NUT	1

10.17 FLOWMETER ASSEMBLY

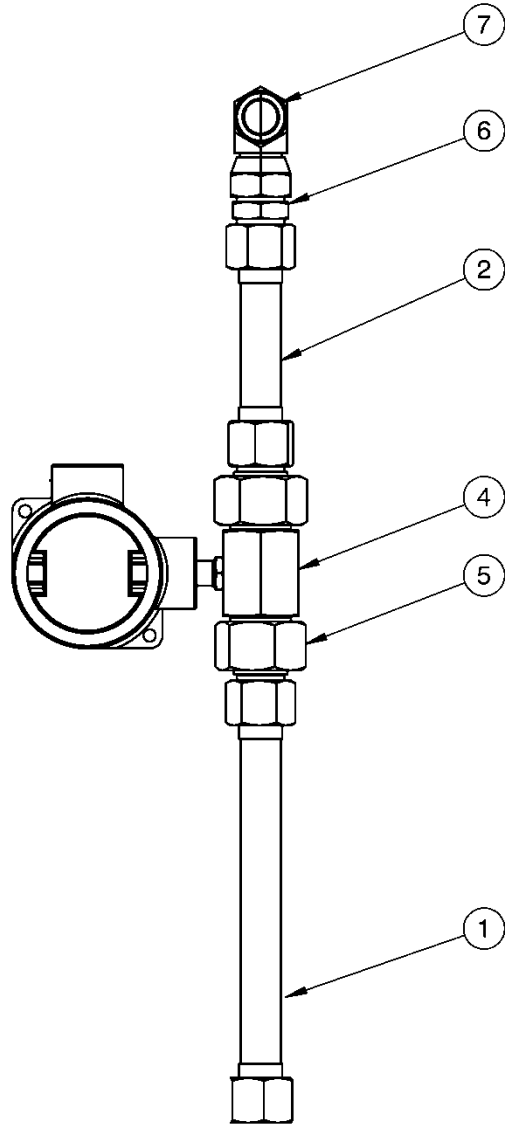

Parts List

Fluid Type: Aviation Phosphate Ester, Type IV, V

Item	Part Number	Description	Qty
1	Z-9306	ASSEMBLY, INPUT TUBE (10 DIA TUBE)	1
2	Z-9305	ASSEMBLY, OUTPUT TUBE (5 DIA TUBE)	1
4	Z-11492 =	FLOWMETER ASSEMBLY	1
5	N-2020-17-S	REDUCER, TUBE (20-16)	2
6	N-2011-10-S	UNION, #16 JIC	1
7	N-2002-10-S-E	ELBOW, SWIVEL NUT	1

10.18 ELECTRIC RESERVOIR LEVEL

Annual calibration of instrumentation is recommended. See Section **12.0 – Calibration of Instrumentation** for details of calibration.

NOTE: Wire per Electrical Schematic INS-2143. Reference Wiring Diagram INS-2169. Reference 9.7.1 Electrical Panel for Panel Light.

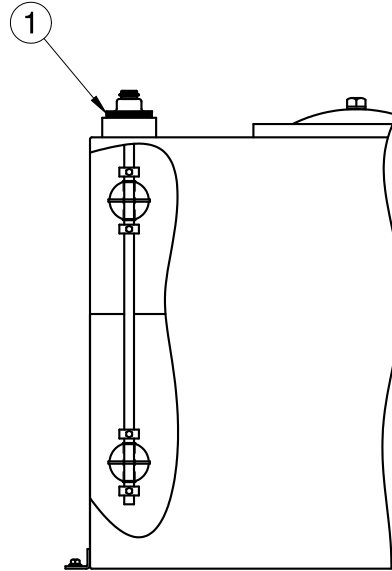

Parts List

Item	Part Number	Description	Qty
1	EC-3021	SENSOR, FLUID LEVEL	1

10.19 FILL PUMP

Refer to Section **9.6 Hydraulic Hoses** concerning hose inspection for general maintenance on hose assemblies.
Refer to Section **9.5.3 – Hand Pump Filter** .

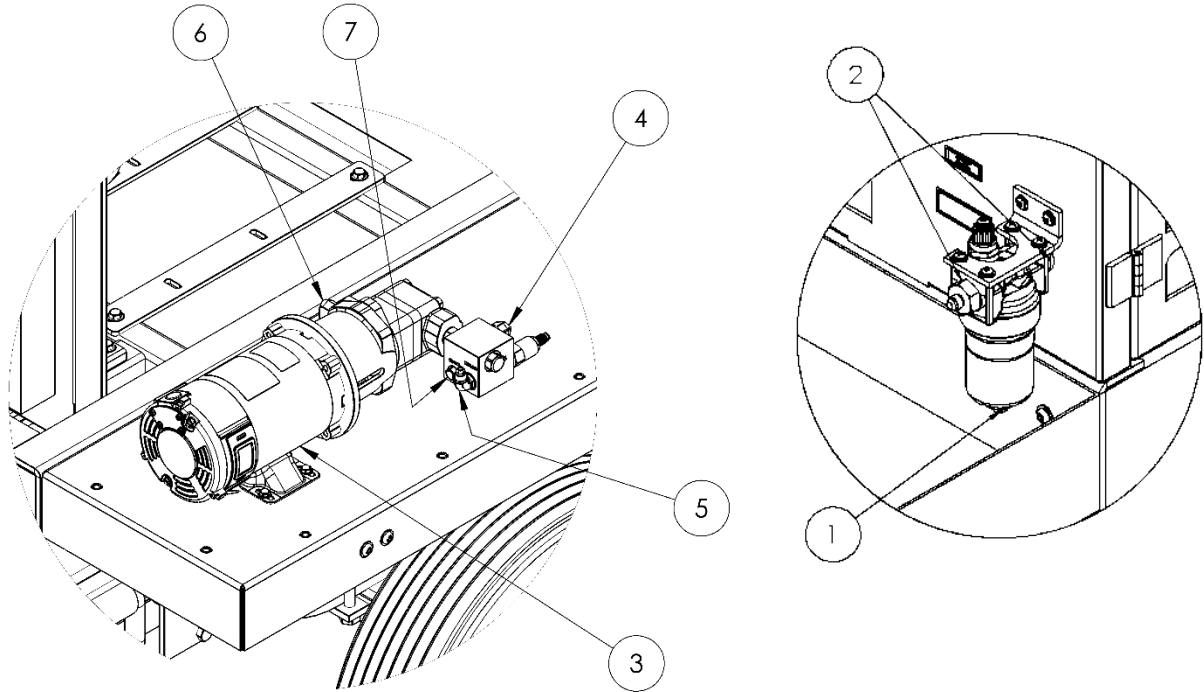

Parts List

Fluid Type: Aviation Phosphate Ester, Type IV, V

Item	Part Number	Description	Qty
1	HC-1954	FILTER, 15CN X 2 MICRON PE	1
2	N-2007-46	CONNECTOR, STRAIGHT THREAD	2
3	HC-2779	PUMP, 24VDC ELECTRIC FILL	1
4	N-2001-06-S-E	ELBOW, STRAIGHT THREAD	1
5	N-2001-08-S-E	ELBOW, STRAIGHT THREAD	1
6	N-2001-11-S-E	ELBOW, STRAIGHT THREAD	1
7	N-2053-03-S-E	PLUG, HEX HD W/ O RING	1

10.20 TOWING TRAILER

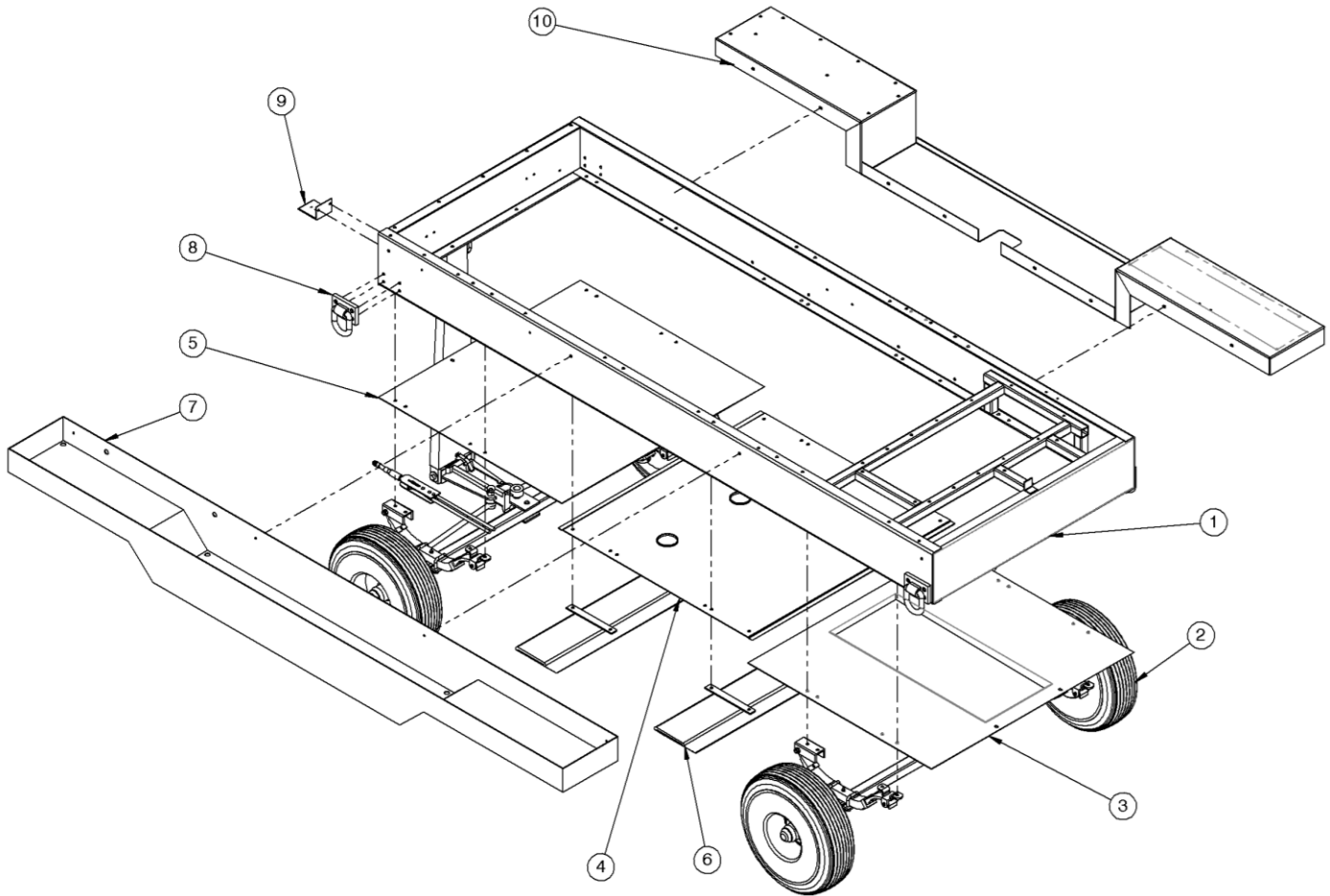

Parts List

Item	Part Number	Description	Qty
1	Z-9309-01	WELDMENT, FRAME	1
2	H-4065	TRAILER, RUNNING GEAR	1
3	S-3117	DRIP PAN, FRONT	1
4	S-3116	DRIP PAN, MIDDLE	1
5	S-3115	DRIP PAN, REAR	1
6	Z-9361-01	WELDMENT, FORKLIFT TUBE	2
7	S-3099	TRAY, HOSE	1
8	H-3564-00	D-RING W/BOLT PLATE	4
9	A-1287-01	ANGLE, BRACKET (P)	1
10	S-3173-01	TRAY, CONTROLS SIDE	1

10.21 REPLACEMENT LABELS PARTS LISTS

10.21.1 Base Unit

Part Number	Description	Qty
V-1340-04	"TRONAIR"	1
V-2427	"LUBE FILTER"	1
V-2428	"FUEL FILTER"	1
V-2429	"AIR FILTER"	1
V-2430	"OIL FILTER"	1
V-2433	"BATTERY SWITCH"	1
V-1893	"SAMPLE VALVE"	1
V-1894	"PRESSURE"	1
V-1895	"RETURN"	1
V-1986	"READ MANUAL"	1
V-2390	"EPA EMISSIONS"	1
V-2074	"MAX TOWING"	1
V-1900	"WARNING KEEP 5 FT CLEAR . . ."	2
V-2434	"HYDRAULIC PANEL"	1
V-2436	"OPERATING INSTRUCTIONS . . ."	1
V-2432	"FILL RATE"	1
V-2111	"DIESEL OR JET A"	1
V-2453	"Tire Pressure"	4
V-2023	"Forklift Point"	4

10.21.2 Fluid Labels

Fluid Type: Aviation Phosphate Ester, Type IV

Part Number	Description	Qty
V-1977	"PHOSPHATE ESTER FLUIDS ONLY"	2

10.21.3 Filter Element Kit Labels

Fluid Type: Aviation Phosphate Ester, Type IV

Part Number	Description	Qty
V-1960	"REPLACEMENT FILTER ELEMENT K-3614"	1
V-1962	"REPLACEMENT FILTER ELEMENT K-3616"	1
V-1916	"REPLACEMENT DESICCANT FILTER ELEMENT HC-1763"	1

11.0 PROVISION OF SPARES

11.1 SOURCE OF SPARE PARTS

Spare parts may be obtained from the manufacturer:

TRONAIR, Inc.	Telephone: (419) 866-6301 or 800-426-6301
1 Air Cargo Pkwy East	Fax: (419) 867-0634
Swanton, Ohio 43558 USA	E-mail: sales@tronair.com
	Website: www.tronair.com



For Spare Parts, Operations & Service Manuals or Service Needs:
Scan the QR code or visit tronair.com/pages/tronair-information-center

11.2 RECOMMENDED SPARE PARTS LISTS

It is recommended that the following spare parts be kept on hand and available for immediate use during maintenance.

11.2.1 Spare Parts

Fluid Type: Aviation Phosphate Ester, Type IV

Part Number	Description	Qty
HC-1763	Desiccant Filter Element	1
K-3588	Kit, Pressure Filter Element	1
K-3587	Kit, Return Filter Element	1
L517107-004	Kit, Shaft Seal and Retainer for Main Pump	1
K-3752	Kit, Fill Pump Filter Element	1
TF-1117-38-300	25 ft Pressure Hose	4
TF-1041-04*300	25 ft Return Hose	4
TF-1041-02*300	25 ft Fill Pump Hose	2
H-4208	Fuel Filter	1
H-4207	Lubricity Filter	1
H-4209	Oil Filter	1
H-4159	Air Filter	1

12.0 CALIBRATION OF INSTRUMENTATION

All gauges on the Hydraulic Power Unit can be either returned to Tronair for calibration or certified by the end user if proper calibration equipment is available. Gauges returned to Tronair for calibration will be tested with standards traceable to N.I.S.T. (National Institute of Standards and Technology). Tronair recommends calibration of instrumentation at yearly intervals, but actual calibration dates may be based upon frequency of use and the end users quality system. For information on returning gauges for calibration, Reference **12.1 – Source of Calibration**.

12.1 SOURCE OF CALIBRATION

TRONAIR, Inc.	Telephone: (419) 866-6301 or 800-426-6301
1 Air Cargo Pkwy East	Fax: (419) 867-0634
Swanton, Ohio 43558 USA	E-mail: sales@tronair.com
	Website: www.tronair.com

13.0 IN SERVICE SUPPORT

Contact Tronair, Inc. for technical services and information.

14.0 GUARANTEES/LIMITATION OF LIABILITY

Tronair products are warranted to be free of manufacturing or material defects for a period of one year after shipment to the original customer. This is solely limited to the repair or replacement of defective components. This warranty does not cover the following items:

- a) Parts required for normal maintenance
- b) Parts covered by a component manufacturers warranty
- c) Replacement parts have a 90-day warranty from date of shipment

If you have a problem that may require service, contact Tronair immediately. Do not attempt to repair or disassemble a product without first contacting Tronair, any action may affect warranty coverage. When you contact Tronair be prepared to provide the following information:

- a) Product Model Number
- b) Product Serial Number
- c) Description of the problem

If warranty coverage is approved, either replacement parts will be sent or the product will have to be returned to Tronair for repairs. If the product is to be returned, a Return Material Authorization (RMA) number will be issued for reference purposes on any shipping documents. Failure to obtain a RMA in advance of returning an item will result in a service fee. A decision on the extent of warranty coverage on returned products is reserved pending inspection at Tronair. Any shipments to Tronair must be shipped freight prepaid. Freight costs on shipments to customers will be paid by Tronair on any warranty claims only. Any unauthorized modification of the Tronair products or use of the Tronair products in violation of cautions and warnings in any manual (including updates) or safety bulletins published or delivered by Tronair will immediately void any warranty, express or implied.

The obligations of Tronair expressly stated herein are in lieu of all other warranties or conditions expressed or implied. **Any unauthorized modification of the Tronair products or use of the Tronair products in violations of cautions and warnings in any manual (including updates) or safety bulletins published or delivered by Tronair will immediately void any warranty, express or implied and Tronair disclaims any and all liability for injury (WITHOUT LIMITATION and including DEATH), loss or damage arising from or relating to such misuse.**

15.0 APPENDICES

APPENDIX I	Hydraulic Schematic (INS-2371)
APPENDIX II	Electrical Schematic (INS-2383)
APPENDIX III	Safety Data Sheet (SDS) Hydraulic Fluid
APPENDIX IV	Instrument Certification Notice

See manufactures' websites for:

FPT Diesel Engine Manual



APPENDIX I

Hydraulic Schematic (INS-2371)

THIS DRAWING IS THE PROPERTY OF TRONAIR, INC. IT IS FURNISHED TO YOU FOR CONFIDENTIAL INFORMATION PURPOSES ONLY AND IS NOT TO BE DISCLOSED TO ANYONE ELSE OR REPRODUCED OR USED FOR MANUFACTURING PURPOSES WITHOUT THE EXPRESS WRITTEN PERMISSION OF TRONAIR, INC.

LET	REVISION	ECN	DWN	CHK	DATE
A	ORIGINAL RELEASE	20302	-	-	05-12-17

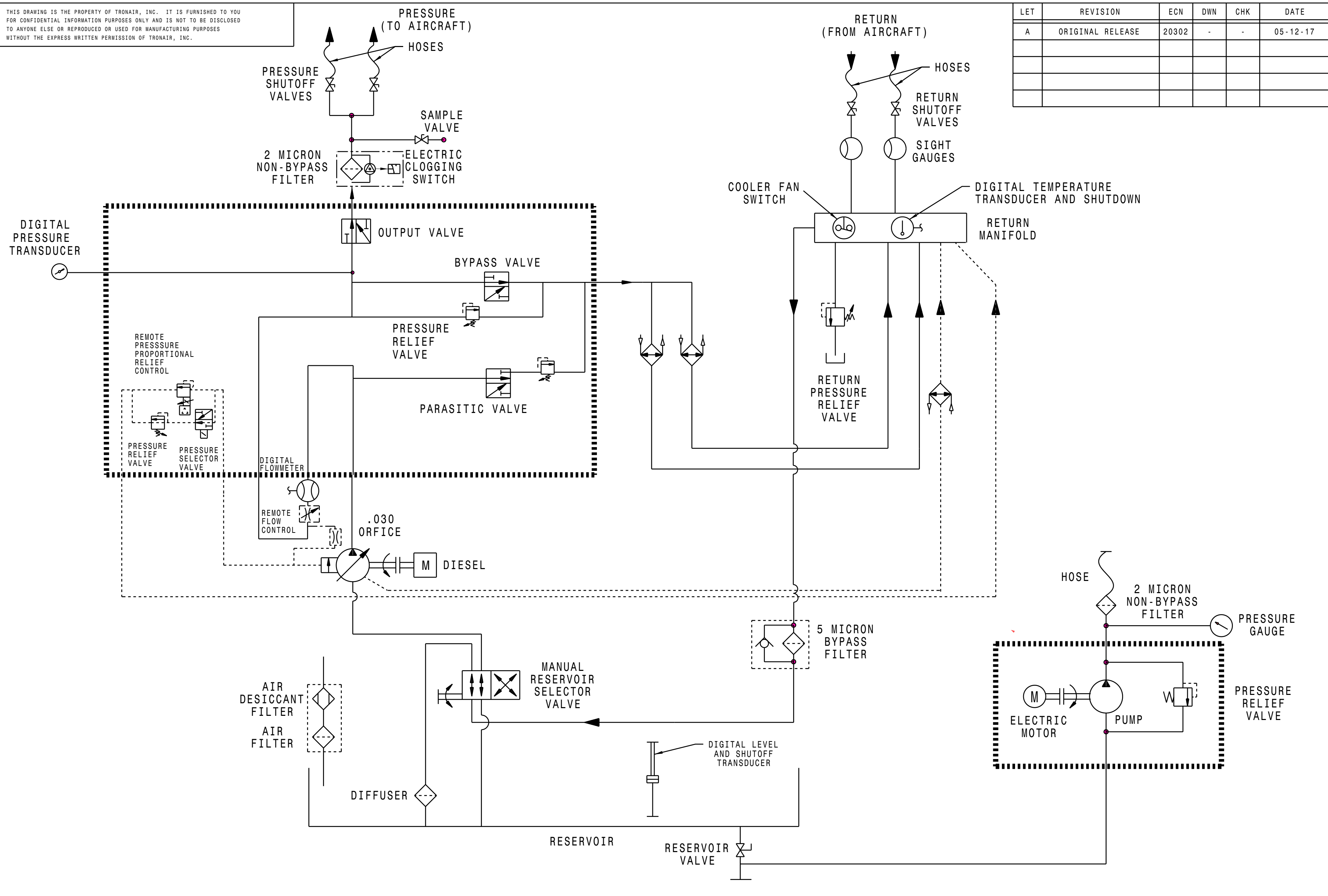

MAKE FROM: N / A	TYPE: N / A
MATERIAL: N / A	FINISH: N / A
REFERENCE: N / A	SIZE: C
SCALE: FULL	DO NOT SCALE DRAWING

BREAK ALL SHARP EDGES AND CORNERS
TOLERANCES UNLESS OTHERWISE SPECIFIED

DECIMAL .X ± .100
.XX ± .030
.XXX ± .010

FRACTION X/XX ± 1/16

ANGLES: ± 1/2 DEGREE

< > INDICATES CRITICAL DIMENSIONS
() INDICATES REFERENCE DIMENSIONS

TRONAIR AIRCRAFT GROUND SUPPORT EQUIPMENT

DWN BY **EMB** CKD BY **CDG** 05-12-17

SCHEMATIC, HYDRAULIC

05 **INS-2371** REV **A**



APPENDIX II

Electrical Schematic (INS-2383)

REVISIONS					
REV	DESCRIPTION	EC#	DWN	CHK	DATE
A	ORIGINAL RELEASE	20477	-	-	XX/XX/XXXX
B	REDESIGNED	23608	NCS	PEH	7/19/2022
C	ADDED 2ND SIGNAL CONDITIONER FOR PROP. REL. VALVE	24497	NCS	PEH	10/4/2022
D	ADDED DC-DC CONVERTER, UPDATED PER BUILD	25293	NGL	PEH	07-03-2023
E	ADDED ENGINE BLOCK GROUND	27694	PRB	KJY	1/16/2025
F	REVISED PINOUTS FOR EC-3514 AND H-4047 BASED ON BUILD FEEDBACK	27685	PRB	KJY	2/13/2025

FUSING CHART	
TF1	30A
TF2	30A
TF3	25A
TF4	25A
TF5	25A
TF6	25A
TF7	25A
TF8	25A

- LEGEND:
- [TF] FUSED DIN TERMINAL
 - [GT] GROUNDING DIN TERMINAL
 - [TI] NORMAL DIN TERMINAL
 - TERMINAL JUMPER (+24V)
 - GROUND CONNECTION
 - SPLICE

MURPHY MPC-20 CONTROLLER AND HARNESS CONNECTIONS	
B+	BAT+ (RED) 18 GA
B-	BAT- (GRY) 18 GA
ENGINE CONN	TO ENGINE
B- KEY D	70 (GRY) 18 GA
USB	
STOP-A	STOP-A (GRY) 18 GA
D1	HYD FILTER (WHT) 18 GA
D2	STOP-B 18 GA
D3	NOT USED
D4	BYPASS INPUT INC PRESS (WHT) 18 GA
D5	NOT USED
D6	KEY A 65 (WHT) 18 GA
SV_DO1	LIGHT-GRN (WHT) 18 GA
SV_DO2	FAN EN (WHT) 18 GA
HS_DO1	LIGHT-YEL (WHT) 18 GA
HS_DO2	LIGHT-RED (WHT) 18 GA
LS_DO2	PHL LIGHTS (BLK) 18 GA
R3	PARASITIC PARASITIC (WHT) 18 GA
R4	BYPASS BYPASS (WHT) 18 GA
R5	OUTPUT OUTPUT (WHT) 18 GA
R6	PRESSURE SELECT PRESS SEL (WHT) 18 GA
A01	PROP RELIEF PROP RELIEF (WHT) 18 GA
A1	FUEL LEVEL FUEL LEVEL (WHT) 18 GA
A12	HYD FLOW HYD FLOW (WHT) 18 GA
A13	HYD OIL PRESS HYD PRESS (WHT) 18 GA
A14	HYD RES LEVEL HYD LEVEL (WHT) 18 GA
A15	HYD OIL TEMP HYD TEMP (WHT) 18 GA
A16	NOT USED
A17	NOT USED
A18	PRESSURE RELIEF PRESS RELIEF (WHT) 18 GA

EC-3431 SIGNAL CONDITIONER (Reservoir level)	
1	INPUT 1 25-02 (BLK) 18 GA
2	INPUT 2
3	INPUT 3
4	INPUT 4 25-03 (BLK) 18 GA
5	INPUT 5
6	INPUT 6 25-01 (BLK) 18 GA
7	ANALOG OUTPUT 7 HYD LEVEL (WHT) 18 GA
8	ANALOG OUTPUT 8 34-08 (BLK) 18 GA
9	ANALOG OUTPUT 9
10	ANALOG OUTPUT 10
11	POWER + 34-11 (RED) 18 GA
12	POWER - 34-12 (BLK) 18 GA
13	RELAY 2 COM
14	RELAY 2 NO
15	RELAY 2 NC
16	RELAY 1 COM
17	RELAY 1 NO
18	RELAY 1 NC

EC-3431 SIGNAL CONDITIONER (proportional valve)	
1	INPUT 1 PROP RELIEF (WHT) 18 GA
2	INPUT 2
3	INPUT 3 35-04 (BLK) 18 GA
4	INPUT 4
5	INPUT 5
6	INPUT 6
7	ANALOG OUTPUT 7 21-11 (WHT) 18 GA
8	ANALOG OUTPUT 8 35-08 (BLK) 18 GA
9	ANALOG OUTPUT 9
10	ANALOG OUTPUT 10 35-10 (BLK) 18 GA
11	POWER + 35-11 (RED) 18 GA
12	POWER - 35-12 (BLK) 18 GA
13	RELAY 2 COM
14	RELAY 2 NO
15	RELAY 2 NC
16	RELAY 1 COM
17	RELAY 1 NO
18	RELAY 1 NC

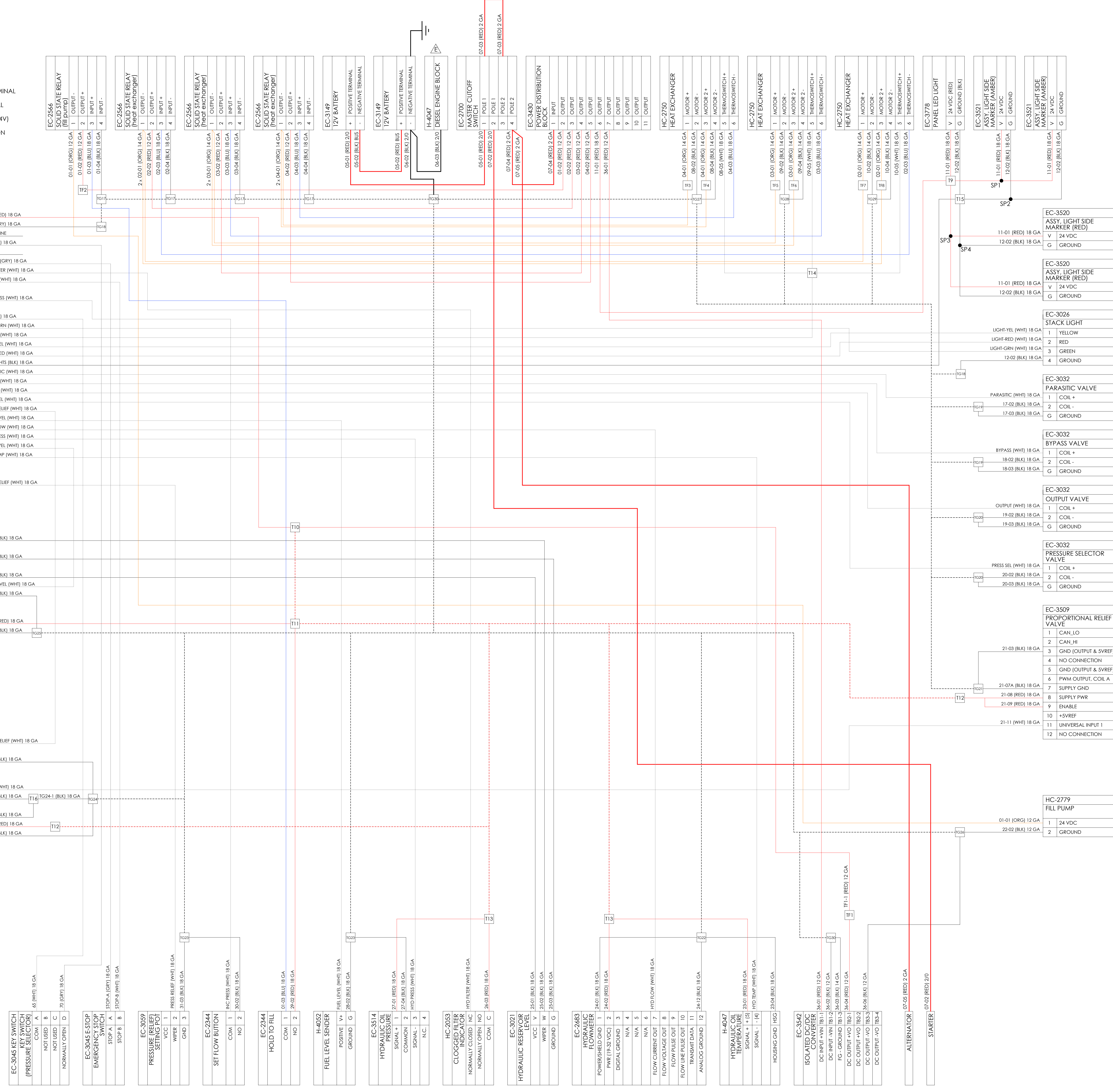

NOTES:
1. REFERENCE INS-2747 TERMINATION SPREADSHEET AND INS-2802 WIRING DIAGRAM.

TYPED FROM: N/A TITLE: N/A TRIP: N/A THIRD ANGLE PROJECTION:	BREAK ALL SHARP EDGES AND CORNERS (HIDDEN) PER ASME Y14.25-2019 DIMENSIONS IN INCHES AND TOLERANCES PER BELOW UNLESS OTHERWISE SPECIFIED: DIMENSION INCH (mm) XX (XX) ± .01 (0.25) XXX (XXX) ± .010 (0.254) XXXX (XXXX) ± .005 (0.127) FRACTION INCH (mm) 1/16 (1.56) ± .001 (0.025) ANGULAR DEGREE (RADIAN): X (XXX) ± .5 (1.0)	TRONAIR <small>AMERICAN AIRPORT EQUIPMENT</small> DATE: 10/30/2017 DRAWN BY: JP CHECKED BY: CDG INS. ELECTRICAL SCHEMATIC INS-2383 SCALE: 1:4 SIZE: E WEIGHT: 0.00 LB SHEET 1 OF 1
---	---	---



APPENDIX III

Safety Data Sheet Hydraulic Fluid

Skydrol® LD4 Fire Resistant Hydraulic Fluid

Version Revision Date: SDS Number: Date of last issue: 06/02/2015
2.2 08/09/2016 150000093409 Date of first issue: 10/24/2013
SDSUS / PRD / 0001

SECTION 1. IDENTIFICATION

Product name : Skydrol® LD4 Fire Resistant Hydraulic Fluid

Product code : P3410201

Manufacturer or supplier's details

Company name of supplier : Eastman Chemical Company

Address : 200 South Wilcox Drive
 Kingsport TN 37660-5280

Telephone : (423) 229-2000

Emergency telephone number : CHEMTREC: +1-800-424-9300, +1-703-527-3887 CCN7321
 For emergency transportation information, in the United States:
 call CHEMTREC at 800-424-9300 or call 423-229-2000.

Recommended use of the chemical and restrictions on use

Recommended use : Hydraulic fluids

Restrictions on use : None known.

SECTION 2. HAZARDS IDENTIFICATION**GHS Classification**

Skin irritation : Category 2

Carcinogenicity : Category 2

GHS label elements

Hazard pictograms :



Signal word : Warning

Hazard statements : H315 Causes skin irritation.
 H351 Suspected of causing cancer.

Precautionary statements : **Prevention:**
 P201 Obtain special instructions before use.
 P202 Do not handle until all safety precautions have been read
 and understood.
 P264 Wash skin thoroughly after handling.
 P280 Wear protective gloves/ protective clothing/ eye protection/
 face protection.

Skydrol® LD4 Fire Resistant Hydraulic Fluid

Version Revision Date: SDS Number: Date of last issue: 06/02/2015
 2.2 08/09/2016 15000093409 Date of first issue: 10/24/2013
 SDSUS / PRD / 0001

Response:

P302 + P352 IF ON SKIN: Wash with plenty of soap and water.
 P308 + P313 IF exposed or concerned: Get medical advice/
 attention.

P332 + P313 If skin irritation occurs: Get medical advice/
 attention.

P362 Take off contaminated clothing and wash before reuse.

Storage:

P405 Store locked up.

Disposal:

P501 Dispose of contents/ container to an approved waste disposal plant.

Other hazards

None known.

SECTION 3. COMPOSITION/INFORMATION ON INGREDIENTS**Components**

Chemical name	CAS-No.	Concentration (% w/w)
Tributyl phosphate	126-73-8	55 - 65
Dibutylphenylphosphate	2528-36-1	20 - 30
Butyl diphenyl phosphate	2752-95-6	5 - 10
7-Oxabicyclo[4.1.0]heptane-3-carboxylic acid, 2-ethylhexyl ester	62256-00-2	< 10
butylated hydroxytoluene	128-37-0	1

SECTION 4. FIRST AID MEASURES

- If inhaled : Move to fresh air.
 If breathing is difficult, give oxygen.
 Consult a physician if necessary.
- In case of skin contact : Wash off immediately with plenty of water for at least 15 minutes.
 Get medical attention if symptoms occur.
 Wash contaminated clothing before reuse.
- In case of eye contact : In case of contact, immediately flush eyes with plenty of water for at least 15 minutes.
 Get medical attention if symptoms occur.
- If swallowed : Call a physician or poison control centre immediately.
 Do not induce vomiting without medical advice.
 Rinse mouth.
 Never give anything by mouth to an unconscious person.
- Most important symptoms and effects, both acute and delayed : Causes skin irritation.
 Suspected of causing cancer.

Skydrol® LD4 Fire Resistant Hydraulic Fluid

Version Revision Date: SDS Number: Date of last issue: 06/02/2015
 2.2 08/09/2016 150000093409 Date of first issue: 10/24/2013
 SDSUS / PRD / 0001

Wash thoroughly after handling.
 Wash contaminated clothing before reuse.
 Drain or remove substance from equipment prior to break-in or maintenance.
 Handle in accordance with good industrial hygiene and safety practice.

Conditions for safe storage : Store locked up.
 Keep container tightly closed in a dry and well-ventilated place.
 Keep in a cool place away from oxidizing agents.

SECTION 8. EXPOSURE CONTROLS/PERSONAL PROTECTION**Components with workplace control parameters**

Components	CAS-No.	Value type (Form of exposure)	Control parameters / Permissible concentration	Basis
Tributyl phosphate	126-73-8	TWA (Inhalable fraction and vapor)	5 mg/m ³	ACGIH
		TWA	0.2 ppm 2.5 mg/m ³	NIOSH REL
		TWA	5 mg/m ³	OSHA Z-1
		TWA	0.2 ppm 2.5 mg/m ³	OSHA P0
Dibutylphenylphosphate	2528-36-1	TWA	0.3 ppm	ACGIH
butylated hydroxytoluene	128-37-0	TWA (Inhalable fraction and vapor)	2 mg/m ³	ACGIH
		TWA	10 mg/m ³	NIOSH REL
		TWA	10 mg/m ³	OSHA P0

Hazardous components without workplace control parameters

Components	CAS-No.
7-Oxabicyclo[4.1.0]heptane-3-carboxylic acid, 2-ethylhexyl ester	62256-00-2

Engineering measures : Good general ventilation (typically 10 air changes per hour) should be used. Ventilation rates should be matched to conditions. If applicable, use process enclosures, local exhaust ventilation, or other engineering controls to maintain airborne levels below recommended exposure limits. If exposure limits have not been established, maintain airborne levels to an acceptable level.

Personal protective equipment

Respiratory protection : Use a properly fitted, particulate filter respirator complying with an approved standard if a risk assessment indicates this is necessary.

Skydrol® LD4 Fire Resistant Hydraulic Fluid

Version	Revision Date:	SDS Number:	Date of last issue: 06/02/2015
2.2	08/09/2016	150000093409	Date of first issue: 10/24/2013

SDSUS / PRD / 0001

Respirator selection, use, and maintenance must be in accordance with regulatory requirements, if applicable. If engineering controls do not maintain airborne concentrations below recommended exposure limits (where applicable) or to an acceptable level (in countries where exposure limits have not been established), an approved respirator must be worn.

Hand protection

Remarks : Wear suitable gloves. Please observe the instructions regarding permeability and breakthrough time which are provided by the supplier of the gloves. Also take into consideration the specific local conditions under which the product is used, such as the danger of cuts, abrasion, and the contact time. After contamination with product change the gloves immediately and dispose of them according to relevant national and local regulations.

Eye protection : Wear safety glasses with side shields (or goggles).

Skin and body protection : Wear suitable protective clothing.

Protective measures : Ensure that eye flushing systems and safety showers are located close to the working place.

SECTION 9. PHYSICAL AND CHEMICAL PROPERTIES

Appearance	: oily
Colour	: purple
Odour	: odourless
pH	: No data available
Melting point/range	: < -62 °C
Flash point	: 160 °C Method: Cleveland open cup
Vapour pressure	: 0.27 hPa (25 °C)
Relative density	: 1.004 - 1.014 (25 °C)
Viscosity	
Viscosity, kinematic	: < 2000 mm ² /s (-54 °C)
	11.15 mm ² /s (38 °C)
	3.83 mm ² /s (99 °C)

Skydrol® LD4 Fire Resistant Hydraulic Fluid

Version 2.2 Revision Date: 08/09/2016 SDS Number: 150000093409 Date of last issue: 06/02/2015
Date of first issue: 10/24/2013
SDSUS / PRD / 0001

Acute oral toxicity : Acute toxicity estimate (Rat, Male and Female): 2,400 - 3,000 mg/kg
Assessment: Not classified

Acute inhalation toxicity : LCLo (Rat, Male and Female): > 5 mg/l
Exposure time: 4 h
Test atmosphere: dust/mist

LC50 (Rat, Male and Female): > 5 mg/l
Exposure time: 4 h
Test atmosphere: dust/mist
Assessment: Not classified

Acute dermal toxicity : LD50 Dermal (Rabbit, Male and Female): > 5,000 mg/kg
Assessment: Not classified

7-Oxabicyclo[4.1.0]heptane-3-carboxylic acid, 2-ethylhexyl ester:

Acute oral toxicity : LD50 Oral (Rat, Male and Female): 4,470 mg/kg

Acute dermal toxicity : LD50 Dermal (Rabbit, Male and Female): > 7,940 mg/kg

butylated hydroxytoluene:

Acute oral toxicity : LD50 Oral (Rat): > 6,000 mg/kg

Acute dermal toxicity : LD50 Dermal (Guinea pig): > 20,000 mg/kg

Skin corrosion/irritation

Causes skin irritation.

Product:

Species: Rabbit
Exposure time: 24 h
Assessment: irritating
Result: moderate irritation

Components:**Tributyl phosphate:**

Species: Rabbit
Exposure time: 4 h
Assessment: Causes skin irritation.
Method: Acute Dermal Irritation / Corrosion
Result: irritating

Dibutylphenylphosphate:

Species: Rabbit
Assessment: Not classified

Species: Humans
Exposure time: 24 h
Assessment: Not classified

7-Oxabicyclo[4.1.0]heptane-3-carboxylic acid, 2-ethylhexyl ester:

Species: Rabbit

Skydrol® LD4 Fire Resistant Hydraulic Fluid

Version 2.2 Revision Date: 08/09/2016 SDS Number: 150000093409 Date of last issue: 06/02/2015
Date of first issue: 10/24/2013
SDSUS / PRD / 0001

Exposure time: 24 h
Assessment: Not classified as hazardous.
Result: slight to moderate irritation

butylated hydroxytoluene:

Species: Rabbit
Exposure time: 24 h
Result: very slight

Serious eye damage/eye irritation

Not classified based on available information.

Product:

Species: Rabbit
Result: slight
Exposure time: 24 h
Assessment: Not classified

Components:**Tributyl phosphate:**

Species: Rabbit
Result: slight irritation
Exposure time: 24 h
Assessment: Not classified
Method: Acute Eye Irritation / Corrosion

Dibutylphenylphosphate:

Species: Rabbit
Result: slight
Assessment: Not classified

7-Oxabicyclo[4.1.0]heptane-3-carboxylic acid, 2-ethylhexyl ester:

Species: Rabbit
Result: slight irritation
Exposure time: 24 h
Assessment: Not classified

butylated hydroxytoluene:

Species: Rabbit
Result: none

Respiratory or skin sensitisation

Skin sensitisation: Not classified based on available information.
Respiratory sensitisation: Not classified based on available information.

Product:

Test Type: Human experience
Assessment: Not classified
Method: Human Repeat Insult Patch Test
Result: Does not cause skin sensitisation.

Components:

Skydrol® LD4 Fire Resistant Hydraulic Fluid

Version 2.2 Revision Date: 08/09/2016 SDS Number: 150000093409 Date of last issue: 06/02/2015
Date of first issue: 10/24/2013
SDSUS / PRD / 0001

Tributyl phosphate:

Test Type: Skin Sensitization
Species: Guinea pig
Assessment: Not classified
Result: Does not cause skin sensitisation.

Test Type: Skin Sensitization
Species: Humans
Assessment: Not classified
Result: Does not cause skin sensitisation.

Dibutylphenylphosphate:

Test Type: Human experience
Species: Humans
Assessment: Not classified
Result: non-sensitizing

7-Oxabicyclo[4.1.0]heptane-3-carboxylic acid, 2-ethylhexyl ester:

Test Type: Skin Sensitization
Species: Guinea pig
Result: May cause sensitisation by skin contact.

butylated hydroxytoluene:

Test Type: Skin sensitisation
Species: Guinea pig
Result: non-sensitizing

Germ cell mutagenicity

Not classified based on available information.

Product:

Genotoxicity in vitro : Test Type: Salmonella typhimurium assay (Ames test)
Metabolic activation: +/- activation
Result: negative

: Test Type: Mutagenicity - Mammalian
Metabolic activation: +/- activation
Method: In vitro Mammalian Chromosome Aberration Test
Result: negative

Components:**Tributyl phosphate:**

Genotoxicity in vitro : Test Type: Mutagenicity - Bacterial
Metabolic activation: +/- activation
Method: Bacterial Reverse Mutation Assay
Result: negative

: Test Type: Mutagenicity - Mammalian
Metabolic activation: +/- activation
Method: In vitro Mammalian Chromosome Aberration Test
Result: equivocal

Genotoxicity in vivo : Species: Rat (Male and Female)

Skydrol® LD4 Fire Resistant Hydraulic Fluid

Version Revision Date: SDS Number: Date of last issue: 06/02/2015
 2.2 08/09/2016 150000093409 Date of first issue: 10/24/2013
 SDSUS / PRD / 0001

Application Route: oral: gavage
 Method: Mammalian Bone Marrow Chromosome Aberration Test
 Result: negative

Dibutylphenylphosphate:

Genotoxicity in vitro

: Test Type: Salmonella typhimurium assay (Ames test)
 Metabolic activation: +/- activation
 Method: Bacterial Reverse Mutation Assay
 Result: negative

: Test Type: Mutagenicity - Mammalian
 Metabolic activation: +/- activation
 Method: In vitro Mammalian Cell Gene Mutation Test
 Result: negative

: Test Type: Chromosome aberration test in vitro
 Metabolic activation: +/- activation
 Method: In vitro Mammalian Chromosome Aberration Test
 Result: negative

: Test Type: Mutagenicity - Mammalian
 Metabolic activation: - activation
 Method: Genetic Toxicology: DNA Damage and Repair, Un-scheduled DNA Synthesis in Mammalian Cells In Vitro
 Result: negative

Genotoxicity in vivo

: Species: Rat (Male and Female)
 Application Route: intraperitoneal injection
 Result: negative

7-Oxabicyclo[4.1.0]heptane-3-carboxylic acid, 2-ethylhexyl ester:

Genotoxicity in vitro

: Test Type: Salmonella typhimurium assay (Ames test)
 Metabolic activation: +/- activation
 Method: Bacterial Reverse Mutation Assay
 Result: negative

: Test Type: Mutagenicity - Mammalian
 Metabolic activation: +/- activation
 Method: In vitro Mammalian Chromosome Aberration Test
 Result: equivocal

: Test Type: Mutagenicity - Mammalian
 Metabolic activation: +/- activation
 Method: In vitro Mammalian Cell Gene Mutation Test
 Result: negative

Genotoxicity in vivo

: Species: Rat (Male and Female)
 Application Route: intraperitoneal injection
 Method: Mammalian Bone Marrow Chromosome Aberration Test
 Result: equivocal

Skydrol® LD4 Fire Resistant Hydraulic Fluid

Version Revision Date: SDS Number: Date of last issue: 06/02/2015
 2.2 08/09/2016 150000093409 Date of first issue: 10/24/2013
 SDSUS / PRD / 0001

Carcinogenicity

Suspected of causing cancer.

Components:**Tributyl phosphate:**

Species: Rat, (Male and Female)
 Application Route: Ingestion
 Method: EPA OTS 798.3300
 Remarks: Limited evidence of a carcinogenic effect.
 May cause cancer.

IARC

No component of this product present at levels greater than or equal to 0.1% is identified as probable, possible or confirmed human carcinogen by IARC.

OSHA

No component of this product present at levels greater than or equal to 0.1% is identified as a carcinogen or potential carcinogen by OSHA.

NTP

No component of this product present at levels greater than or equal to 0.1% is identified as a known or anticipated carcinogen by NTP.

Reproductive toxicity

Not classified based on available information.

Components:**Tributyl phosphate:**

Effects on fertility :
 : Test Type: Two Generation Reproductive Toxicity Study
 Species: Rat
 Sex: Male and Female
 Application Route: Ingestion
 NOAEL: 225 mg/kg,
 Method: EPA OTS 798.4900

Effects on foetal development : Species: Rat
 Application Route: Oral
 750 mg/kg
 Method: EPA OTS 798.4900

Dibutylphenylphosphate:

Effects on fertility :
 : Species: Rat
 Sex: Male and Female
 Application Route: Ingestion
 NOAEL: 5 mg/l,
 F1: Lowest observed adverse effect level 50 mg/kg,
 F2: Lowest observed adverse effect level 50 mg/kg,
 Method: EPA OTS 798.4900

Effects on foetal development : Species: Rat
 Application Route: oral (gavage)

Skydrol® LD4 Fire Resistant Hydraulic Fluid

Version 2.2 Revision Date: 08/09/2016 SDS Number: 150000093409 Date of last issue: 06/02/2015
Date of first issue: 10/24/2013
SDSUS / PRD / 0001

300 mg/kg
3 mg/kg

STOT - single exposure

Not classified based on available information.

Components:**Tributyl phosphate:**

Assessment: Based on available data, the classification criteria are not met.

Dibutylphenylphosphate:

Assessment: Not classified

STOT - repeated exposure

Not classified based on available information.

Components:**Tributyl phosphate:**

Assessment: Based on available data, the classification criteria are not met.

Dibutylphenylphosphate:

Exposure routes: inhalation (dust/mist/fume)

Target Organs: Respiratory system

Assessment: Not classified

Repeated dose toxicity**Product:**

Species: Rat, Male and Female

NOAEL: 40 mg/m³

Application Route: Inhalation

Exposure time: 28 days

Target Organs: Blood, Respiratory system

Remarks: Irritating to eyes and respiratory system.

Components:**Tributyl phosphate:**

Species: Mouse, Male and Female

NOEL: 75 mg/kg

Application Route: in feed

Exposure time: 90 days

Dibutylphenylphosphate:

Species: Rat, Male and Female

NOAEL: 5 mg/kg

LOAEL: 50 mg/kg

Application Route: oral (feed)

Exposure time: 90 days

Species: Rat, Male and Female

NOAEC: 5 mg/m³

Application Route: Inhalation

Skydrol® LD4 Fire Resistant Hydraulic Fluid

Version 2.2 Revision Date: 08/09/2016 SDS Number: 150000093409 Date of last issue: 06/02/2015
 Date of first issue: 10/24/2013
 SDSUS / PRD / 0001

aquatic invertebrates	Exposure time: 48 h
Toxicity to algae	: EC50 (Desmodesmus subspicatus (Scenedesmus subspicatus)): 1.1 mg/l Exposure time: 72 h
Toxicity to fish (Chronic toxicity)	: NOEC (Oncorhynchus mykiss (rainbow trout)): 0.82 mg/l Exposure time: 95 d 1.7 mg/l
Toxicity to daphnia and other aquatic invertebrates (Chronic toxicity)	: NOEC (Daphnia magna (Water flea)): 1.3 mg/l Exposure time: 21 d
Dibutylphenylphosphate:	
Toxicity to fish	: LL50 (Cyprinus carpio (Carp)): 1.8 mg/l Exposure time: 96 h
Toxicity to daphnia and other aquatic invertebrates	: EC50 (Daphnia magna (Water flea)): 1.4 mg/l Exposure time: 48 h
Toxicity to algae	: EL50 (Selenastrum capricornutum (green algae)): 9.6 mg/l Exposure time: 72 h Method: EL50 method of the water accommodated fraction (W.A.F.) NOELR (Selenastrum capricornutum (green algae)): 3.5 mg/l Exposure time: 72 h Method: EL50 method of the water accommodated fraction (W.A.F.)
Toxicity to fish (Chronic toxicity)	: NOEC (Oncorhynchus mykiss (rainbow trout)): > 0.11 mg/l Exposure time: 60 d
Toxicity to daphnia and other aquatic invertebrates (Chronic toxicity)	: NOEC (Daphnia magna (Water flea)): 0.106 mg/l Exposure time: 21 d
butylated hydroxytoluene:	
Toxicity to fish	: LC50 (Fish): 0.199 mg/l Exposure time: 96 h
Toxicity to daphnia and other aquatic invertebrates	: EC50 (Daphnia (water flea)): 0.48 mg/l Exposure time: 48 h
Toxicity to algae	: EC50 (Chlorella pyrenoidosa (aglae)): 0.758 mg/l Exposure time: 96 h

Persistence and degradability**Product:**

Biochemical Oxygen Demand (BOD) : Remarks: not determined

Skydrol® LD4 Fire Resistant Hydraulic Fluid

Version 2.2 Revision Date: 08/09/2016 SDS Number: 150000093409 Date of last issue: 06/02/2015
Date of first issue: 10/24/2013
SDSUS / PRD / 0001

Chemical Oxygen Demand (COD) : Remarks: not determined

Components:**Tributyl phosphate:**

Biodegradability : Result: Readily biodegradable

Dibutylphenylphosphate:

Biodegradability : Method: Ready Biodegradability: Manometric Respirometry Test

Remarks: Readily biodegradable

Method: Ready Biodegradability: Modified MITI Test (I)

Remarks: Not readily biodegradable.

7-Oxabicyclo[4.1.0]heptane-3-carboxylic acid, 2-ethylhexyl ester:

Biodegradability : Concentration: 100 mg/l
Method: Ready Biodegradability: Modified MITI Test (I)
Remarks: Readily biodegradable

Bioaccumulative potential**Components:****Tributyl phosphate:**

Bioaccumulation : Species: Cyprinus carpio (Carp)
Bioconcentration factor (BCF): 20
Exposure time: 56 d
Method: OECD Test Guideline 305

Bioconcentration factor (BCF): 35

Exposure time: 38 d

Partition coefficient: n-octanol/water : Pow: 10,100

Dibutylphenylphosphate:

Bioaccumulation : Species: Cyprinus carpio (Carp)
Bioconcentration factor (BCF): 35
Method: OECD Test Guideline 305

Mobility in soil

No data available

Other adverse effects**Product:**

Ozone-Depletion Potential :

Regulation: 40 CFR Protection of Environment; Part 82 Protection of Stratospheric Ozone - CAA Section 602 Class I Substances

Skydrol® LD4 Fire Resistant Hydraulic Fluid

Version Revision Date: SDS Number: Date of last issue: 06/02/2015
2.2 08/09/2016 15000093409 Date of first issue: 10/24/2013
SDSUS / PRD / 0001

Remarks: This product neither contains, nor was manufactured with a Class I or Class II ODS as defined by the U.S. Clean Air Act Section 602 (40 CFR 82, Subpt. A, App.A + B).

SECTION 13. DISPOSAL CONSIDERATIONS**Disposal methods**

Waste from residues : This product meets the criteria for a synthetic used oil under the U.S. EPA Standards for the Management of Used Oil (40 CFR 279). Those standards govern recycling and disposal in lieu of 40 CFR 260 -272 of the Federal hazardous waste program in states that have adopted these used oil regulations. Consult your attorney or appropriate regulatory official to be sure these standards have been adopted in your state. Recycle or burn in accordance with the applicable standards. Dispose of in accordance with local regulations.

SECTION 14. TRANSPORT INFORMATION**International Regulation****IATA-DGR**

Not regulated as a dangerous good

IMDG-Code

Not regulated as a dangerous good

Transport in bulk according to Annex II of MARPOL 73/78 and the IBC Code

Not applicable for product as supplied.

National Regulations**49 CFR**

Not regulated as a dangerous good

SECTION 15. REGULATORY INFORMATION**EPCRA - Emergency Planning and Community Right-to-Know Act****SARA 311/312 Hazards**

: Acute Health Hazard
Chronic Health Hazard

SARA 302

: No chemicals in this material are subject to the reporting requirements of SARA Title III, Section 302.

SARA 313

: This material does not contain any chemical components with known CAS numbers that exceed the threshold (De Minimis) reporting levels established by SARA Title III, Section 313.

Clean Air Act

Skydrol® LD4 Fire Resistant Hydraulic Fluid

Version Revision Date: SDS Number: Date of last issue: 06/02/2015
 2.2 08/09/2016 150000093409 Date of first issue: 10/24/2013
 SDSUS / PRD / 0001

Association; IBC - International Code for the Construction and Equipment of Ships carrying Dangerous Chemicals in Bulk; IC50 - Half maximal inhibitory concentration; ICAO - International Civil Aviation Organization; IECSC - Inventory of Existing Chemical Substances in China; IMDG - International Maritime Dangerous Goods; IMO - International Maritime Organization; ISHL - Industrial Safety and Health Law (Japan); ISO - International Organisation for Standardization; KECI - Korea Existing Chemicals Inventory; LC50 - Lethal Concentration to 50 % of a test population; LD50 - Lethal Dose to 50% of a test population (Median Lethal Dose); MARPOL - International Convention for the Prevention of Pollution from Ships; MSHA - Mine Safety and Health Administration; n.o.s. - Not Otherwise Specified; NFPA - National Fire Protection Association; NO(A)EC - No Observed (Adverse) Effect Concentration; NO(A)EL - No Observed (Adverse) Effect Level; NOELR - No Observable Effect Loading Rate; NTP - National Toxicology Program; NZIoC - New Zealand Inventory of Chemicals; OECD - Organization for Economic Co-operation and Development; OPPTS - Office of Chemical Safety and Pollution Prevention; PBT - Persistent, Bioaccumulative and Toxic substance; PICCS - Philippines Inventory of Chemicals and Chemical Substances; (Q)SAR - (Quantitative) Structure Activity Relationship; RCRA - Resource Conservation and Recovery Act; REACH - Regulation (EC) No 1907/2006 of the European Parliament and of the Council concerning the Registration, Evaluation, Authorisation and Restriction of Chemicals; RQ - Reportable Quantity; SADT - Self-Accelerating Decomposition Temperature; SARA - Superfund Amendments and Reauthorization Act; SDS - Safety Data Sheet; TCSI - Taiwan Chemical Substance Inventory; TSCA - Toxic Substances Control Act (United States); UN - United Nations; UNRTDG - United Nations Recommendations on the Transport of Dangerous Goods; vPvB - Very Persistent and Very Bioaccumulative

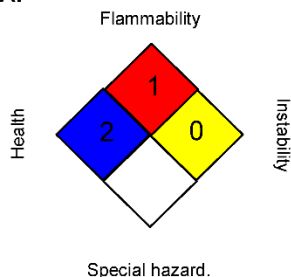
Further information**NFPA:****HMIS III:**

HEALTH	2*
FLAMMABILITY	1
PHYSICAL HAZARD	0

0 = not significant, 1 = Slight,
 2 = Moderate, 3 = High
 4 = Extreme, * = Chronic

Sources of key data used to compile the Safety Data Sheet : www.EastmanAviationSolutions.com
 Revision Date : 08/09/2016

The information provided in this Safety Data Sheet is correct to the best of our knowledge, information and belief at the date of its publication. The information given is designed only as a guidance for safe handling, use, processing, storage, transportation, disposal and release and is not to be considered a warranty or quality specification. The information relates only to the specific material designated and may not be valid for such material used in combination with any other materials or in any process, unless specified in the text.



APPENDIX IV

Instrument Certification Notice



Instrument Certification Notice

The gauge Certificates of Calibration supplied for the gauge(s) on this unit contain the calibration data for the actual instrument calibrated, along with the calibration date of the **STANDARD** used to perform the calibration check.

The due date for re-calibration of the instrument should be based upon the date the instrument was placed in service in your facility. Re-calibration should be done on a periodic basis as dictated by the end user's quality system or other overriding requirements.

Note that Tronair, Inc. does not supply certificates of calibration on flow meters or pyrometers unless requested at the time of placed order. These instruments are considered reference indicators only and are not critical to the test(s) being performed on the aircraft.