

**57X1 Series
5711, 5721, 5731, 5751
Hydraulic Power Units**



06/2026 – Rev. 14

For Spare Parts, Operations & Service Manuals or Service Needs
Scan the QR code or visit tronair.com/pages/tronair-information-center



The Tronair Group of Companies: Tronair | Columbus Jack | Eagle | Malabar International

Tronair, Inc.
1 Air Cargo Pkwy East
Swanton, OH 43558

Phone: (419) 866-6301 | 800-426-6301
Web: www.tronair.com
Email: sales@tronair.com

REVISION	DATE	TEXT AFFECTED
01	11/2016	Original Release
02	03/2017	Modified 9.13.12 Return Sight Gauge (Option U) and 9.13.13 Return Sight Gauge (Option Y)
03	12/2017	Modified 9.2 Electric Motor
04	04/2019	Modified 9.13.14 & 9.13.15
05	11/2019	Modified 9.12
06	03/2020	Modified 9.10.1
07	08/2021	Added section 5.12 Infrequent HPU Use and updated 9.0 Maintenance
08	05/2024	Modified 9.13.7 High Displacement Hand Pump (Option 7)
09	10/2024	Modified 9.13.7 High Displacement Hand Pump (Option 7)
10	11/2024	Modified 9.9 Return Manifold Assembly, 9.3 Split System (Option C), 9.13.2 Split System (Option C), 9.13.12 Return Sight Gauge (<i>Option U</i>), 9.13.13 Split System Return Sight Gauge (<i>Option Y</i>), 9.13.14 Return Backpressure (<i>Option V</i>)
11	01/2025	Added model 5751
12	05/2025	Modified 9.13.15 Drip Pan (Option 4)
13	03/2026	Major revision
14	06/2026	Modified 9.13 Electrical Components

TABLE OF CONTENTS

PAGE

1.0	PRODUCT INFORMATION	1
1.1	DESCRIPTION	1
1.2	MODEL & SERIAL NUMBER	1
1.3	MANUFACTURER	1
1.4	FUNCTION	1
1.5	REQUIREMENTS	1
2.0	SAFETY INFORMATION	2
2.1	USAGE AND SAFETY INFORMATION	2
2.2	EXPLANATION OF WARNING & DANGER SIGNS	2
2.3	COMPONENT SAFETY FEATURES	2
2.4	FUNCTIONAL SAFETY FEATURES	2
2.5	PERSONAL PROTECTION EQUIPMENT	2
2.6	SAFETY GUIDELINES	2
2.7	GENERAL COMMENT	2
3.0	PREPARATION PRIOR TO FIRST USE	3
3.1	GENERAL	3
3.2	SERVICING RESERVOIR	3
3.3	CONNECTING ELECTRICAL LEADS	3
4.0	TRAINING	3
4.1	TRAINING REQUIREMENTS	3
4.2	TRAINING PROGRAM	3
4.3	OPERATOR TRAINING	3
5.0	OPERATION	4
5.1	OPERATING PARAMETERS	4
5.2	NUMERICAL VALUES	4
5.2.1	Hydraulic Power Unit	4
5.2.2	Physical	4
5.2.3	Hydraulic Pump	5
5.2.4	Electric Motor	5
5.2.5	Filters	5
5.2.6	Hand Pump (<i>Option M</i>)	5
5.2.7	Hand Pump (<i>Option M-7</i>)	5
5.2.8	Hand Pump (<i>Option M-E & M-F electric fill pump</i>)	6
5.3	LOCATION & LAYOUT OF CONTROLS	6
5.3.1	Front Panel Controls	6
5.3.2	Electrical Control Panel	7
5.3.3	Hydraulic Control Panel	8
5.3.4	Rear Panel Controls	9
5.3.5	Hydraulic Pump Controls	10
5.3.6	Hand Pump Controls (<i>Option M</i>)	11
5.3.7	Split System Controls (<i>Option C</i>)	12
5.4	START UP PROCEDURES	13
5.4.1	Procedure for First Time or Different Electrical Supply ONLY	13
5.4.2	Initial Start Up of the HPU	13
5.5	PRELIMINARY ADJUSTMENTS FOR OPERATION	13
5.5.1	Flow Control Adjustment	13
5.5.2	Pressure Control Adjustment	14
5.5.3	Reservoir Selector Valve Operation	14
5.5.4	Bypass Valve Operation	14
5.6	BLEEDING AIR FROM SYSTEM	14
5.6.1	To Easily Purge the Unit of Air	15
5.7	SPLIT SYSTEM OPERATION (<i>Option C</i>)	15
5.7.1	To Operate the Split System	15
5.8	HAND PUMP OPERATION	15
5.8.1	Hand Pump Operation (<i>Option M</i>)	15
5.8.2	Hand Pump Operation (<i>Option M-7</i>)	16
5.8.3	Electric Fill Pump/Drain Operation (<i>Option M-E and M-F</i>)	16
5.9	SAMPLE VALVE	16
5.10	EMERGENCY SHUT DOWN PROCEDURE	16
5.11	DESCRIPTION OF ALARM SYSTEMS	16
5.11.1	High Fluid Temperature Indicator	16
5.11.2	Voltage/Phase Monitor Indicator	16
5.11.3	High and Low Reservoir Level Indicator (<i>Option L</i>)	16
5.11.4	Clogged Filter Indicator Light	17
5.11.5	Contamination Monitor (<i>Option CM</i>)	17

5.12	INFREQUENT HPU USE	17
5.12.1	Infrequent HPU Use Start Up Procedure	17
6.0	PACKAGING AND STORAGE	18
6.1	PACKAGING REQUIREMENTS	18
6.2	HANDLING	18
6.3	PACKAGING PROTECTION	18
6.4	LABELING OF PACKAGING	18
6.5	STORAGE COMPATIBILITY	18
6.6	STORAGE ENVIRONMENT	18
6.7	STORAGE SPACE AND HANDLING FACILITIES	18
7.0	TRANSPORTATION	18
8.0	TROUBLE SHOOTING	19
8.1	HPU WILL NOT START	19
8.2	NO FLOW	19
8.3	REDUCED FLOW	20
8.4	NO PRESSURE or REDUCED PRESSURE	20
8.5	FLUID OVERHEATS	20
8.6	HAND PUMP (<i>Option M or M-7</i>) IS NOT PUMPING FLUID	20
9.0	MAINTENANCE	21
9.1	GENERAL	21
9.2	DISPOSAL OF FLUIDS	21
9.3	DISMANTLING OF THE UNIT	21
9.3.1	Key Procedures for Dismantling Industrial Equipment	21
9.4	COMPONENT SERVICING	22
9.4.1	Pump Replacement	22
9.4.2	PRV Setting	23
9.4.3	Flowmeter Replacement	24
9.4.4	Pressure Gauge Replacement	25
9.4.5	Pyrometer Replacement	26
9.4.6	Noise Suppressor Servicing	27
9.5	ELECTRIC MOTOR	28
9.6	MOTOR DRIVEN HYDRAULIC PUMP	29
9.7	HYDRAULIC FLUID	29
9.8	FILTERS	29
9.8.1	Pressure Filter Element	30
9.8.2	Return Filter Element	31
9.8.3	Hand Pump (<i>Options M, M-7 and Electric Fill</i>) Filter Element	32
9.8.4	Desiccant Air Filter	33
9.8.5	Pressure Filter Assembly	34
9.8.6	Return Filter Assembly	35
9.9	HYDRAULIC HOSES	36
9.10	INSTRUMENT PANEL	39
9.10.1	Electric Panel	39
9.10.2	Hydraulic Panel	41
9.10.3	Flowmeter Manifold Assembly	43
9.10.4	Flow Control Assembly	45
9.10.5	Pressure Control Assembly	46
9.10.6	Replacement Valves	47
9.10.6.a	System Pressure Relief Valve	47
9.10.6.b	Check Valve	48
9.10.6.c	Bypass Valve	49
9.11	RESERVOIR ASSEMBLY	50
9.12	RETURN MANIFOLD ASSEMBLY	53
9.12.1	Return System Pressure Relief Valve	55
9.13	ELECTRICAL COMPONENTS	56
9.14	HEAT EXCHANGER ASSEMBLY	62
9.15	EXTERNAL COMPONENTS	63
9.16	ADDITIONAL FEATURES	64
9.16.1	50 ft (15.2 m) Hoses (<i>Option B</i>)	64
9.16.2	Split System (<i>Option C</i>)	65
9.16.3	Pyrometer	66
9.16.4	Electric Reservoir Level (<i>Option L</i>)	67
9.16.5	Hand Pump (<i>Option M</i>)	68
9.16.6	Hand Pump High Displacement (<i>Option M-7</i>)	71
9.16.7	Electric Fill Pump (<i>Option M-E and M-F</i>)	74
9.16.8	Towing Trailer (<i>Option N</i>)	79
9.16.9	Stack Light (<i>Option SL</i>)	80
9.16.10	Return Sight Gauge (<i>Option U</i>)	81
9.16.11	Split System Return Sight Gauge (<i>Option Y</i>)	82

9.16.12	Return Backpressure (<i>Option V</i>).....	83
9.16.13	Drip Pan (<i>Option 4</i>).....	84
9.16.14	Contamination Monitor.....	85
9.17	REPLACEMENT LABELS PARTS LISTS	87
9.17.1	Base Unit.....	87
9.17.2	Fluid Labels	87
9.17.3	Filter Element Kit Labels.....	88
9.17.4	Split System (<i>Option C</i>)	88
9.17.5	Hand Pump (<i>Option M</i>) Labels	88
10.0	PROVISION OF SPARES.....	89
10.1	SOURCE OF SPARE PARTS	89
10.2	RECOMMENDED SPARE PARTS LISTS.....	89
11.0	CALIBRATION OF INSTRUMENTATION	90
11.1	SOURCE OF CALIBRATION	90
12.0	IN SERVICE SUPPORT.....	90
13.0	GUARANTEES/LIMITATION OF LIABILITY	90
14.0	APPENDICES	90

This product can not be modified without the written approval of Tronair, Inc. Any modifications done without written approval voids all warranties and releases Tronair, Inc., its suppliers, distributors, employees, or financial institutions from any liability from consequences that may occur. Only Tronair OEM replacement parts shall be used.

1.0 PRODUCT INFORMATION

1.1 DESCRIPTION

Hydraulic Power Unit

Model Number	Fluid Type
5711	MIL-PRF-5606
5721	MIL-PRF-83282
5731	Aviation Phosphate Ester, Skydrol
5751	Aviation Phosphate Ester, HyJet

1.2 MODEL & SERIAL NUMBER

Reference nameplate on unit.

1.3 MANUFACTURER

TRONAIR , Inc.	Telephone: (419) 866-6301 or 800-426-6301
1 Air Cargo Pkwy East	Fax: (419) 867-0634
Swanton, Ohio 43558 USA	E-mail: sales@tronair.com
	Website: www.tronair.com

Primary Cage Code.....59603

1.4 FUNCTION

The Hydraulic Power Unit (HPU) provides a source of clean, pressurized hydraulic fluid for performing required aircraft maintenance. An electric motor drives a pressure compensated load sense pump. Filters are provided on the pressure and return systems. A bypass (dump) valve allows starting and stopping of the unit under a no-load, safe condition. The unit may use either the aircraft or on-board HPU reservoir. Cooling is provided for continuous operation.

1.5 REQUIREMENTS

Adequate electrical power must be provided for proper functioning of the HPU. See the unit nameplate for proper voltage and frequency. See the Technical Manual for proper sizing of electrical supply and protection equipment in the facility.

2.0 SAFETY INFORMATION

2.1 USAGE AND SAFETY INFORMATION

The HPU provides pressurized hydraulic fluid for performing aircraft maintenance.

To ensure safe operations please read the following statements and understand their meaning. Also refer to your equipment manufacturer's manual for other important safety information. This manual contains safety precautions which are explained below. Please read carefully.



WARNING! — Warning is used to indicate the presence of a hazard that **can cause severe personal injury, death, or substantial property damage** if the warning notice is ignored.

CAUTION! — Caution is used to indicate the presence of a hazard that **will or can cause minor personal injury or property damage** if the caution notice is ignored.

2.2 EXPLANATION OF WARNING & DANGER SIGNS



Accidental Starts! Before servicing the HPU or equipment, always disconnect electrical power supply to prevent accidental starting.



Rotating Parts! Keep hands, feet, hair, and clothing away from all moving parts to prevent injury. Never operate the HPU with covers, shrouds, or guards removed.



Electrical Shock! Never touch electrical wires or components while the HPU is attached to the power source. They can be sources of electrical shock. **DO NOT** operate HPU with cabinet panels removed.



Pressurized Fluid! Before servicing the HPU or equipment, always open the bypass valve to relieve any residual pressure in the hydraulic system.



Nitrogen Safety! Safely handling high-pressure nitrogen requires preventing asphyxiation, avoiding cylinder damage, and using proper PPE. Ensure adequate ventilation to prevent oxygen depletion (below 19.5% is dangerous), secure cylinders upright, use pressure-regulated equipment, and wear safety glasses, gloves, and protective clothing to avoid cold burns

2.3 COMPONENT SAFETY FEATURES

- Pump/Motor coupling guard
- Sheet metal panels
- Pressure and return system relief valves
- Control circuit fuses or breakers
- Motor overload protection
- Branch circuit protection

2.4 FUNCTIONAL SAFETY FEATURES

- Emergency shut off switch
- Floor lock
- Calibration fitting safety cap
- Fluid sample shut off valve

2.5 PERSONAL PROTECTION EQUIPMENT

- Safety glasses must be worn when operating the HPU.
- Additional equipment recommended by the fluid manufacturer (gloves, etc.). **Reference Appendix pertaining to Safety Data Sheet pertaining to fluid(s).**

2.6 SAFETY GUIDELINES

- Operator must be properly trained prior to operating the HPU.
- HPU power switch must be in "Off" position when connecting or disconnecting hoses to the aircraft.
- Bypass valve must be in the "Open" position when starting or stopping the HPU.
- Electrical power must be disconnected from the HPU and the bypass valve must be in the "Open" position before servicing the HPU. (Reference Technical Manual for details on servicing the HPU.)
- Fire extinguisher required for electrical and hydraulic fire.

2.7 GENERAL COMMENT

The HPU is intended to be operated by personnel trained in the proper use in conjunction with the aircraft maintenance manual.

The HPU must be used in accordance with the Technical and Operator Manuals and the intended aircraft.

3.0 PREPARATION PRIOR TO FIRST USE**3.1 GENERAL**

Prior to operating the HPU, the user should become familiar with this Operator Manual.

3.2 SERVICING RESERVOIR

Fill the reservoir with the correct fluid (see label next to reservoir fill for correct type of fluid) until fluid level is above the minimum fluid level mark but below the maximum fluid level. See 5.3.1 Front Panel Controls for reservoir fill location.

NOTE: Leave the Reservoir Selector Valve in the Aircraft Reservoir position (as shipped) until the Hydraulic Power Unit reservoir has been filled.

3.3 CONNECTING ELECTRICAL LEADS

Electrical Shock! Never touch electrical wires or components while electrical power is attached. Only qualified electricians should connect the electrical leads.

Install plug onto the electrical cord. If motor rotation is not correct, change any two of the three leads at the plug. **Reference 11.0 Electrical Power and Protection Requirements** for power requirements and fuse sizes. (See **5.4 Start up Procedures** before starting HPU.)

**WARNING!**

Balanced three phase voltage must be available to prevent overheating and damage to the motor.

Voltage unbalanced between phases occurs when the voltages differ from one another.

Some reasons for imbalance are:

- 1. Unequal loading of each phase**
- 2. Poor connections in the supply**
- 3. Single phase condition caused by blown fuses or bad connections**

If these conditions occur in the incoming power system, a protective voltage device is installed on the machine to prevent motor damage.

4.0 TRAINING**4.1 TRAINING REQUIREMENTS**

The employer of the operator is responsible for providing a training program sufficient for the safe operation of the HPU.

4.2 TRAINING PROGRAM

The employer provided operator training program should cover safety procedures concerning use of the HPU in and around the intended aircraft at the intended aircraft servicing location.

4.3 OPERATOR TRAINING

The operator training should provide the required training for safe operation of the HPU.

NOTE: Maintenance and Trouble Shooting are to be performed by a skilled and trained technician.

5.0 OPERATION

5.1 OPERATING PARAMETERS

- The user shall use the HPU in accordance with the aircraft manufacturer's instructions.
- The user shall operate the HPU in accordance with the Operation & Service Manual.
- The employer of the operator shall provide all necessary training.
- User is responsible for installing and supplying electrical power that meets the applicable local and national electrical codes.
- The electrical power supply for the HPU must include a fused disconnect using Type J or Type R fuses or equivalent magnetic type circuit breakers designed for protecting an electrical motor. This necessary equipment is for protection of the HPU, power cord, and customer-supplied plug and receptacle. Reference the Table below:

ELECTRICAL POWER AND PROTECTION REQUIREMENTS

60 Hz Applications			
Voltage	380	460	575
Full Load Amps	103.8	92	73.6
Locked Rotor Amps	543	543	413
Recommended Fuse Size	150	125	90
Maximum Fuse Size	150	125	100

50 Hz Applications			
Voltage	380	415	440
Full Load Amps	107	105	92
Locked Rotor Amps	625	582	539
Recommended Fuse Size	150	125	125
Maximum Fuse Size	150	150	125

5.2 NUMERICAL VALUES

5.2.1 Hydraulic Power Unit

Model Number	Fluid Type
5711	MIL-PRF-5606
5721	MIL-PRF-83282
5731	Aviation Phosphate Ester, Skydrol
5751	Aviation Phosphate Ester, HyJet

5.2.2 Physical

Weight (Dry)	3,500 lbs (1,588 kg)
Width	63.75 in (162 cm) Add 7.5 in (19 cm) for Split System
Height	59 in (149.9 cm)
Depth	78 in (198 cm)
Power Cord	50 ft (15.24 m) long Standard Length 100 ft (30.48 m) long Optional Length
Pressure Hoses	25 ft (7.62 m) Standard Length 50 ft (15.24 m) Optional Length -16 (1 in, 25.4 mm) Working Diameter
Return Hoses	25 ft (7.62 m) Standard Length 50 ft (15.24 m) Optional Length -24 (1½ in, 38.1 mm) Working Diameter
Hand Pump Hose	15 ft (4.57 m) Standard Length -6 (3/8 in, 9.53 mm) Working Diameter
Operating Temperature Range	0°-100° F (-18°-38° C)
Sound Level at 3 ft (1 m) from operator panel	78dbA at operating panel
Ingress Protection Rating	IP 62 (dust and falling water)
Fluid Cleanliness	This unit is tested and certified to NAS class 3 or lower before shipping. Supply filter is 2 micron rated and return filter is 5 micron rated

5.2.3 Hydraulic Pump

- A pressure compensated, adjustable maximum volume pressure compensated load sense piston pump.
- Maximum flow at 60 Hz 34 gpm (129 lpm)
- Maximum flow at 50 Hz 28 gpm (107 lpm)
- Maximum operating pressure at 50 Hz and 60 Hz 4,000 psi (276 bar)
- System pressure relief valve setting 4,250 psi (293 bar)
- Performance Curve for 50 Hz and 60 Hz

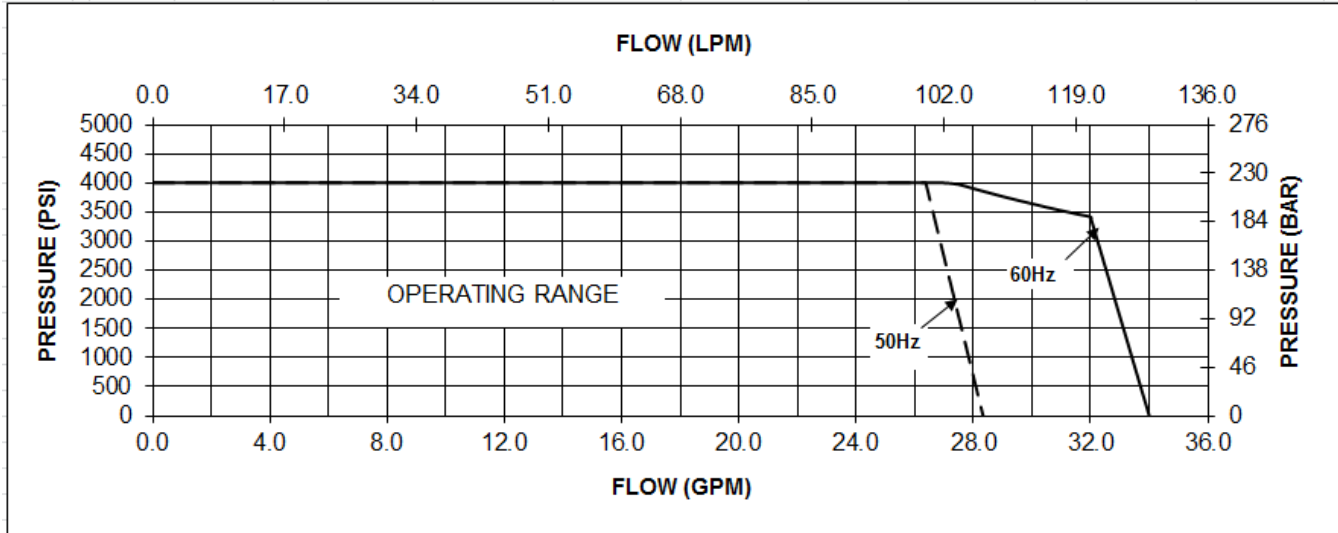

5.2.4 Electric Motor

A 75 horsepower, TEFC electric motor is the prime mover for the HPU. This is attached to the hydraulic pump using a pump/motor adapter and a spider/coupling rotating interface.

See section 5.1 Operating Parameters for motor power requirements.

5.2.5 Filters

- Pressure 2 micron rating, non-bypass high collapse microglass type. Non-cleanable element
- Return 5 micron rating, 25 psi (1.72 bar) bypass microglass type. Non-cleanable element
- Hand Pump (*Option M, M-7, electric fill*) 2 micron rating, non-bypass microglass type. Non-cleanable element
- Air/Desiccant 3 micron filter, silica gel desiccant type. Non-cleanable element
- Reservoir Fill Strainer

5.2.6 Hand Pump (*Option M*)

Two stage hand pump, low pressure stage 0–500 psi (0–34.47 bars) and 500–5,000 psi (34.47–344.74 bars) high pressure stage. Pump automatically changes stage internally based on system pressure.

Low Pressure Stage	Piston Diameter	1-1/2 in (38.1 mm)
	Working Pressure	0–500 psi (0–34.47 bar)
	Displacement/Stroke	2.1 in ³ (34.4 cm ³)
	Force/100 psi (6.89 bar)	12.0 lbs/100 psi (7.74 N/bar)
High Pressure Stage	Piston Diameter	5/8 in (15.88 mm)
	Working Pressure	500–5000 psi (34.47–344.74 bar)
	Displacement/Stroke	0.4 in ³ (6.55 cm ³)
	Force/100 psi (6.89 bar)	2.2 lbs/100 psi (1.42 N/bar)
Pressure Relief Setting		5,250 psi (362.0 bar)

5.2.7 Hand Pump (*Option M-7*)

Piston Diameter	2-1/2 in (63.5 mm)
Working Pressure	0-250 psi (17.2 bar)
Pressure Relief Setting	300 psi (20.7 bar)

- 5.2.8 Hand Pump (*Option M-E & M-F electric fill pump*)
- Electric Fill Pump.....0.2 cu in/rev
 - Motor.....1200 rpm
 - Flow Rate.....1.0 gpm (3.8 lpm) at 60 hz
0.83 gmp (3.1 lpm) at 50 hz
 - Pressure Relief Setting.....70 psi (4.8bar)

5.3 LOCATION & LAYOUT OF CONTROLS

5.3.1 Front Panel Controls

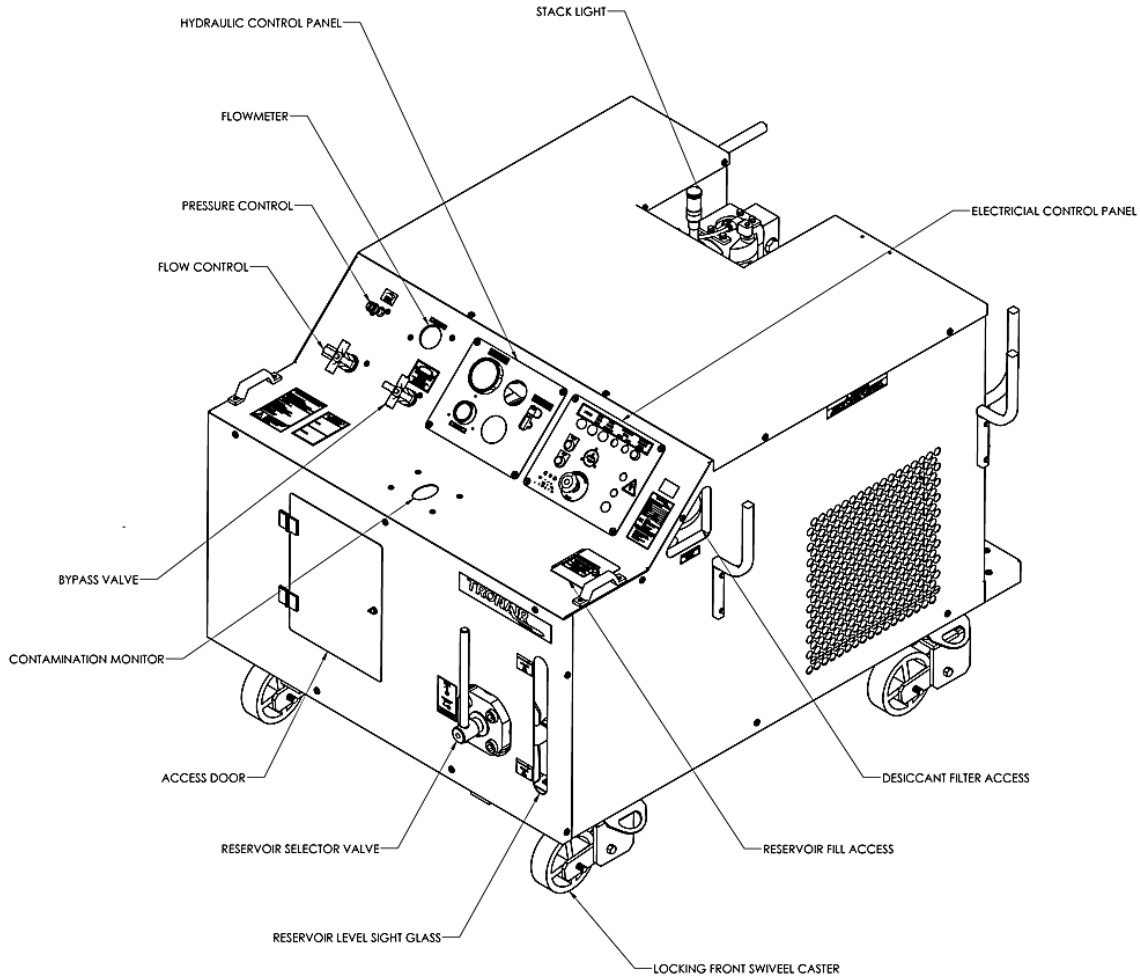

Electrical Control Panel	See Section 5.3.2
Hydraulic Control Panel	See Section 5.3.3
Bypass Valve	For loading and unloading the motor driven hydraulic pump
Contamination Monitor	For reporting fluid cleanliness in NAS1638 format
Flow Control	For setting maximum flow of the pump
Flowmeter	Displays the flow from the motor driven hydraulic pump
Pressure Control	For setting system pressure of the system
Reservoir Selector	For selecting between using the aircraft reservoir or the HPU reservoir
Sight Gauge	Visual indicator displays the fluid level in the reservoir
Reservoir Fill Access	Locking cap for servicing the HPU reservoir
Desiccant Filter	Access to the reservoir air filter/desiccant filter
Access Door	Access for internal maintenance
Locking Swivel Caster	Locking/unlocking, foot actuated and released locking front caster
Stack Light (<i>Option SL</i>)	Displays green LED light when unit is running

5.3.2 Electrical Control Panel

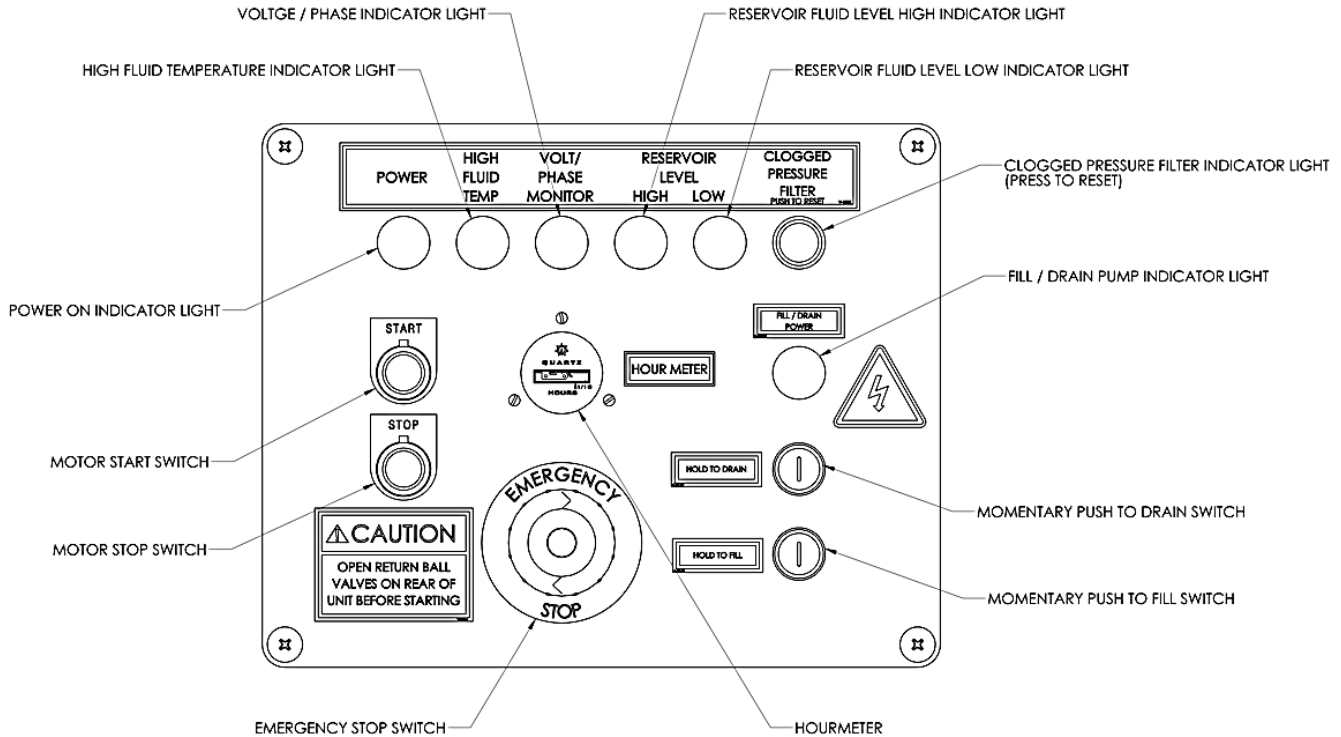

Emergency Stop	Removes power to all electrical devices, must turn to reset
Stop Switch	Turns off the electric motors driving the hydraulic pump and cooling fan
Start Switch	Turns on the electric motors driving the hydraulic pump and cooling fan
HPU Power "On" Indicator Light	Light is illuminated when the electric motors driving the hydraulic pump and cooling fan are on
High Fluid Temperature Indicator Light	Light is illuminated when the return fluid temperature reaches 170 · F (77 · C) or above. The HPU will shut down when light is illuminated. The HPU can be re-started when the fluid has cooled and the indicator light is off
High Reservoir Fluid Level Indicator Light (<i>Option L</i>)	Light is illuminated when the fluid level in the reservoir is above the normal operating range. The HPU will shut down until the fluid level is restored to a normal operating level
Low Reservoir Fluid Level Indicator Light (<i>Option L</i>)	Light is illuminated when the fluid level in the reservoir is below the normal operating range. The HPU will shut down until the fluid level is restored to a normal operating level
Voltage/Phase Monitor Indicator Light	Light is illuminated if any of the following conditions occur - Voltage imbalance between L1, L2, L3, greater than 5% - Loss of voltage from L1, L2, L3 - Change in phase orientation between L1, L2, L3. The HPU will shut down until the electrical problem is corrected
Clogged Pressure Filter Indicator Light	Light is illuminated when the pressure filter element requires changing. The HPU will not shut down when illuminated. Pressing the illuminated button will reset the light
Fill/Drain Pump Indicator Light (<i>Option</i>)	Light is illuminated when either the fill pump is on or the drain valve is open
Momentary Push to Drain Switch	When held in, fluid from the return system drains into the unit reservoir
Momentary Push to Fill Switch	When held in, an electric pump connected to the reservoir fill line supplies fluid
Hourmeter	Displays total running hours of unit

5.3.3 Hydraulic Control Panel

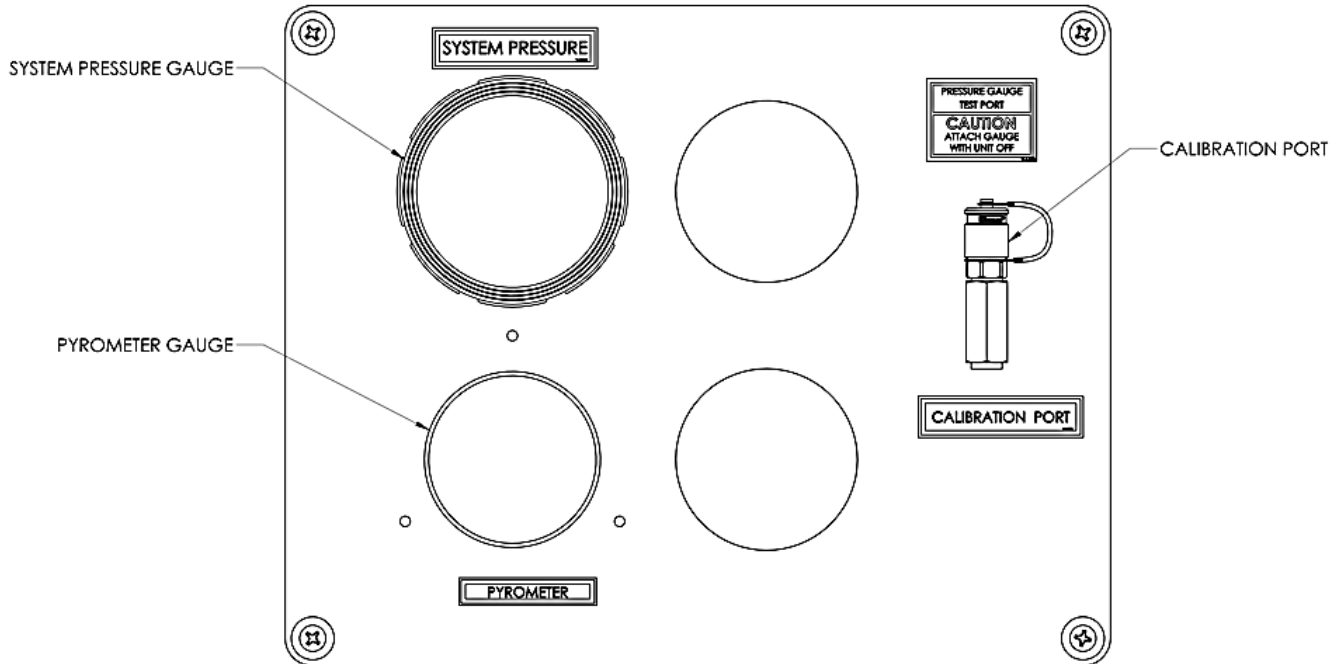

System Pressure Gauge	Displays the system pressure on an analog fluid dampened gauge
Pyrometer Gauge	Displays the fluid temperature in the return system on an analog gauge. A warning indicator preset to 160° F (71° C) warns of high operating temperature
Pressure Gauge Calibration Port	Allows for calibration of the system pressure gauge up to the operating pressure of HPU

5.3.4 Rear Panel Controls

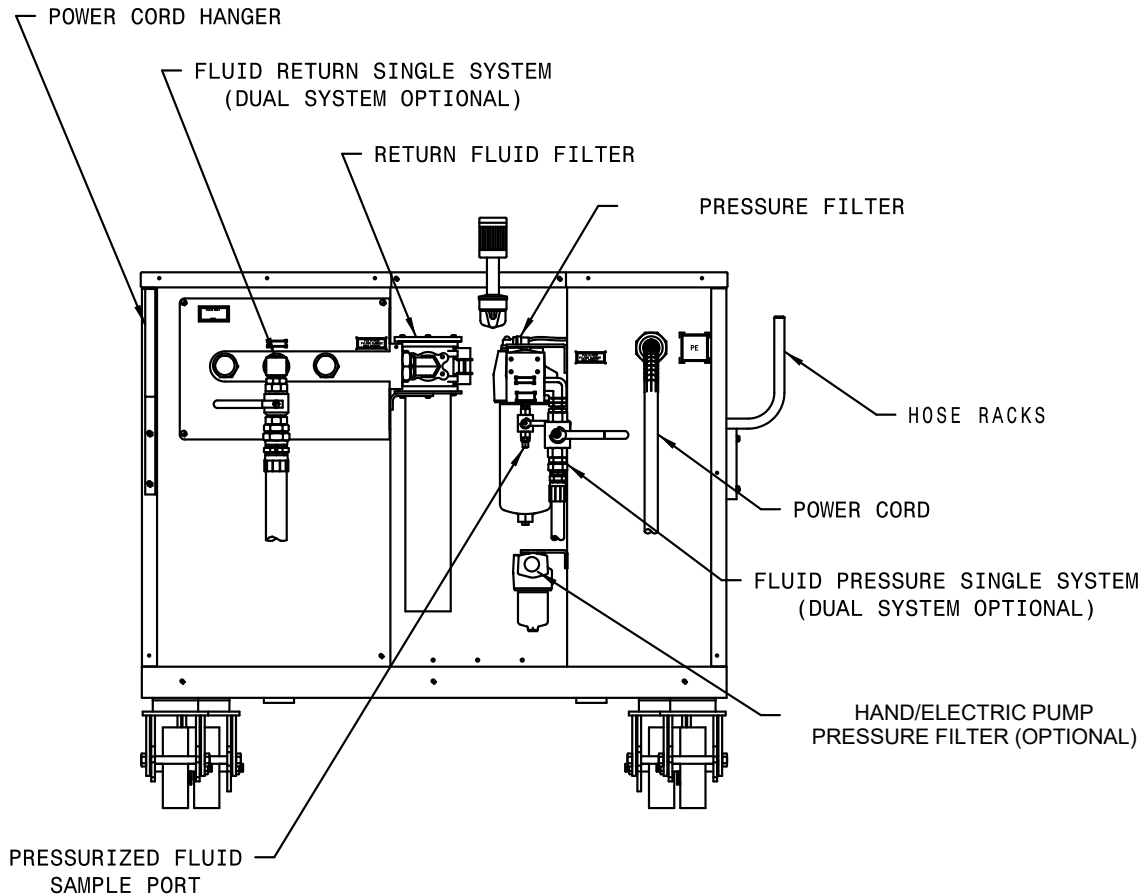

* Fluid Pressure System	The source of pressurized fluid from the HPU that flows to the aircraft pressure system through the pressure hose
* Fluid Return System	Fluid returning to the HPU from the aircraft that flows through the return hoses
Pressure Fluid Filter	Filters the pressurized fluid before it flows to the aircraft pressure system
Return Fluid Filter	Filters the fluid returning from the aircraft before it enters the HPU
Pressurized Fluid Sample Port	A sample valve is provided to obtain a fluid sample for analysis. In order to obtain a representative sample, it is suggested that ANSI/B93.19M-1972(R1993) be followed
Hand/Electrical Pump Pressure Filter <i>(Option)</i>	Filters the pressurized fluid before it flows to the aircraft system
Hose Racks	Location for storing the pressure, return and optional hand pump hoses when not in use
Power Cord Hanger	Location for storing the power cord when not in use

* **Split System (Optional) consists of two (2) each of these items.**

5.3.5 Hydraulic Pump Controls

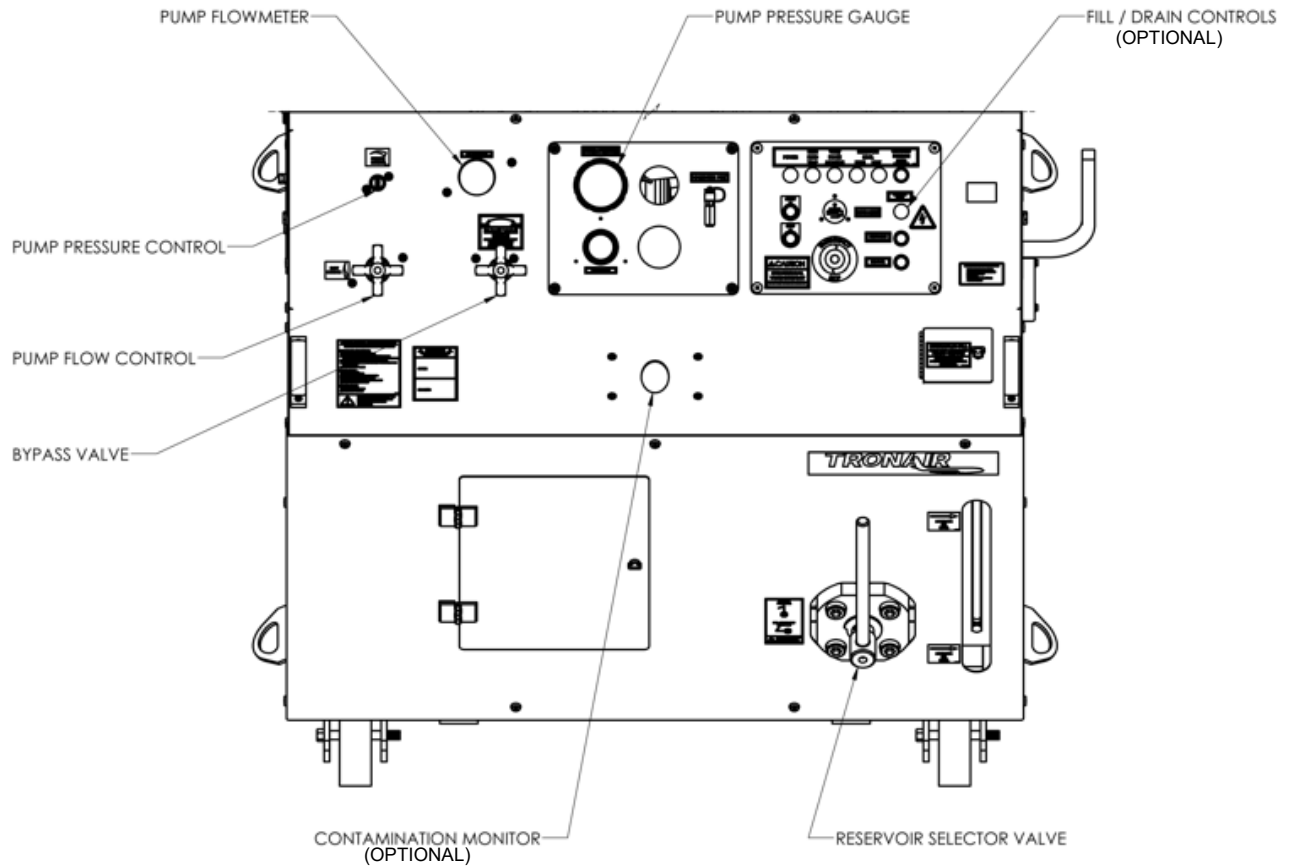

Bypass Valve	Used to upload the pump during startup and shutdown
Pump Flow Control	This control is used to set the maximum flow required from the HPU
Pump Pressure Control	The pressure control is used to set the system pressure of the HPU during operation
Pump Flowmeter	Displays pump flow in gpm & lpm
Pump Pressure Gauge	Displays system pressure of the HPU in psi & bar
Fill/Drain Controls	Used to fill or drain the aircraft reservoir
Contamination Monitor	Displays fluid cleanliness in NAS1638
Reservoir Selector Valve	Selects between HPU or Aircraft reservoir

5.3.6 Hand Pump Controls (*Option M*)
Reference 5.8 Hand Pump Operation.

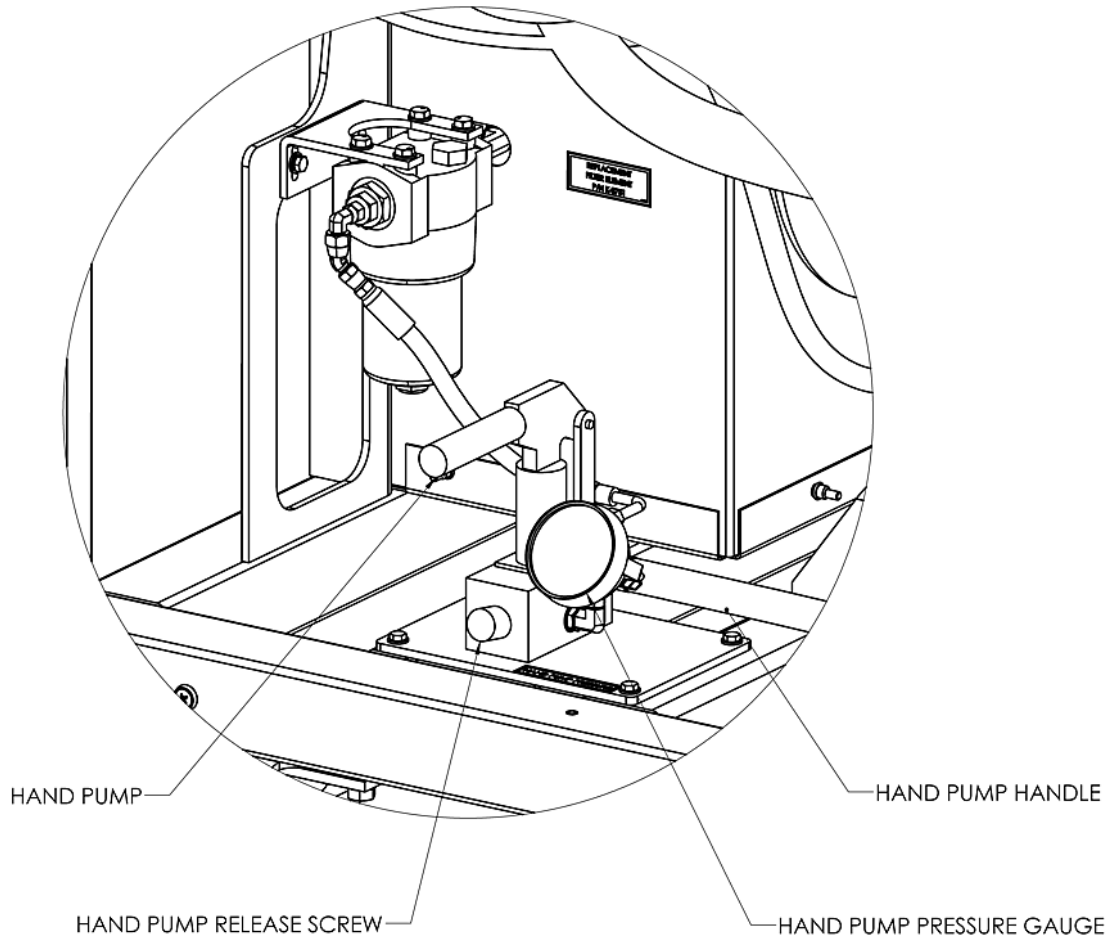

Hand Pump	Moves fluid by pumping
Hand Pump Release Screw	Accessed through the panel opening, this screw allows opening and closing of the hand pump hydraulic circuit using the hand pump handle
Hand Pump Pressure Gauge	Displays supplied pressure of the hand pump circuit
Hand Pump Handle	Located inside the access door is the hand pump handle used for opening and closing the hand pump relief screw and stroking the hand pump arm

5.3.7 Split System Controls (*Option C*)
Reference 5.7 Split System Operation.

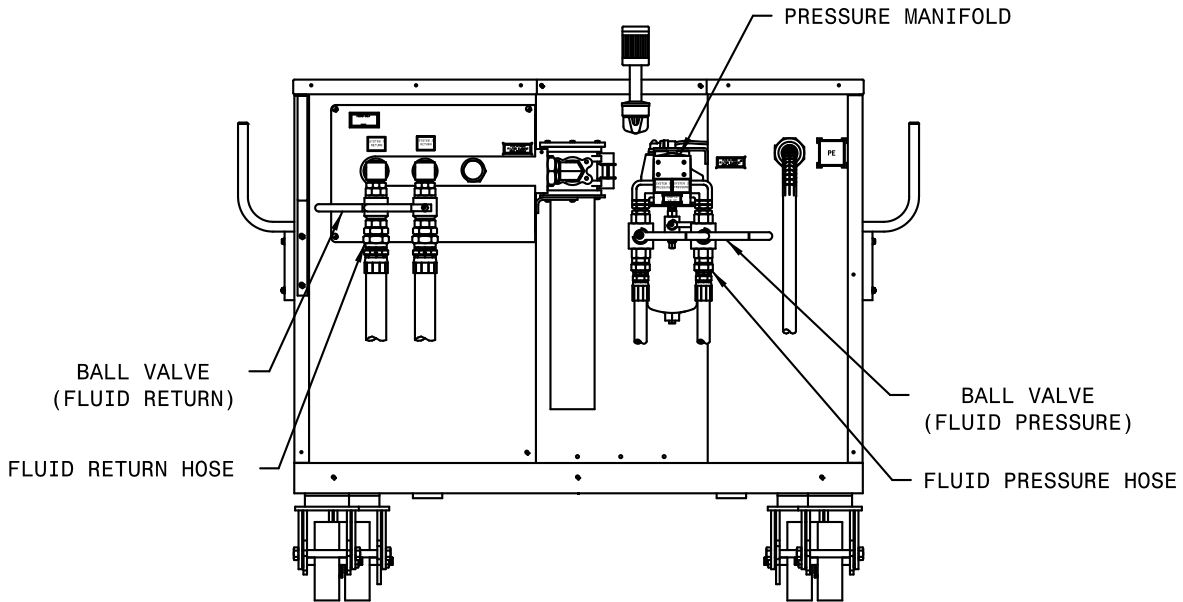

Pressure Manifold	Houses the pressure valves
Fluid Pressure Ball Valve	Used to turn on and off the flow to separate aircraft systems. Always use in either fully open or fully closed position; never use in a partially open position
Fluid Pressure Hose	Connects HPU to aircraft pressure systems
Fluid Return Hose	Connects HPU to aircraft return systems
Fluid Return Ball Valve	Used to turn on and off the flow from separate aircraft systems. Always use in either fully open or fully closed position; never use in a partially open position



WARNING!

NEVER open or close split system valves without shutting off the Hydraulic Power Unit. Damage to the aircraft system or reservoir may result if either return line valve is closed while the machine is running.

5.4 START UP PROCEDURES

5.4.1 Procedure for First Time or Different Electrical Supply ONLY

Phase Monitor: Check that the phase monitor light on the instrument panel is not illuminated. If the light is illuminated, change any two of the three input leads at the plug. Once the phase monitor light is not illuminated with power attached, check for proper motor rotation.

To check rotation (with or without Phase Monitor):

- a. Close the fluid pressure ball valve(s) at the rear of the HPU. Reference 5.3.4 Rear Panel Controls for location of ball valve.
- b. Open the bypass valve on the instrument panel fully counter-clockwise.
- c. Set the flow control on the pump to low flow (fully counter-clockwise then one turn clockwise).
- d. Place the reservoir selector valve in HPU Reservoir position.
- e. Remove the pump/motor coupling guard. Reference Pump/Motor Coupling Access figure.



Rotating Parts! Keep hands, feet, hair, and clothing away from all moving parts to prevent injury. Never operate the HPU with covers, shrouds, or guards removed.



Electrical Shock! Never touch electrical wires or components while the HPU is attached to the power source. They can be sources of electrical shock.

Do not operate HPU with cabinet panels removed.

- f. Verify that the unit has been prepared for use by connecting electrical leads and servicing the reservoir. (Reference section 3.0 Preparation Prior to First Use.)
- g. Keeping hands clear of the pump/motor coupling area, momentarily press the start button and immediately press the stop button.
- h. Observe direction of rotation of the pump/motor coupling. When the Operator is facing the front panel, the pump/motor coupling should be rotating in a clockwise direction.
- i. If the pump/motor coupling is rotating in a counter-clockwise direction, change any two of the three leads at the plug. Observe direction of rotation to verify that pump/motor is rotating in a clockwise direction.
- j. Replace the pump/motor coupling guard.

5.4.2 Initial Start Up of the HPU

- a. Unit must be prepared per section 3.0 Preparation Prior to First Use and section 5.4.1 First Time or Different Electrical Supply ONLY before starting the HPU.
- b. Operator must be familiar with this manual and be properly trained prior to starting the HPU.
- c. Connect quick disconnects to hose ends or cap the pressure and return hose ends.
- d. Close all the pressure and return ball valves on the back of unit.
- e. Place the reservoir selector valve in "HPU Reservoir" position.
- f. Place the bypass valve in the "Open" position.
- g. Press the start switch and adjust the flow control until approximately 10 gpm (38 lpm) is displayed on the flowmeter. (If no flow displays on the flowmeter after adjusting the flow control, reference Trouble Shooting 8.2 No Flow).
- h. Close the bypass valve, adjust the pressure control until 3,000 psi (206.84 bar) is displayed on the pressure gauge. (If no pressure displays on the system pressure gauge after adjusting the pressure control, reference Trouble Shooting 8.4 No Pressure or Reduced Pressure).
- i. Open the bypass valve; press the stop switch.

NOTE: Maintenance and Trouble Shooting are to be performed by a skilled and trained technician.

5.5 PRELIMINARY ADJUSTMENTS FOR OPERATION

The following are basic to the operation of the HPU and should be thoroughly understood. The pressure control has lock nuts to prevent rotation of the control shaft during operation.

5.5.1 Flow Control Adjustment

- a. Open bypass valve.
- b. Select "Hydraulic Power Unit" position with reservoir selector valve.
- c. Start HPU.
- d. Adjust flow control on pump for maximum desired flow. Observing the flowmeter, read flow in gallons (liters) per minute directly from flowmeter. Be sure the control shaft lock nut is loose during adjustment. Tighten after adjustment to maintain setting.
- e. Minimum pressure adjustment will need to be raised to achieve high flow rates.

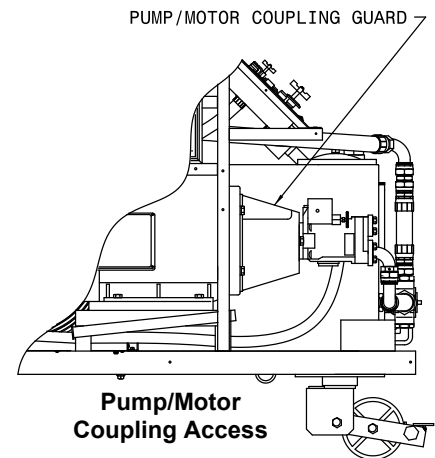

5.5.2 Pressure Control Adjustment

- a. Open bypass valve.
- b. Select "Hydraulic Power Unit" position with reservoir selector valve.
- c. Start HPU.
- d. Close bypass valve.
- e. Adjust pressure control for desired pressure; observing the system pressure gauge, read in psi (bars). Be sure the control shaft lock nut is loose during adjustment. Tighten after adjustment to maintain setting.
- f. Flow control should be set to 10 gmp (37.85 lpm) minimum to achieve full system pressure.

NOTE: Once the flow and pressure controls have been adjusted, it is not necessary to change these settings after each operation unless desired.

5.5.3 Reservoir Selector Valve Operation

Operation of the reservoir selector valve allows the operator to select either the aircraft reservoir (closed loop) or the HPU reservoir (open loop).



CAUTION!

The reservoir selector valve should only be operated when the HPU is not running. The operation of the reservoir selector valve should be done prior to starting the HPU.

- a. Aircraft Reservoir Position (Closed Loop)
In this position, the HPU is dependent on the aircraft reservoir and system for an adequate supply of fluid. Cavitation, due to an inadequate fluid supply from the aircraft, may be indicated by erratic fluctuation of the system pressure gauge or flowmeter. At times, the aircraft fluid supply will be restricted due to small return oil lines in the aircraft. If this is a problem, decrease the flow control setting until the cavitation is eliminated.
- b. HPU Reservoir Position (Open Loop)
In this position, the HPU reservoir supplies fluid to the pump and accepts return fluid from the aircraft. It is desirable to operate the HPU in this mode since it eliminates any possibility of cavitation.

Since the HPU reservoir is vented to atmosphere and the aircraft is at a higher level, it is normal for the aircraft reservoir to drain into the HPU reservoir. It is, therefore, necessary to be sure that sufficient room is available in the HPU reservoir to accommodate the additional fluid.



CAUTION!

The aircraft system reservoir must be serviced after completion of operational testing.

In the "HPU Reservoir" position, faster landing gear swings are usually possible since there is no restriction to flow at the pump inlet.

5.5.4 Bypass Valve Operation

The bypass valve is used for unloading the pump. The valve should be either in the fully open or fully closed position only. Do not operate the valve in a partially open position.

- a. Start Up Operation
The bypass valve must be opened prior to starting the HPU in order to allow the motor to start under a no load condition and not pressurize the aircraft hydraulic system.
- b. Shut Down Operation
Prior to shutdown, the bypass valve must be opened to bleed off any residual system pressure.



CAUTION!

Excessive heat, which could damage machine components, will be generated if the bypass valve is partially open or is used for regulating flow or pressure.

- Use the flow and pressure controls for regulation.
- Use the bypass valve for unloading the system only.

5.6 BLEEDING AIR FROM SYSTEM

Rapid fluctuations of the pressure gage and flow-meter are indications of cavitation or entrapped air in the hydraulic lines and/or components. Air may enter the system when:

- Operating the unit with insufficient oil in the reservoir.
- Changing a component on the aircraft.
- Changing hose connections and/or couplings.

5.6.1 To Easily Purge the Unit of Air

- a. Fill reservoir to recommended level.
- b. Open bypass valve.
- c. Place reservoir selector valve in "Hydraulic Power Unit" position.
- d. Start unit and adjust flow control to maximum position.

NOTE: If fluid is not flowing, shut off HPU and reference 8.2 No Flow in Trouble Shooting section

- e. Run unit for five (5) minutes and shut off.
- f. If additional bleeding is required, connect the pressure and return hoses together and open all pressure and return ball valves at the rear of the HPU. Start the HPU and slowly close the bypass valve (system pressure should remain under 200 psi (approximately 14 bar). Allow fluid to flow at full flow for five (5) minutes, then shut the HPU off.



WARNING!

Failure to open the return ball valves will cause hose or valve rupture. Property damage and personal injury can result.

5.7 SPLIT SYSTEM OPERATION (*Option C*)

The split system option allows control of fluid flow to aircraft with two hydraulic systems. The systems consist of two sets of hoses and valves located in the pressure and return systems. The valves are mounted on the rear of the hydraulic power unit and are of the 90° ball type. The valves are open when the operating handle is in line with the valve.

Although both systems may be operated simultaneously, usually only one system is required at any one time. If both valve sets are open simultaneously, the pump output will be divided between the two systems. Also, cross flow between aircraft reservoirs may occur if a reservoir level or pressure differential exists. Select valve positions prior to starting machine.

5.7.1 To Operate the Split System

- a. Before starting machine, open pressure and return valves of the same system.



WARNING!

Ensure pressure and return hoses of the same system are paired and used together.

- b. After completing tests on one system, shut the machine off before selecting the second system.



WARNING!

NEVER open or close split system valves without shutting off the Hydraulic Power Unit. Damage to the aircraft system or reservoir may result if either return line valve is closed while the machine is running.

5.8 HAND PUMP OPERATION

5.8.1 Hand Pump Operation (*Option M*)

The Hand Pump Option allows for filling the reservoir (low pressure) or static testing of components or system (high pressure). The hand pump circuit is separate from the main hydraulic system; a separate filter and hose are attached to the back panel of the HPU.

TO OPERATE THE HAND PUMP (*Option M*)

- a. Remove the pump handle from inside the front access door. (Reference 5.3.6 – Hand Pump Controls)
- b. Insert the end of the pump handle through the front panel opening into the hand pump relief screw.
- c. Turn the pump handle clockwise to close the relief screw.
- d. Insert the pump handle onto the hand pump arm through the front panel slot.
- e. Pump the handle using an up and down motion. Observe the hand pump system pressure on the hydraulic control panel (5.3.3 Hydraulic Control Panel). The pump is an automatic two stage pump. 500 psi (34.47 bar) can be produced with high fluid flow and 5,000 psi (344.74 bar) can be produced with low fluid flow.
- f. Turning the relief screw in a counter-clockwise direction releases hydraulic pressure in the hand pump system.



Pressurized Fluid! Before disconnecting the hand pump pressure hose, ALWAYS open the relief screw valve to relieve any residual pressure in the hydraulic system.

5.8.2 Hand Pump Operation (*Option M-7*)

The Hand Pump Option allows for filling the aircraft reservoir (low pressure). The handpump circuit is separate from the main hydraulic system, a separate filter and hose are attached to the back panel of the HPU.

TO OPERATE THE HAND PUMP

- a. Remove the pump handle from inside the access door. (Reference xxx – Hand Pump Controls)
- b. Insert the end of the pump handle into the hand pump relief screw
- c. Turn the pump handle clockwise to close the relief screw
- d. Insert the pump handle onto the hand pump arm
- e. Pump the handle using an up and down motion. Observe the hand pump system pressure gauge (Reference xxx – Hand Pump Controls). The pump is a high volume, low pressure pump designed for filling aircraft reservoirs (250 psi (17.2 bar) maximum pressure)
- f. Turning the relief screw in a counter-clockwise direction releases hydraulic pressure in the hand pump system



Pressurized Fluid! Before disconnecting the hand pump pressure hose, ALWAYS open the relief screw valve to relieve any residual pressure in the hydraulic system

5.8.3 Electric Fill Pump/Drain Operation (*Option M-E and M-F*)

This option has two features. An electric fill pump for servicing the aircraft reservoir using a motor driven pump, and a reservoir drain valve for draining the aircraft reservoir fluid into the HPU reservoir. Both features have an individual momentary button to active with an indicator light when in use.

5.9 SAMPLE VALVE

A sample valve is provided on the rear of the unit to obtain a fluid sample for analysis or inspection.

In order to obtain a representative fluid sample, it is suggested that ANSI/B93.19M-1972 (R1993) be followed.



Pressurized Fluid! Before servicing fluid, ALWAYS open the bypass valve to relieve any residual pressure in the hydraulic system.

5.10 EMERGENCY SHUT DOWN PROCEDURE

In the event an emergency shut down is necessary, press the emergency stop switch located on the electrical panel. (Reference 5.3.2 – Electrical Control Panel) Open the bypass valve to remove any system pressure.

5.11 DESCRIPTION OF ALARM SYSTEMS

Reference 5.3.2 – Electrical Control Panel.

5.11.1 High Fluid Temperature Indicator

The indicator light for high fluid temperature is an active light which will illuminate when the return fluid temperature is 160° F (71° C) or above. The HPU will shut down if the light is illuminated. The HPU can be re-started when the fluid has cooled sufficiently and the light has shut off.

If the high temperature light is illuminated reference section 8.0 Trouble Shooting.

5.11.2 Voltage/Phase Monitor Indicator

The indicator light for the voltage/phase monitor is an active light which will illuminate if there is a problem with the incoming electrical power source. The HPU will shut down if the light is illuminated.

If the voltage/phase monitor light is illuminated, reference section 8.0 Trouble Shooting.

5.11.3 High and Low Reservoir Level Indicator (*Option L*)

The indicator lights for high and low reservoir level are active lights which will illuminate when the reservoir fluid level is either above the maximum level or below the minimum level. The HPU will shut down if either of the lights are illuminated.

If the light on either of the reservoir level indicator lights, restore the fluid level in the reservoir to a normal operating range.

5.11.4 Clogged Filter Indicator Light

The indicator light for the clogged filter is a passive light which will illuminate if the pressure filter element becomes clogged or is in need of replacement. The HPU will not shut down if the light is illuminated.

If the clogged filter indicator light is illuminated, the pressure filter element requires changing. Reference section 9.13.11 Electric Filter Clogging Indicator (Option R) for maintenance procedure. Pressing the clogging filter indicator light will reset the light and the light will turn off.

NOTE: Maintenance and Trouble Shooting are to be performed by a skilled and trained technician.

5.11.5 Contamination Monitor (*Option CM*)

This feature indicates the fluid particle contamination level in real time reporting the NAS 1638 class (0 through 12)

5.12 INFREQUENT HPU USE

If the unit is not used frequently Tronair recommends operating the unit monthly. Operating regularly assures that the seals are kept lubricated, eliminates air pockets in the system, reduces moisture in the fluid and helps extend the hose life.

5.12.1 Infrequent HPU Use Start Up Procedure

1. Assure that the HPU reservoir is filled between the minimum and maximum level
2. Connect the unit to a proper electrical power source
3. If unit is equipped with a run around kit, connect the pressure and return hoses together
4. Place the reservoir selector valve in "HPU Reservoir" position
5. Open the return ball valves on the back of the unit
6. Pressure ball valves
 - a. If unit **IS** equipped with a runaround kit **ensure the hoses are connected to each other**, open the pressure ball valves on the back of the unit
 - b. If the hoses **are not connected to each other**, close the pressure ball valves on the back of the unit
7. Verify the return ball valves on the back of the unit are open
8. Fully open the bypass valve
9. Adjust the pressure control to the minimum setting (CCW)
10. Start the unit and verify the flow is above "0" on the flowmeter
 - a. If flow is present: adjust the flow control to increase flow (CW)
 - b. If no flow is immediately present: turn unit off, verify the motor rotation (see 5.4.1 Procedure for First Time or Different Electrical Supply ONLY), correct rotation if necessary
11. Set flow to ½ the maximum flow capacity of the unit. You may need to increase the pressure adjustment to achieve flow.
12. Bypass valve
 - a. If unit **IS** equipped with a runaround kit **ensure the hoses are connected to each other**, fully close the bypass valve
 - b. If the hoses **are not connected to each other**, leave the bypass valve fully open
13. Operate the unit for 15-30 minutes in this condition. Fluid temperature should reach 100°-130° F (37.8°-54.4° C)
14. At the completion of the 15-30 minute circulation run, open the bypass valve and shut off the unit
15. Remove the electric power
16. Place the selector valve in the Aircraft Reservoir position
17. Close the pressure and return ball valves on the back of the unit

6.0 PACKAGING AND STORAGE

6.1 PACKAGING REQUIREMENTS

- a. Drain hydraulic fluid until level is below the minimum fluid level indicator.
- b. Block up the unit on a pallet so the wheels are not touching the pallet or shipping container.
- c. Plug all hose ends.
- d. Strap unit to pallet or shipping container using the tie down rings located on the frame bottom.

NOTE: Use at least four (4) straps with a minimum 4,000 lb (1,814 kg) capacity each.

6.2 HANDLING

The unit is designed to be moved by hand using the handles located on the front of the unit. The unit can be lifted by means of a fork truck from the center of the machine. Lifting must be from the motor side of the unit only.

NOTE: Be sure the forks are long enough to reach the frame cross members for stability during lifting. Spread the forks to their maximum width for stability. Reference 7.0 HPU on Forklift.

6.3 PACKAGING PROTECTION

No special packaging material for cushioning or suspension is required.

6.4 LABELING OF PACKAGING

Packaging should be labeled as follows: **DO NOT DROP
THIS SIDE UP
DO NOT STACK** ↑

6.5 STORAGE COMPATIBILITY

No special considerations for short term storage (less than three months).

6.6 STORAGE ENVIRONMENT

Cover HPU with a suitable, non-abrasive tarp if storing outside. For storage periods greater than three months, drain hydraulic fluid from all hoses and the reservoir. Cover unit to protect outside surface.

If storing outside, protect unit from freezing water, sand, dirt, and direct sunlight. A cover is highly recommended.

6.7 STORAGE SPACE AND HANDLING FACILITIES

Weight (Dry).....	3,500 lbs (1,588 kg)
Width.....	63.75 in (162 cm) Add 7.5 in (19 cm) for Split System
Height.....	59 in (149.9 cm)
Depth.....	78 in (198 cm)

7.0 TRANSPORTATION

- 1 Do not stack Hydraulic Power Units.
- 2 The unit can be lifted by means of a fork truck from the motor side center of the HPU.

NOTE: Be sure the forks are long enough to reach frame cross members for stability during lifting. Spread the forks to their maximum width for stability. Reference Figure HPU on Forklift.

Weight (Dry).....	3,500 lbs (1,588 kg)
-------------------	----------------------

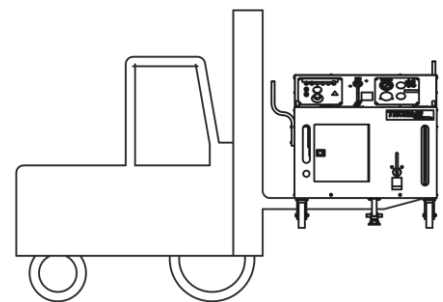

HPU on Forklift

8.0 TROUBLE SHOOTING

The following is a guide to solutions of common problems associated with the HPU. See related Appendix for Hydraulic and Electrical Schematics.

If the problem is not resolved using the trouble shooting information, call the manufacturer for Technical Assistance (See Section 1.3 Manufacturer).

NOTE: Maintenance and Trouble Shooting are to be performed by a skilled and trained Technician.

8.1 HPU WILL NOT START

Possible Cause	Solution
Supply power off	Check incoming power and restore power. Check across-the-line voltage on all three phase legs
Supply power fuses are blown/ circuit breakers tripped	Check and replace. Check across-the-line voltage on all three phase legs
Circuit breakers are tripped for the main feeder circuit	Reset circuit breakers
Supply power phase or voltage incorrect	Voltage/Phase Monitor Indicator light will be illuminated Refer to Section 3.3 Connecting Electrical Leads
Reservoir fluid level is too high or too low (<i>Electric Reservoir Level Option L only</i>)	One reservoir level indicator light (Low or High) will be illuminated. Fill the reservoir above the Minimum Fluid Level arrow to extinguish the Low Level light. Drain fluid below the Maximum Fluid Level arrow to extinguish the High Level light
High return fluid temperature	High Fluid Temperature indicator light will be illuminated. Allow the hydraulic fluid to cool until the light goes out. Refer to Section 8.5 for over-heated causes
Motor has tripped thermal overload device	Allow the motor to cool. The thermal overload device (motor starter) will reset automatically after sufficient cooling. The tripped condition is usually caused by loading the motor beyond its rated capacity; however, any condition (such as unbalanced voltage) that causes an increase in amperage can result in a tripped condition

NOTE: Using the bypass valve to meter flow or pressure will increase the motor load and may cause the thermal overload device to trip. Refer to section 5.5.4 Bypass Valve Operation for proper use of the bypass valve.

8.2 NO FLOW

Possible Cause	Solution
Motor turning in wrong direction	See Section 3.3 Connecting Electrical Leads
Flow control set too low	Increase flow setting
Fluid level in reservoir too low	Service the HPU reservoir
Air in pump inlet lines	Disconnect the HPU from the aircraft. Fill the HPU reservoir to a level above the pump inlet port. Set the reservoir selector valve to the HPU Reservoir position. Fully open the Bypass Valve. Close the Pressure and Return ball valves at the rear of the unit. Adjust the pump flow to maximum and "bump" the start and stop switches to "jog" the motor. Flow should be indicated at the Flowmeter on first or second "jog". Operate unit at high flow for 15 minutes to bleed air from internal lines. An external "runaround kit" is required to bleed air from the external hoses

NOTE: Under some conditions where a large amount of air has entered the system, the pump may not be able to draw an initial prime. If this occurs, loosen the inlet hose near the pump and allow air to escape. Re-tighten the hose when fluid appears.

Possible Cause	Solution
Motor is turning but pump is not	Check pump and motor couplings to ensure they are tight
Flow path does not exist	A flow path (such as a moving actuator or an open circuit) must exist for flow to be present. When system pressure exceeds the compensator control setting, or when the system no longer requires flow, the control de-strokes the pump while maintaining the preset pressure

8.3 REDUCED FLOW

Possible Cause	Solution
Flow control set too low	Increase flow setting.
Pressure adjustment is set too low	Slightly increase pressure setting.
Pressure compensator control is reducing pump output	When system pressure exceeds the compensator control setting, or when the system no longer requires flow, the control de-strokes the pump while maintaining the preset pressure.
Pump inlet is not receiving enough fluid (cavitation)	Follow the procedure for "Air in pump inlet lines" in Section 8.2.
Motor is "Single Phasing"	Motor is not getting power on all three phase legs. Check across-the-line voltage on all three phase legs.
Supply voltage is 50 Hz	Pumps used on 50 Hz units will flow at only 83% of the pump nameplate rating. An HPU designed to run on 50 Hz will supply flow as stated in the specifications for that unit.

8.4 NO PRESSURE or REDUCED PRESSURE

Possible Cause	Solution
Pressure adjustment is set too low	Increase pressure adjustment.
Motor is "Single Phasing"	Motor is not getting power on all three phase legs. Check across-the-line voltage on all three phase legs.
Pump inlet is not receiving enough fluid (cavitation)	Follow the procedure for "Air in pump inlet lines" in Section 8.2.
Flow path is open	Pressure is resistance to flow. The HPU will reach full pressure as flow paths (such as moving actuators and open valves) are closed.

8.5 FLUID OVERHEATS

Possible Cause	Solution
Fan is not functioning properly	Check the circuit breaker or fuses
Bypass valve or rear ball valve is being used in a partially closed position	The bypass valve and all ball valves must be used in a fully open or fully closed position. These valves are not intended for metering flow. All flow adjustments must be made using the pump flow control.

8.6 HAND PUMP (Option M or M-7) IS NOT PUMPING FLUID

Possible Cause	Solution
Release screw is open	Use the slotted end of the pump handle to close the release screw located at the base of the pump.
Ball valve is closed	Open the ball valve for the pump inlet line located at the bottom of the reservoir.
Pump piston is filled with air	If the pump is not primed after several strokes, remove the bleed screw from the top of the pump piston (See Section 9.13.9.a – Pump Diagram). Slowly stroke the pump until fluid is present at the bleed screw. Replace the bleed screw.

9.0 MAINTENANCE

If the unit is not used frequently Tronair recommends operating the unit monthly. Operating regularly assures that the seals are kept lubricated, eliminates air pockets in the system, reduces moisture in the fluid and helps extend the hose life. If the unit is not used frequently see 5.12 Infrequent Use Procedure.

9.1 GENERAL

Periodically inspect the HPU for loose fasteners, hose fittings, damaged hoses, and worn electrical cables. Make repairs as needed for safe operation.

Reference Sections 9.2 – 9.14 for Parts Lists, Descriptions and Illustrations.

Type of Maintenance/Inspection	Action	Frequency
Check fasteners, hardware, handles, and wheels	Tighten	Semi- annually
Check hydraulic fittings and flanges	Tighten	Semi- annually
Hydraulic fluid sample	Lab Test	Per Trend Results
External hydraulic hoses	Inspect/Replace	monthly
Power Cord and Electrical Plug	Inspect/Replace	monthly
Hydraulic Couplings and Plugs	Inspect/Replace	monthly
Hydraulic and Desiccant Filters	Replace	annually / 100 hrs.
Hydraulic System Operation	Verify	annually / 100 hrs.
Verify System pressure relief valve setting	Test/Reset	annually
Gauge Calibration	Certification	annually
Trailer Brake Operation	Test/Adjust	Annually
Internal hydraulic hoses	Inspect/Replace	annually

9.2 DISPOSAL OF FLUIDS

Properly dispose of hydraulic fluid by collecting it in sealed, leak-proof containers and taking it to certified recycling centers, or hazardous waste facilities.

9.3 DISMANTLING OF THE UNIT

Properly dismantling industrial equipment requires a strict, safety-first approach involving comprehensive planning, and systematic disassembly. Key steps include draining fluids to avoid contamination and using appropriate rigging gear for heavy lifting.

9.3.1 Key Procedures for Dismantling Industrial Equipment

- **Planning and Preparation:** Develop a detailed dismantling plan, including engineering assessments for weight and rigging. Ensure compliance with OSHA and environmental regulations.
- **Disconnect and Drain:** Safely drain all hydraulic fluid into appropriate containers.
- **Systematic Disassembly:** Remove external components, guards, and covers first, followed by internal parts, using cranes, forklifts, and cranes as needed.
- **Safe Handling and Cleaning:** Clean parts, inspect for damage, and store components securely on skids.

Tools and Equipment Often Required:

- **Lifting/Moving:** Cranes, forklifts, pallet jacks, and heavy-duty skids.
- **Dismantling:** Impact wrenches, socket sets, pry bars, and saws.
- **Safety:** PPE (helmets, gloves, safety glasses) and spill kits.

9.4 COMPONENT SERVICING

9.4.1 Pump Replacement

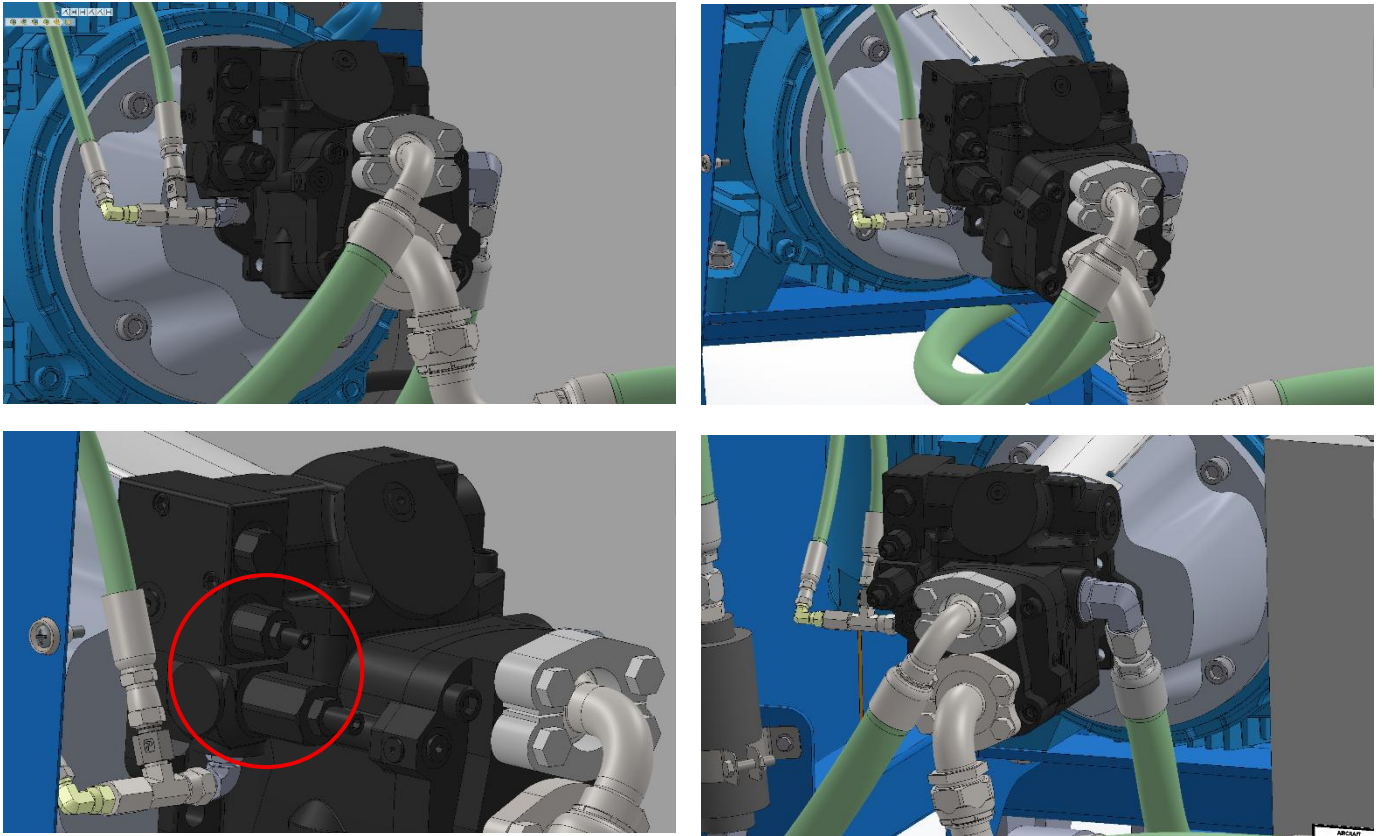

1. Remove electric power from unit
2. Close the bypass valve
3. Place selector valve in Aircraft position (vertical handle position)
4. Remove front panel from unit
5. Disconnect and cap/plug all hoses from pump
6. Remove the pump from the pump/motor adapter
7. Measure and document the location of the pump/motor coupling on the pump shaft
8. Remove the pump/motor coupling from the pump
9. Install the pump/motor coupling onto the new pump in the same location as the original pump
10. Install the new pump onto the pump/motor adapter
11. Verify that the pump/motor couplings are ~ 1/8" (3mm) of separation, adjust location of coupling if different
12. Install hoses to the new pump leaving the inlet and case drain hoses loose.
13. Fill the pump case by removing the case drain hose, turning the fitting pointing up, and pouring clean fluid until the case is full. Re-install the case drain hose and tighten
14. Change the reservoir selector valve to HPU reservoir (horizontal handle position).
15. Allow air to escape the pump inlet fitting until a solid stream of fluid escapes. Tighten the inlet fitting.
16. Torques the pressure hose flange bolts to 69±6 ft-lbs. (94±8 N-m)
17. Adjust the pump pressure relief to fully CW position (pressure relief valve is the shorter of the two valves). Tighten the locknut (see picture above)
18. Re-install the front panel on the unit
19. Close the pressure and return ball valves on the back of the unit
20. Open the bypass valve
21. Connect the unit to electrical power
22. Set the flow control to maximum setting (fully CCW)
23. Set the pressure control to fully CCW, then one turn CW
24. Bump the start button until flow is indicated on the flowmeter
25. Start the unit and adjust the flow to 10-15 gpm, circulate for 10 min.
26. Slowly close the bypass valve, unit should be able to adjust to 3000 psi. If erratic flow adjust the pressure from minimum to 3000 psi until action is steady
27. Open bypass valve
28. Install top panel
29. Shut off unit

9.4.2 PRV Setting

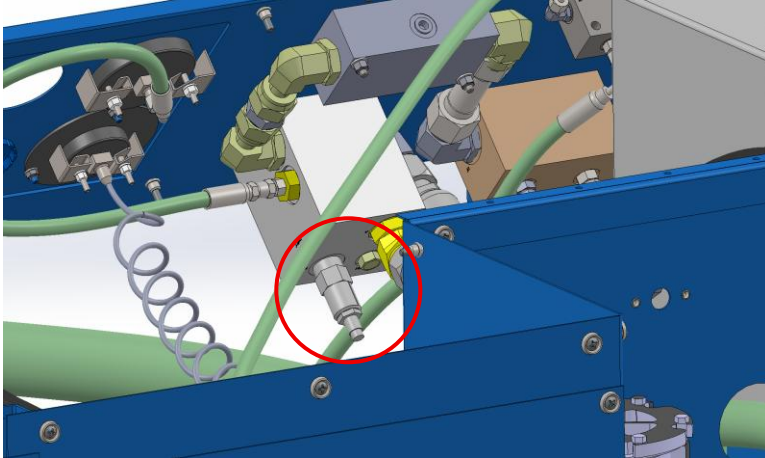

1. Remove the top panel from the unit
2. Locate the pressure relief valve (PRV) on the control manifold (see picture above)
3. Close the bypass valve on the unit
4. If replacing the (PRV), remove the old valve and install the new valve. Torque the new valve to 50-55 ft-lbs. (68-75 N-m)
5. If a newly installed (PRV), loosen the locknut on the valve and turn adjustment CCW three turns. If verifying the existing valve, loosen the locknut only
6. Close the ball valve on the back of the unit
7. Open the bypass valve on the unit
8. Start the unit and adjust the flow to 10 gpm (38 lpm)
9. Adjust the pressure control to the fully CCW position
10. Close the bypass valve
11. Increase the pressure control until flow starts indicating on the flowmeter. This indicates that the (PRV) has opened (cracking pressure)
12. Open the bypass valve to reset (close) the valve
13. Adjust the (PRV), check the cracking pressure, repeat
14. Turn the adjustment on the (PRV) until the cracking pressure is ~ 4250 psi (293 bar)
15. Repeat to verify setting
16. Should not be able to achieve more than 4350 psi (300 bar) if pressure control is increased
17. Tighten the locknut on the (PRV)
18. Open the bypass valve
19. Turn off the unit
20. Reinstall the top panel

9.4.3 Flowmeter Replacement

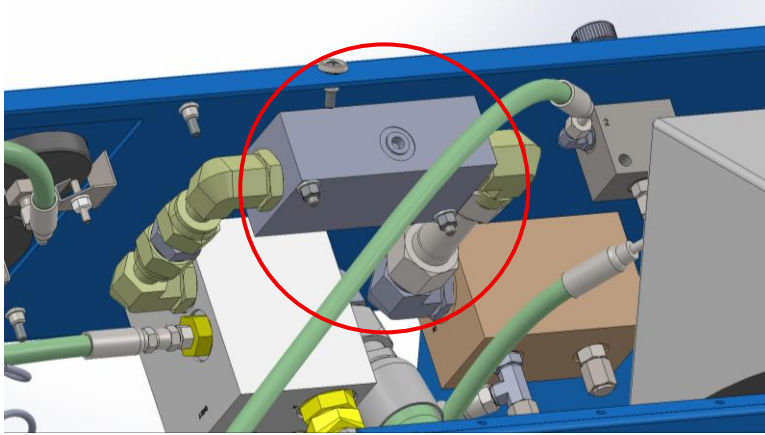

1. Remove electric power from the unit
2. Remove the top panel of the unit
3. Leave the two elbows connected to the flowmeter attached when removing
4. Loosen the fittings connected to the elbows on both inlet and outlet of the flowmeter (see picture above)
5. Remove the two bolts that hold the flowmeter to the instrument panel
6. Remove the flowmeter from the unit
7. If replacing the flowmeter, transfer the fittings onto the new flowmeter holding the same center to center dimension, and fitting to mounting bolt distances as the original assembly
8. When installing the flowmeter, loosen the two elbow adjustment nuts to allow the assembly to self-center. Adjust the straight thread depth of the elbows if necessary to maintain the proper tube to tube center, and mounting bolt location.
9. With the two elbows finger tight to the mating fittings, install the mounting bolts to the instrument panel and tighten
10. Tighten the fittings connecting to the elbows, and then tighten the locknuts on the elbows
11. Check the other fittings connected to the control manifold for proper tightness
12. Close the ball valve on the back of the unit
13. Open the bypass valve
14. Start the unit and adjust the flow to 10 gpm (38 lpm)
15. Close bypass valve and slowly increase the pressure watching for any leaks around the flowmeter while wearing proper PPE
16. Do not attempt to locate a leak while under pressure, relieve pressure and note the location and tighten fitting or re-seat the fitting if a leak is found
17. Once the unit is leak free, raise the pressure to 4000 psi (286 bar) and hold for 10 minutes to verify no leaks
18. Open bypass
19. Turn unit off
20. Reinstall the top panel

9.4.4 Pressure Gauge Replacement

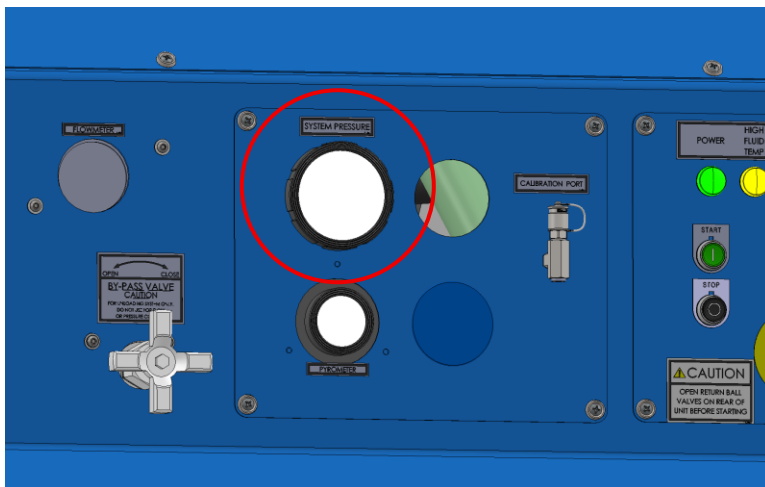
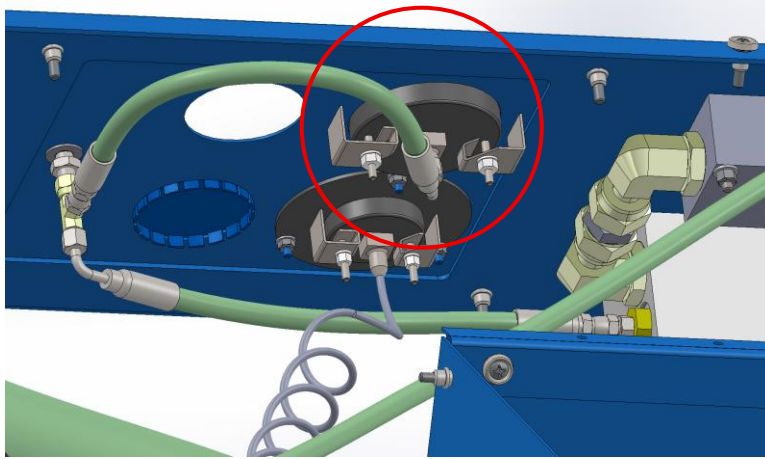

1. Remove electric power from unit
2. Remove the four mounting bolts from the hydraulic sub-panel located on the instrument panel (see picture above)
3. Disconnect the hose from the pressure gauge
4. Loosen the clamps holding the pressure gauge in place
5. Remove the pressure gauge
6. Install the new pressure gauge (or re-calibrated) in the same location on the panel
7. Tighten the mounting clamps
8. Install the hose to the gauge
9. Install the hydraulic sub-panel and mounting bolts
10. Unit is ready for operation

9.4.5 Pyrometer Replacement

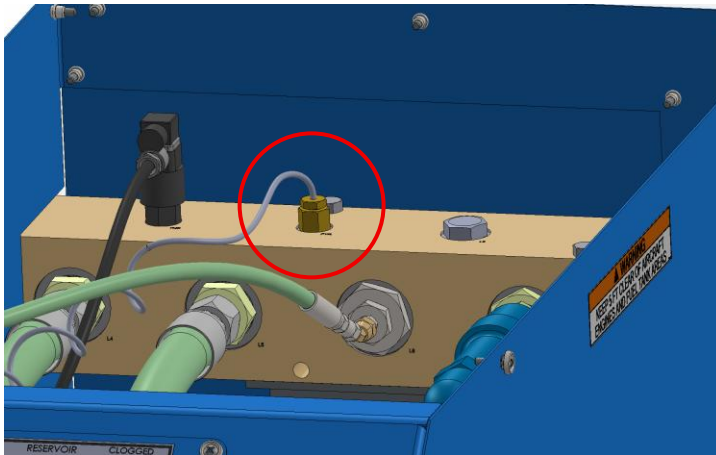
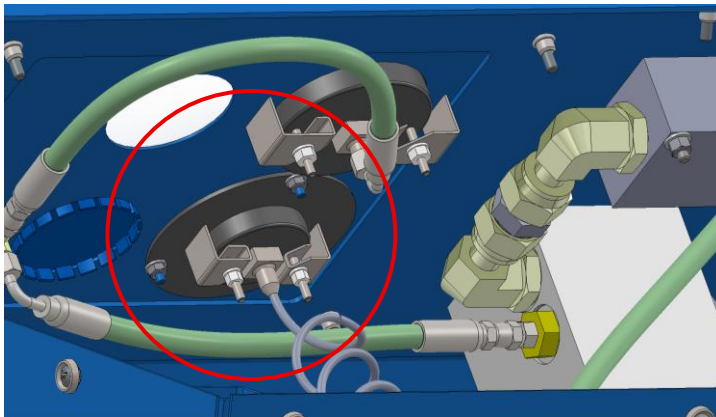
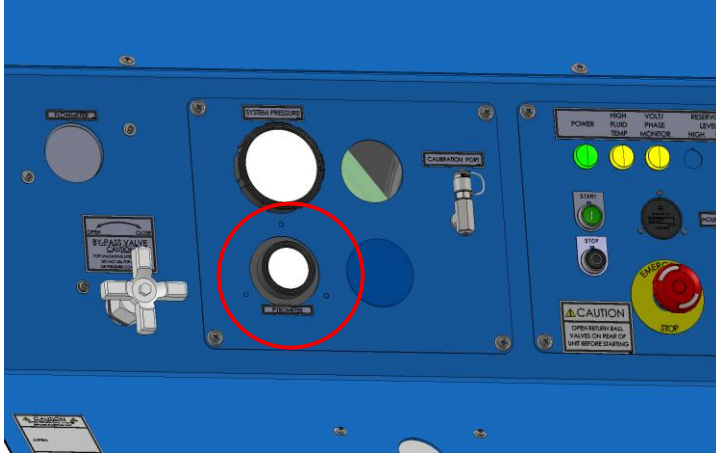

1. Remove electric power from the unit
2. Remove the top panel of the unit
3. Remove the four mounting screws from the hydraulic sub-panel
4. Remove the three nuts holding the pyrometer to the hydraulic sub-panel (see picture above)
5. Remove the pyrometer
6. On the return manifold, loosen the split fitting on the pyrometer sense cable
7. The sensing bulb can be removed without disturbing the fluid in the return manifold
8. Install the new pyrometer sense bulb in the return manifold
9. Tighten the split fitting in the return manifold
10. Install the pyrometer on the hydraulic sub-panel, tightening the three mounting nuts
11. Install the hydraulic sub-panel onto the instrument panel with the four mounting screws
12. Install the top panel
13. Unit is ready for operation

9.4.6 Noise Suppressor Servicing

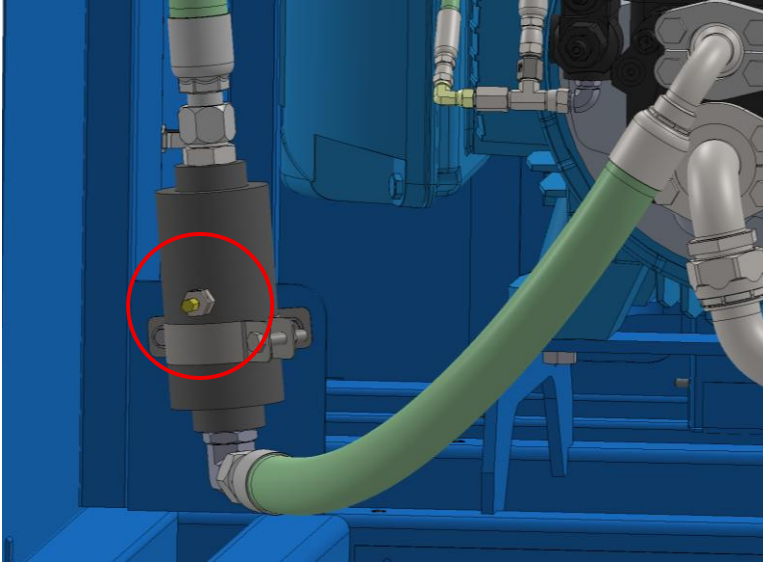

1. Remove electrical power from unit
2. Remove the front panel
3. Install a high pressure nitrogen regulator with a high pressure Schrader type valve (see picture above)
4. Loosen the swivel hex on the suppressor CCW approximately 4-1/2 turns
5. Verify the nitrogen precharge is ~ 2400 psi (165 bar)
6. Adjust the nitrogen charge on the suppressor if necessary
7. Turn the swivel hex CW approximately 4-1/2 turns
8. Torque to 50-70 in-lbs (5.6-7.9 Nm)
9. Install the front panel
10. The unit is ready to operate

9.5 ELECTRIC MOTOR

The Electric Motor is pre-greased by the manufacturer. Periodic greasing is necessary on a frequently used HPU.

Reference Appendix – Lincoln Motor Manual for details.

60 Hz Applications	
Voltage	Part Number
380	EC-1224-14
460	EC-1224-14
575	EC-1224-15

50 Hz Applications	
Voltage	Part Number
380	EC-1224-14
415	EC-1224-14
440	EC-1224-14

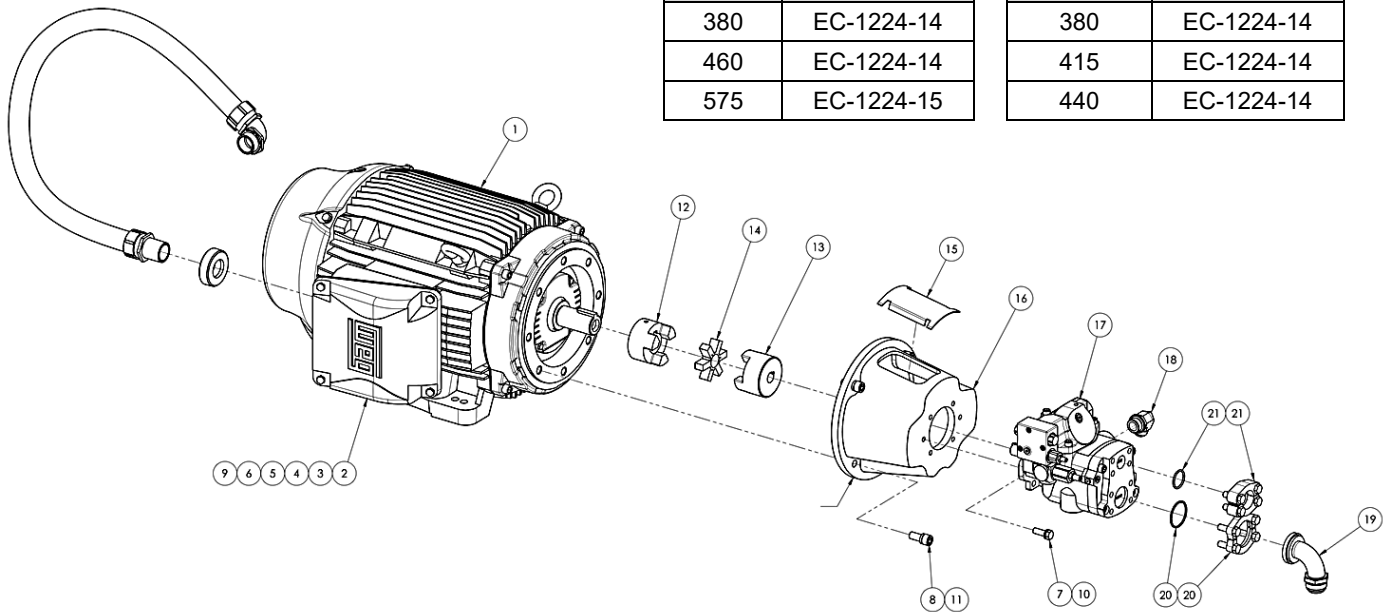

Parts List

Model Number	Fluid Type
5711	MIL-PRF-5606
5721	MIL-PRF-83282
5731	Aviation Phosphate Ester, Skydrol
5751	Aviation Phosphate Ester, HyJet

Item	5711 & 5721	5731 & 5751	Description	Qty
	Part Number	Part Number		
1	SEE TABLE	SEE TABLE	MOTOR, 3 PHASE	REF
2	EC-1034-20	EC-1034-20	TERMINAL RING - 4/0 - 1/2"	3
3	EC-1034-15	EC-1034-15	TERMINAL, RING	12
4	EC-1057-03*48.0	EC-1057-03*48.0	TUBING, HEAT SHRINK	1
5	EC-1180-66	EC-1180-66	TERMINAL, RING RED 1/2	1
6	G-1100-105505	G-1100-105505	BOLT, 1/4-28 X 5/8" LG HEX HD GR 5	6
7	G-1100-109014	G-1100-109014	BOLT, 1/2-13 X .1-1/2" HEX HD GR 5	2
8	G-1151-110214	G-1151-110214	SCREW, 5/8-11 X 1-1/2" SOCKET HD CAP	4
9	G-1202-1055	G-1202-1055	STOPNUT, 1/4-28 ELASTIC	6
10	G-1251-1090R	G-1251-1090R	LOCKWASHER, 1/2 REGULAR	2
11	G-1251-1100HC	G-1251-1100HC	LOCKWASHER, 5/8 HI-COLLAR	4
12	H-2226-03	H-2226-03	COUPLING, HALF	1
13	H-2226-14	H-2226-14	COUPLING, HALF	1
14	H-2229	H-2229	SPIDER, HYTREL	1
15	H-2568	H-2568	GUARD, COUPLING ACCESS	1
16	HC-1427-02	HC-1427-02	MOUNT, PUMP/MOTOR	1
17	HC-2909-01	HC-2915-01	PUMP, HYDRAULIC, PAINTED	1
18	N-2001-24-S-B	N-2001-24-S-E	ELBOW, STRAIGHT THREAD	1
19	N-2078-11	N-2078-11	FLANGE, 90 DEG. ELBOW	1
20	N-2545-06-S-B	N-2545-06-S-E	KIT, FLANGE	1
21	N-2664-03-S-B	N-2664-03-S-E	KIT, FLANGE	1

9.6 MOTOR DRIVEN HYDRAULIC PUMP

The hydraulic pump does not require regular maintenance. Under normal operating conditions, the pump will perform for thousands of hours of use without rebuilding. See *Appendix – Oilgear Pump Manual* for further details.

9.7 HYDRAULIC FLUID

Any time an unusual color, smell or visual indicator is noticed with the hydraulic fluid, a sample analysis should be performed to determine the condition of the fluid. (See Section 5.9 – Sample Valve Operation)

Refer to the manufacturer of the specific fluid for your unit to obtain additional information:

Model Number	Fluid Type
5711	MIL-PRF-5606
5721	MIL-PRF-83282
5731	Aviation Phosphate Ester
5751	Aviation Phosphate Ester

9.8 FILTERS

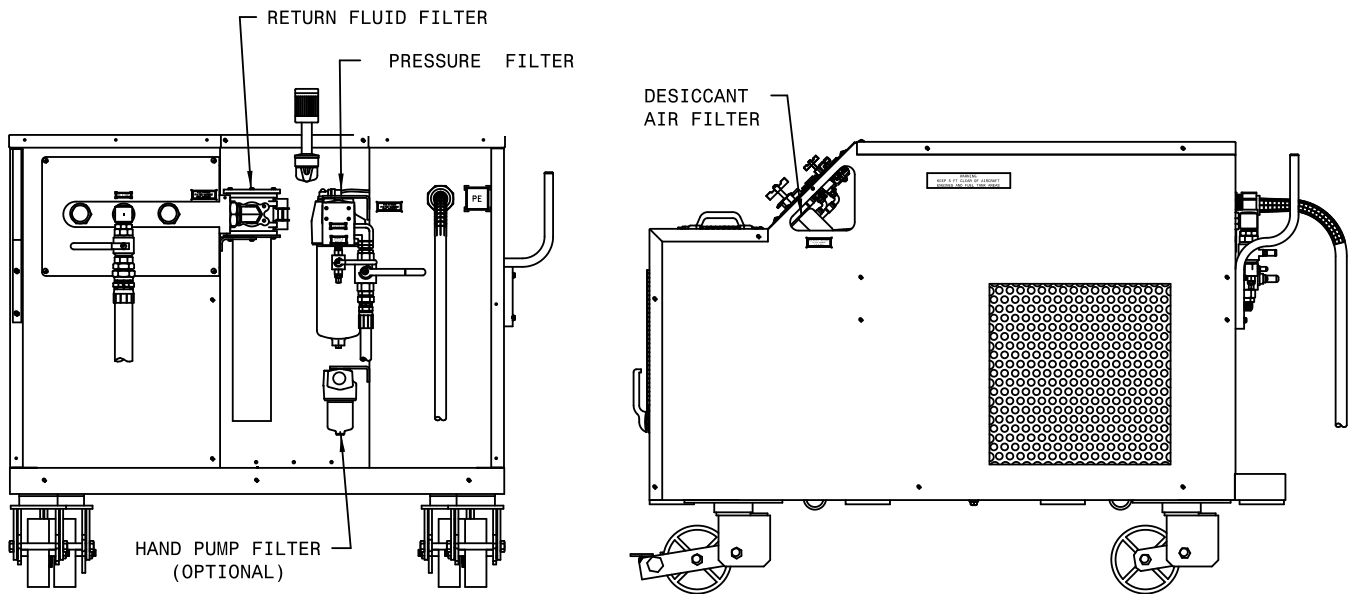

9.8.1 Pressure Filter Element

Replace the filter element any time the optional clogged filter indicator light is triggered.

Replace the filter element annually to ensure proper cleanliness of the hydraulic system. This is a minimum requirement.

Standard filter changes depend on how frequently the HPU is used and the cleanliness of the fluid, along with the environment to which the HPU is exposed. Periodic fluid analysis is recommended to properly determine the optimum frequency of filter element changes.

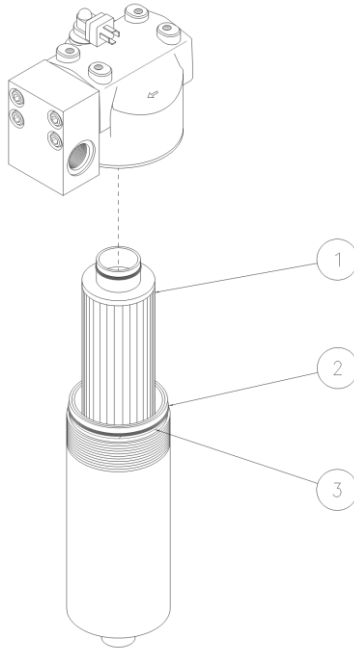

Model Number	Fluid Type
5711	MIL-PRF-5606
5721	MIL-PRF-83282
5731	Aviation Phosphate Ester, Skydrol
5751	Aviation Phosphate Ester, HyJet

	5711 & 5721	5731 & 5751		
Item	Part Number	Part Number	Description	Qty
1 - 3	K-3613	K-3614	KIT, REPLACEMENT FILTER ELEMENT (includes items 2& 3)	1
2 & 3	K-3798	K-3799	KIT, O-RING AND BACKUP RING	1

9.8.2 Return Filter Element

Replace the return filter element at the same time the pressure filter element is being replaced.

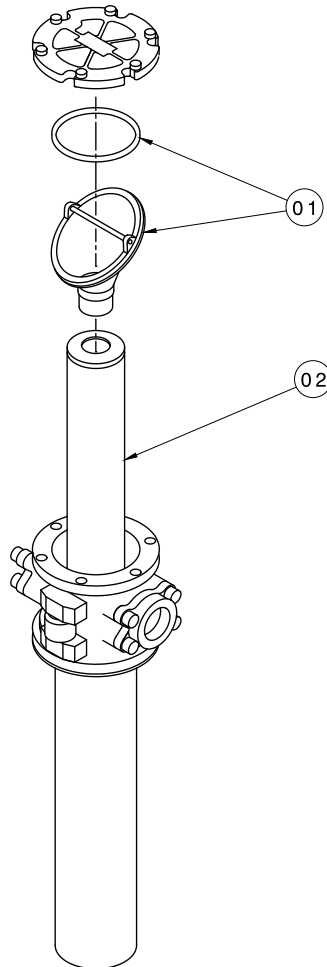

Model Number	Fluid Type
5711	MIL-PRF-5606
5721	MIL-PRF-83282
5731	Aviation Phosphate Ester, Skydrol
5751	Aviation Phosphate Ester, HyJet

	5711 & 5721	5731 & 5751		
Item	Part Number	Part Number	Description	Qty
1 & 2	K-3615	K-3616	KIT, REPLACEMENT FILTER ELEMENT (includes item 1)	1
1	HC-2000-350	HC-2006-350	O-RING	2

9.8.3 Hand Pump (Options M, M-7 and Electric Fill) Filter Element

Replacement of the hand pump filter element is dictated by frequency of use and the cleanliness of the fluid, along with the environment to which the HPU is exposed. Changing the hand pump filter element at the same time as the pressure filter element will ensure a regular maintenance schedule.

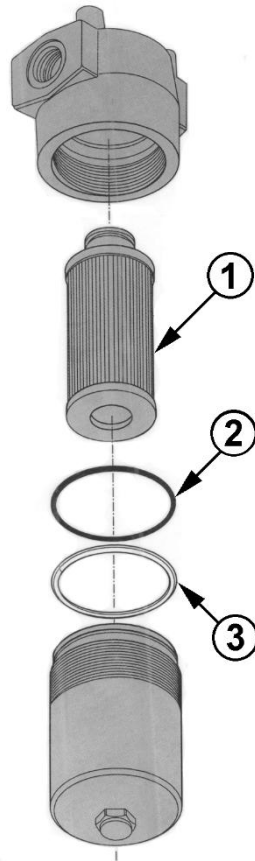

Model Number	Fluid Type
5711	MIL-PRF-5606
5721	MIL-PRF-83282
5731	Aviation Phosphate Ester, Skydrol
5751	Aviation Phosphate Ester, HyJet

	5711 & 5721	5731 & 5751		
Item	Part Number	Part Number	Description	Qty
1 - 3	K-3751	K-3752	KIT, REPLACEMENT FILTER ELEMENT (includes items 2 & 3)	1
2 & 3	K-3796	K-3797	KIT, O-RING AND BACKUP RING	1

9.8.4 Desiccant Air Filter

Replace the desiccant/air filter whenever the material inside the element is pink or reddish in color (see Element Label for details).

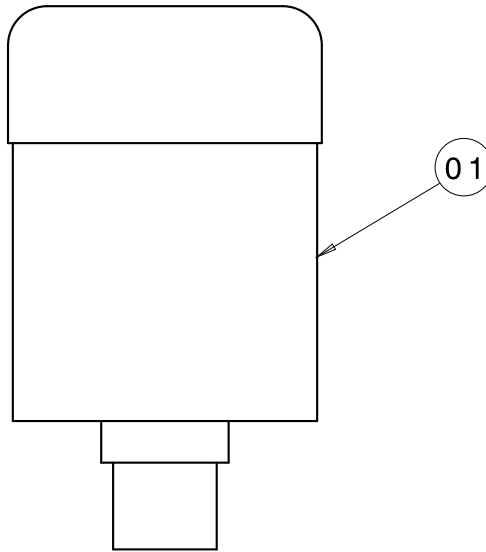

Parts List
All Fluid Types

Item	Part Number	Description	Qty
1	HC-1763	FILTER ELEMENT	1

9.8.5 Pressure Filter Assembly

The Electric Filter Clogging Indicator does not require regular general maintenance. The panel light will illuminate when the clogging indicator senses a 98 psi differential pressure across the filter element. Installing a new filter element will eliminate the clogged condition. Pushing the illuminated button will reset the indicator light.

NOTE: Higher flow rates will result in higher differential pressures. (Example: The clogging indicator may sense a 98 psi differential pressure at a flow rate of 34 gpm but not show a clogged condition when the flow rate is reduced to 10 gpm.)

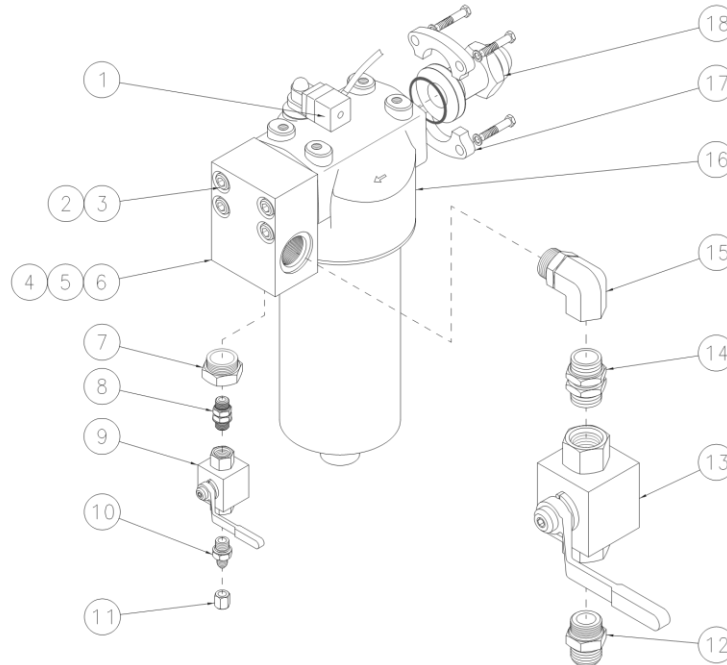

Model Number	Fluid Type
5711	MIL-PRF-5606
5721	MIL-PRF-83282
5731	Aviation Phosphate Ester, Skydrol
5751	Aviation Phosphate Ester, HyJet

Item	5711 & 5721	5731& 5751	Description	Qty
	Part Number	Part Number		
1	EC-1778	EC-1778	DIN CONNECTOR CABLE	1
2	G-1151-109224	G-1151-109224	SCREW, SOCKET HEAD CAP, 1/2-13	1
3	G-1251-1090HC	G-1251-1090HC	LOCKWASHER, HIGH COLLAR	1
4	J-3280	J-3280	FLANGE, SAE ADAPTER	1
5	HC-2000-222	HC-2006-222	O-RING, SERIES 2	1
6	N-2053-10-S-B	N-2053-10-S-E	PLUG, HEX HEAD WITH O-RING	1
7	N-2463-31-S-B	N-2463-31-S-E	FITTING, REDUCER/EXPANDER	1
8	N-2464-05-S-B	N-2464-05-S-E	UNION, #6 STRAIGHT THREAD	1
9	HC-1768-02	HC-1771-02	VALVE, BALL	1
10	N-2007-05-S-B	N-2007-05-S-E	CONNECTOR, STRAIGHT THREAD	1
11	N-2008-03-S	N-2008-03-S	CAP, #4	1
12	N-2007-24-S-B	N-2007-24-S-E	CONNECTOR, STRAIGHT THREAD	1
13	HC-1768-05	HC-1771-05	VALVE, BALL	1
14	N-2464-10-S-B	N-2464-10-S-E	UNION, #16 STRAIGHT THREAD	1
15	N-2661-06-S-B	N-2661-06-S-E	ELBOW, STRAIGHT THREAD	1
16	HC-2044-01	HC-2044-02	FILTER, PRESSURE	1
17	N-2664-03-S-B	N-2664-03-S-E	KIT, FLANGE	1
18	N-2667-05	N-2667-05	ADAPTER, FLANGE	1

9.8.6 Return Filter Assembly

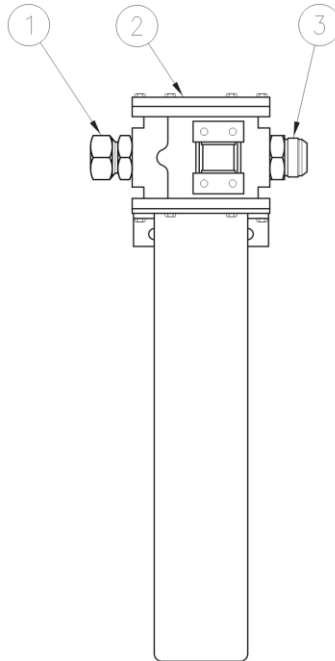

Model Number	Fluid Type
5711	MIL-PRF-5606
5721	MIL-PRF-83282
5731	Aviation Phosphate Ester, Skydrol
5751	Aviation Phosphate Ester, HyJet

Item	5711 & 5721	5731 & 5751	Description	Qty
	Part Number	Part Number		
1	N-2036-13-S-B	N-2036-13-S-E	FITTING, 37° SWIVEL	1
2	HC-2045-01	HC-2045-02	FILTER, RETURN	1
3	N-2007-31-S-B	N-2007-31-S-E	CONNECTOR, #24 STRAIGHT THREAD	1

9.9 HYDRAULIC HOSES

Hoses used on the HPU must be periodically inspected for damage, blisters, leaks, or hose end problems. Any damaged or defective hose should be replaced as soon as possible.

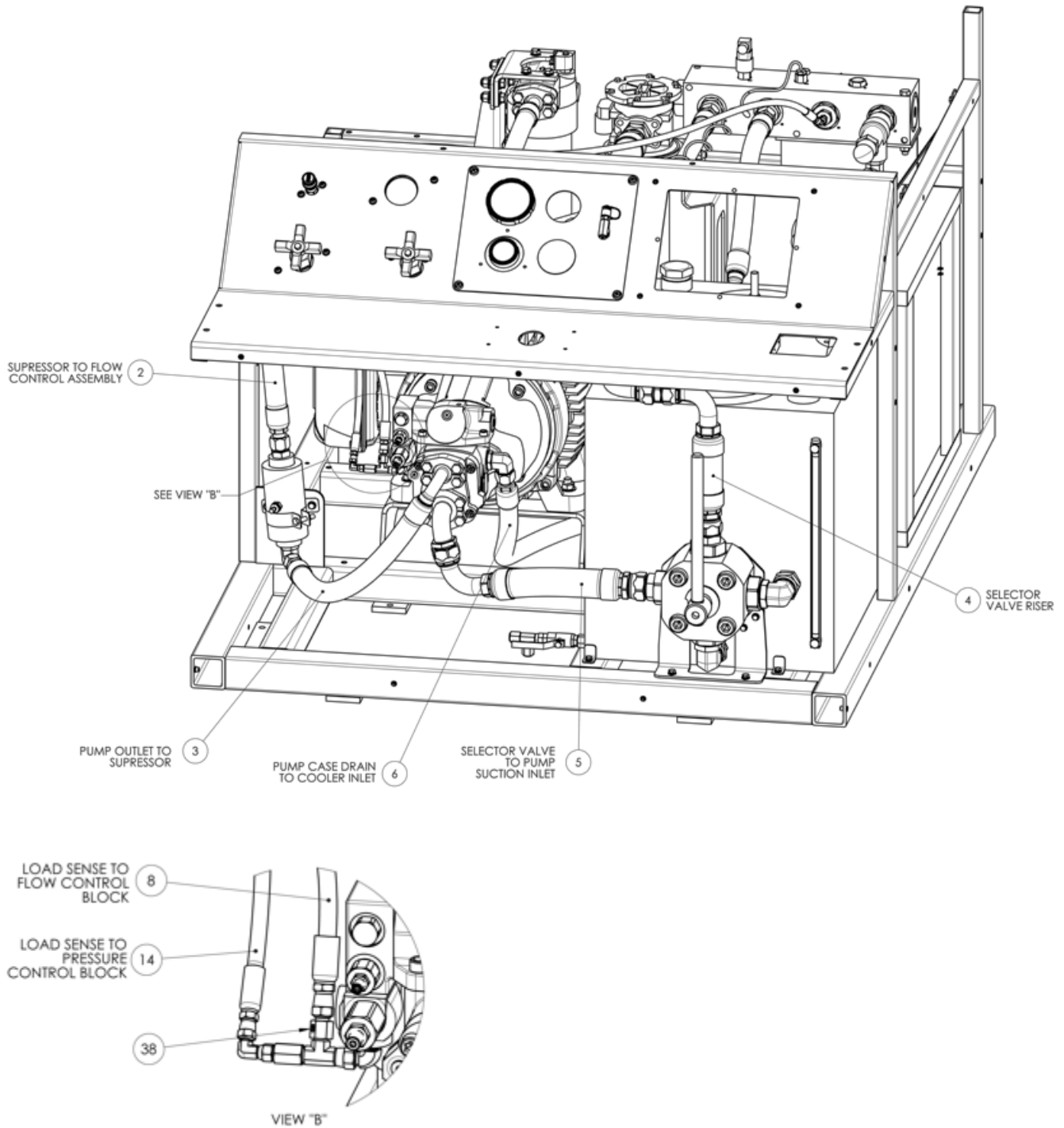

9.9 HYDRAULIC HOSES (continued)

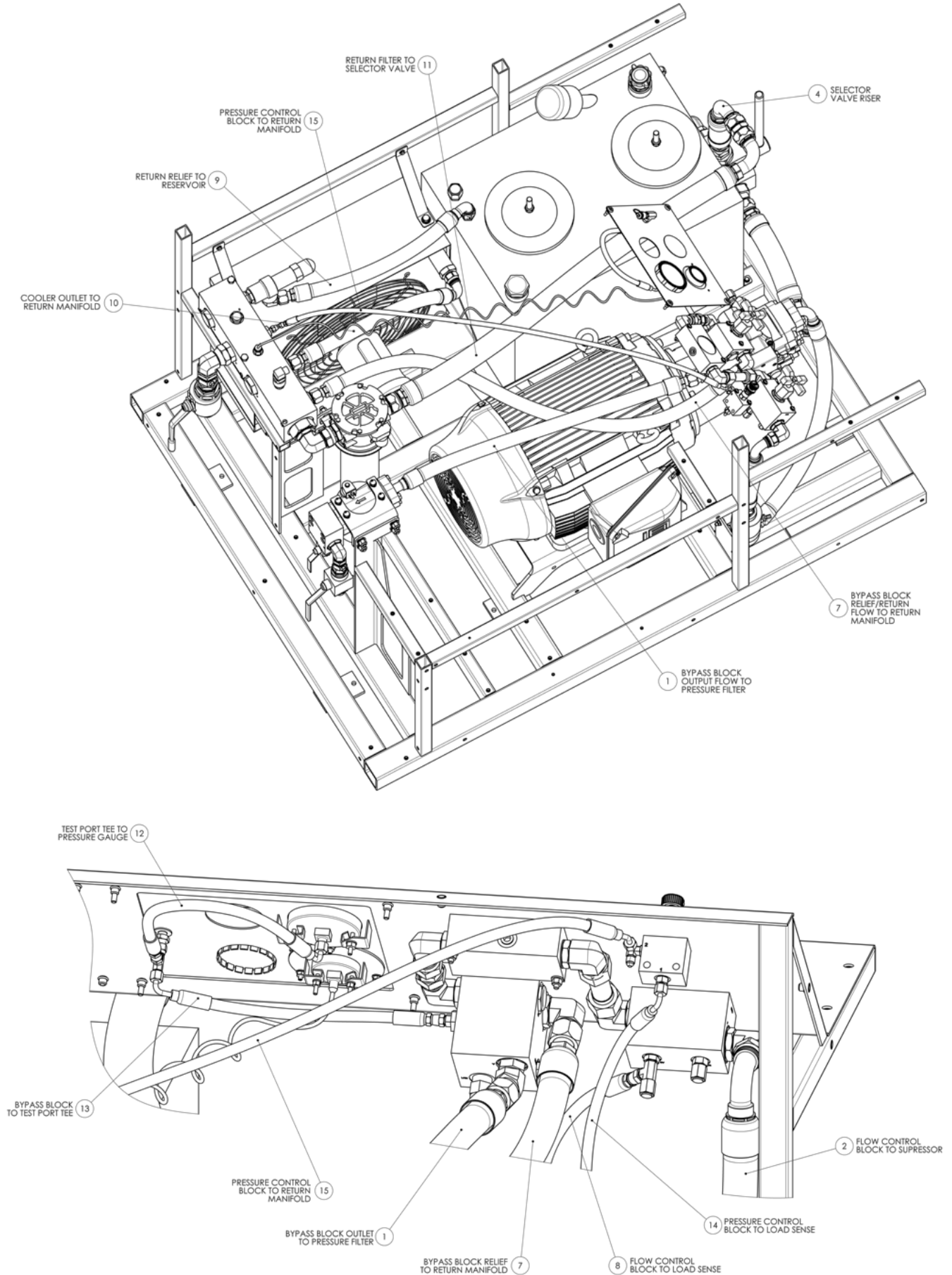

9.9 HYDRAULIC HOSES (continued)

Model Number	Fluid Type
5711	MIL-PRF-5606
5721	MIL-PRF-83282
5731	Aviation Phosphate Ester, Skydrol
5751	Aviation Phosphate Ester, HyJet

Item	5711 & 5721	5731 & 5751	From	To	Size	Length (Inch)
	Part Number	Part Number				
1	TF-1038-37-40.4	TF-1040-02-40.4	CONTROL MANIFOLD	PRESSURE FILTER	-16	40.4
2	TF-1038-31-17.8	TF-1040-17-17.8	SUPPRESSOR	FLOW CONTROL	-16	17.75
3	TF-1038-25-38.0	TF-1040-43-38.0	PUMP OUT	SUPPRESSOR	-16	38
4	TF-1039-13-12.3	TF-1040-47-12.3	SELECTOR VALVE	RISER	-24	12.25
5	TF-1039-13-17.6	TF-1040-47-17.6	SELECTOR VALVE	PUMP IN	-24	17.6
6	TF-1037-22-49.5	TF-1041-01-49.5	PUMP CASE	COOLER IN	-16	49.5
7	TF-1037-22-55.0	TF-1041-01-55.0	CONTROL MANIFOLD	RETURN MANIFOLD	-16	55
8	TF-1038-04-16.5	TF-1041-02-16.5	FLOW CONTROL	LOAD SENSE	-6	16.5
9	TF-1038-31-27.0	TF-1041-16-27.0	RETURN PRV	RESERVOIR	-16	27
10	TF-1038-31-27.0	TF-1041-16-27.0	COOLER OUT	RETURN MANIFOLD	-16	27
11	TF-1039-13-55.0	TF-1041-17-55.0	RISER	RETURN FILTER	-24	55
12	TF-1038-16-14.3	TF-1041-49-14.3	TEST PORT	PRESSURE GAUGE	-4	14.25
13	TF-1038-16-15.8	TF-1041-49-15.8	CONTROL MANIFOLD	TEST PORT	-4	15.75
14	TF-1038-16-25.5	TF-1041-49-25.5	LOAD SENSE	PRESSURE CONTROL	-4	25.5
15	TF-1038-68-56.0	TF-1041-69-56.0	PRESSURE CONTROL	RETURN MANIFOLD	-4	56

9.10 INSTRUMENT PANEL

9.10.1 Electric Panel

The Electric Panel does not require regular general maintenance.

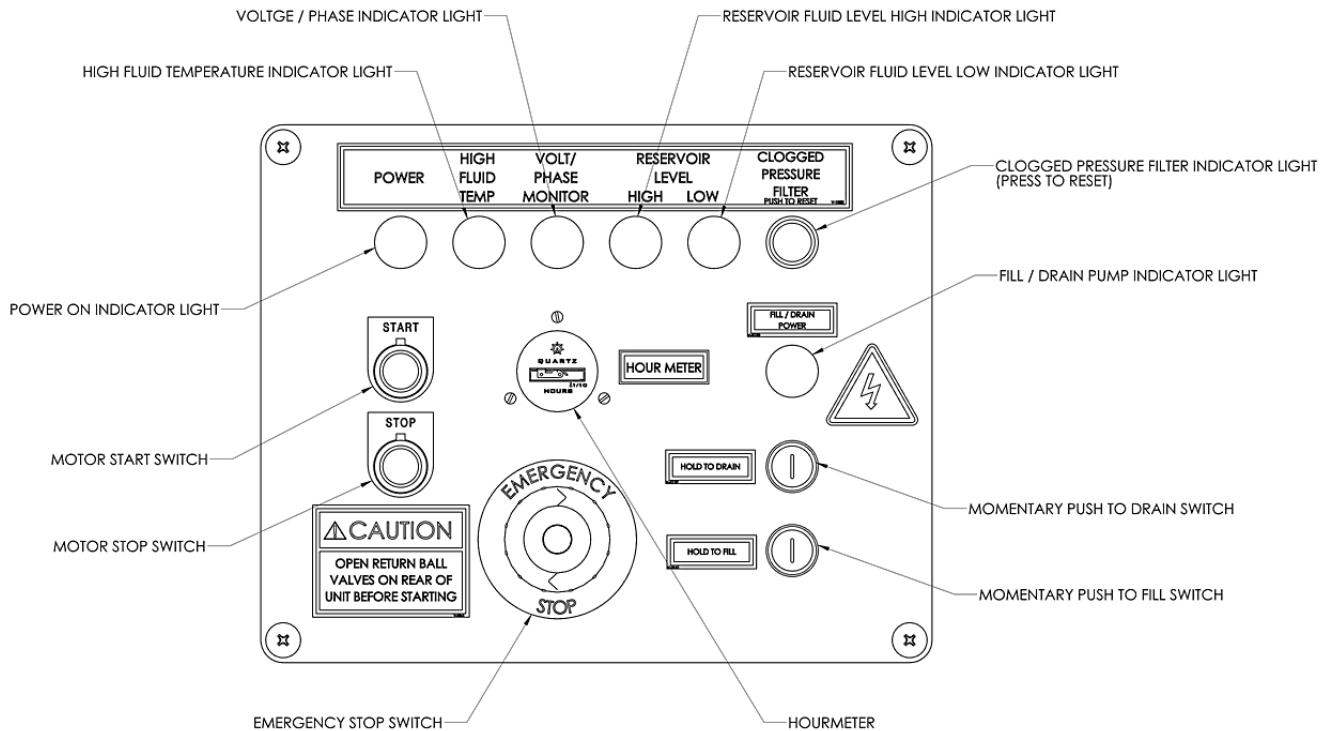

Parts List All Fluid Types

Item	Part Number	Description	Qty
1	EC-1530	PLATE, "START" LEGEND	1
2	EC-1531	PLATE, "STOP" LEGEND	1
3	EC-1799-01-SS	SEAL, OIL TIGHT HOLE	REF
4	EC-1945-01	LIGHT, DIFFUSED PILOT	1
5	EC-1945-03	LIGHT, DIFFUSED PILOT	2
6	EC-1946-MX01	CONTACT BLOCK W/LATCH	1
7	EC-1946-MX02	CONTACT BLOCK W/LATCH	1
8	EC-1946-MX10	CONTACT BLOCK W/LATCH	1
9	EC-1948	SWITCH, EMERGENCY STOP	1
10	EC-1950-02	LEGEND PLATE, E-STOP	1
11	EC-1951-MN3G	POWER MODULE WITH LATCH	1
12	EC-1951-MN3W	POWER MODULE W/ LATCH	2
13	EC-1952	PUSH BUTTON, ILLUMINATED/FLUSH	1
14	EC-1953-ME205	PUSH BUTTON, NON-ILLUMINATED	1
15	EC-1953-MF306	PUSH BUTTON, NON-ILLUMINATED	1
16	EC-3831	POWER MODULE W/CONTACT	1
17	EC-3832	HOURMETER, 10-80VDC	1
18	G-1158-106110	SCR, 1/4-20 OVAL HD CRS RC	4
19	G-1202-1000	STOPNUT, #4-40 ELASTIC	3
20	G-1477-101002	SCREW, SHEET METAL #6 X 1/4 LONG	3
21	G-1489	WASHER, COUNTERSUNK FINISH	4
22	S-2448-00	PANEL, INSTRUMENT MOUNTING	1
23	V-1665	LABEL, GROUND	1

This page left blank intentionally.

9.10.2 Hydraulic Panel

Annual calibration of instrumentation is recommended. See Section 12.0 – Calibration of Instrumentation for details of calibration.

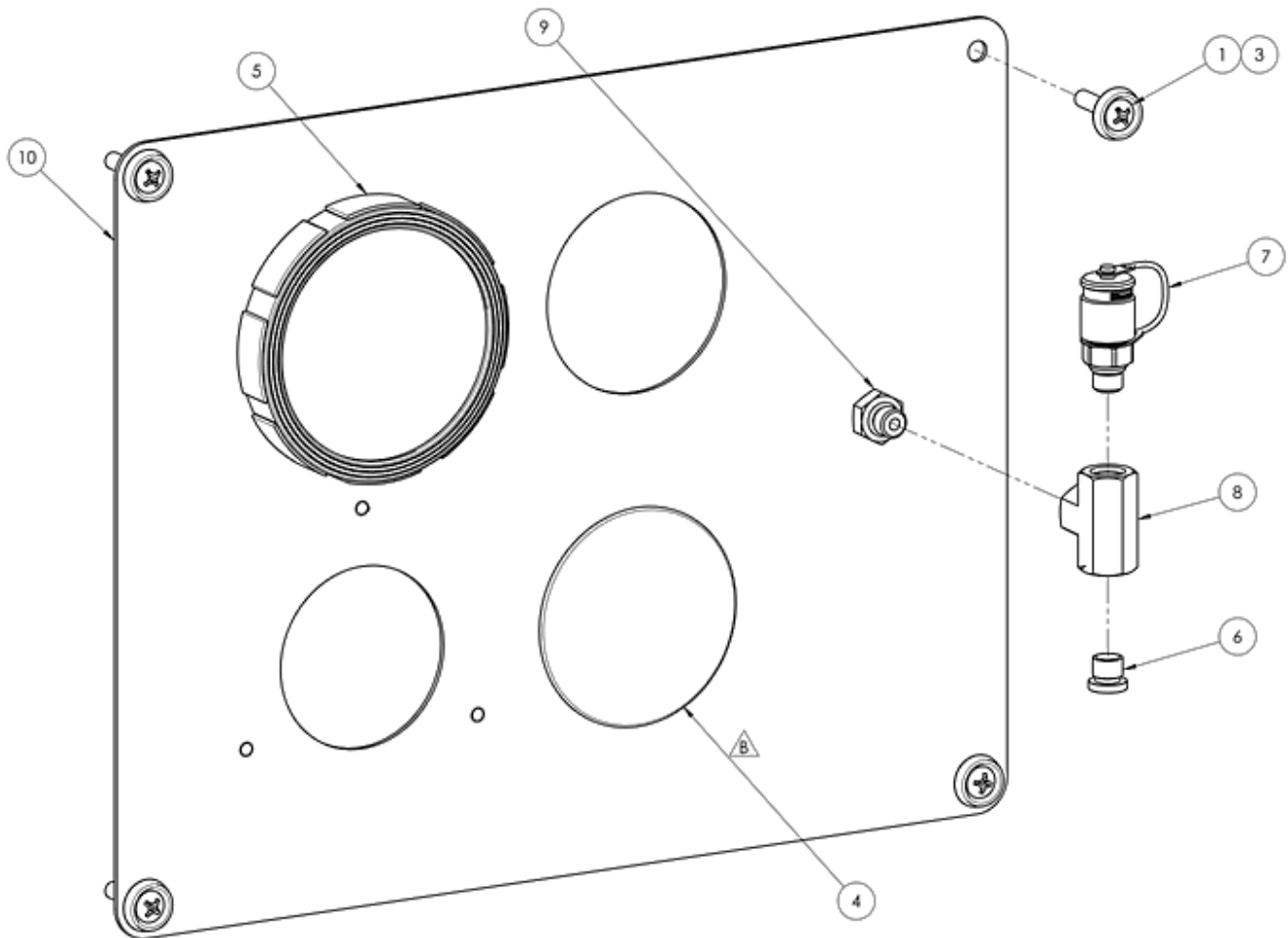
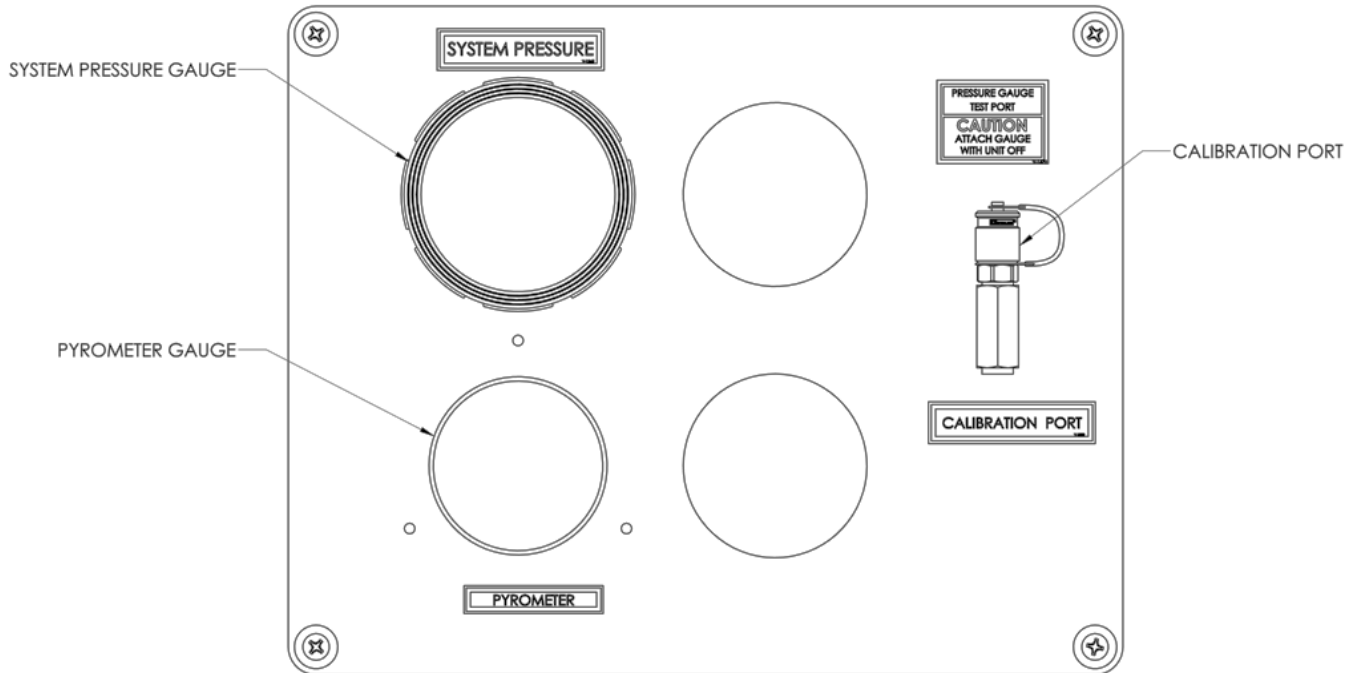

9.10.2 Hydraulic Panel (continued)

Model Number	Fluid Type
5711	MIL-PRF-5606
5721	MIL-PRF-83282
5731	Aviation Phosphate Ester, Skydrol
5751	Aviation Phosphate Ester, HyJet

Item	5711 & 5721	5731 & 5751	Description	Qty
	Part Number	Part Number		
1	G-1158-106110	G-1158-106110	SCR, 1/4-20 OVAL HD CRS RC	4
2	G-1250-1080N	G-1250-1080N	FLATWASHER, 7/16 NARROW	1
3	G-1489	G-1489	WASHER, COUNTERSUNK FINISH	4
4	H-2432-15	H-2432-15	PLUG, SHEETMETAL (PAINTED) (P)	1
5	HC-2144	HC-2144	GAUGE, PRESSURE 6000 PSI	1
6	N-2066-04-S-B	N-2066-04-S-E	PLUG, HOLLOW HEX W/ O-RING	1
7	N-2544-04	N-2548-04	TEST PORT	1
8	N-2636-01-S	N-2636-01-S	TEE, FEMALE STR THREAD	1
9	N-3121-01-S	N-3121-01-S-E	BULKHEAD, -04 JIC M X -04 SAE ORB M	1
10	S-4779-00	S-4779-00	PANEL, INSTRUMENT (P)	1

9.10.3 Flowmeter Manifold Assembly

The Pressure Manifold components do not require regular general maintenance.

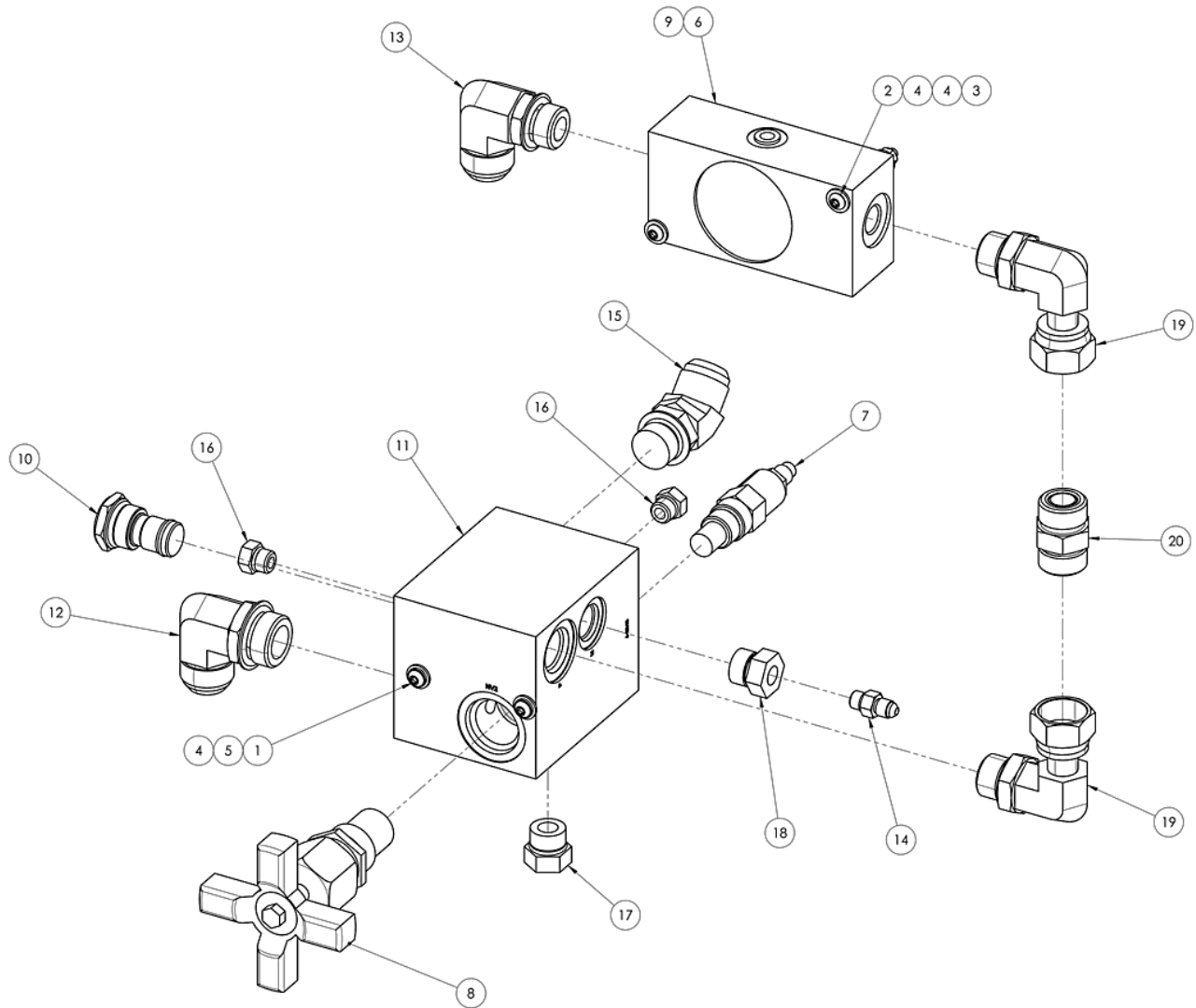

9.10.3 Flowmeter Manifold Assembly (continued)

Model Number	Fluid Type
5711	MIL-PRF-5606
5721	MIL-PRF-83282
5731	Aviation Phosphate Ester, Skydrol
5751	Aviation Phosphate Ester, HyJet

Item	5711 & 5721	5731 & 5751	Description	Qty
	Part Number	Part Number		
1	G-1154-105205	G-1154-105205	SCREW, 1/4-20 X 5/8" LG. SOC BUTT. HD CAP	2
2	G-1154-105226	G-1154-105226	SCREW, 1/4-20 X 2 3/4" LG. SOC BUTT. HD CAP	2
3	G-1202-1050	G-1202-1050	STOPNUT, 1/4-20 ELASTIC	2
4	G-1250-1050N	G-1250-1050N	FLATWASHER, 1/4 NARROW	6
5	G-1251-1050R	G-1251-1050R	LOCKWASHER, 1/4 REGULAR	2
6	HC-1404	HC-1404	FLOWMETER, 48 GPM	1
7	HC-1442	HC-1445	VALVE, PRESSURE RELIEF	1
8	HC-1254-05	HC-1927-06	VALVE, NEEDLE	1
9	----	HC-2006-014	O-RING, SERIES 2	1
10	HC-2158	HC-2159	VALVE, CHECK	1
11	J-3245	J-3245	MANIFOLD, PRESSURE	1
12	N-2001-24-S-B	N-2001-24-S-E	ELBOW, STRAIGHT THREAD	1
13	N-2001-25-S-B	N-2001-25-S-E	ELBOW, STRAIGHT THREAD	1
14	N-2007-03-S-B	N-2007-03-S-E	CONNECTOR, STR THD	1
15	N-2042-16-S-B	N-2042-16-S-E	ELBOW, 45 DEGREE STR THD	1
16	N-2053-05-S-B	N-2053-05-S-E	PLUG, HEX HD W/ O-RING	2
17	N-2053-07-S-B	N-2053-07-S-E	PLUG, HEX HD W/ O-RING	1
18	N-2463-36-S-B	N-2463-36-S-E	FITTING, REDUCER/EXPANDER	1
19	N-2634-05-S-B	N-2634-05-S-E	ELBOW, 90 DEG ORFS SWIVEL	2
20	N-2665-08-S-B	N-2665-08-S-E	UNION, ORFS	1

9.10.4 Flow Control Assembly

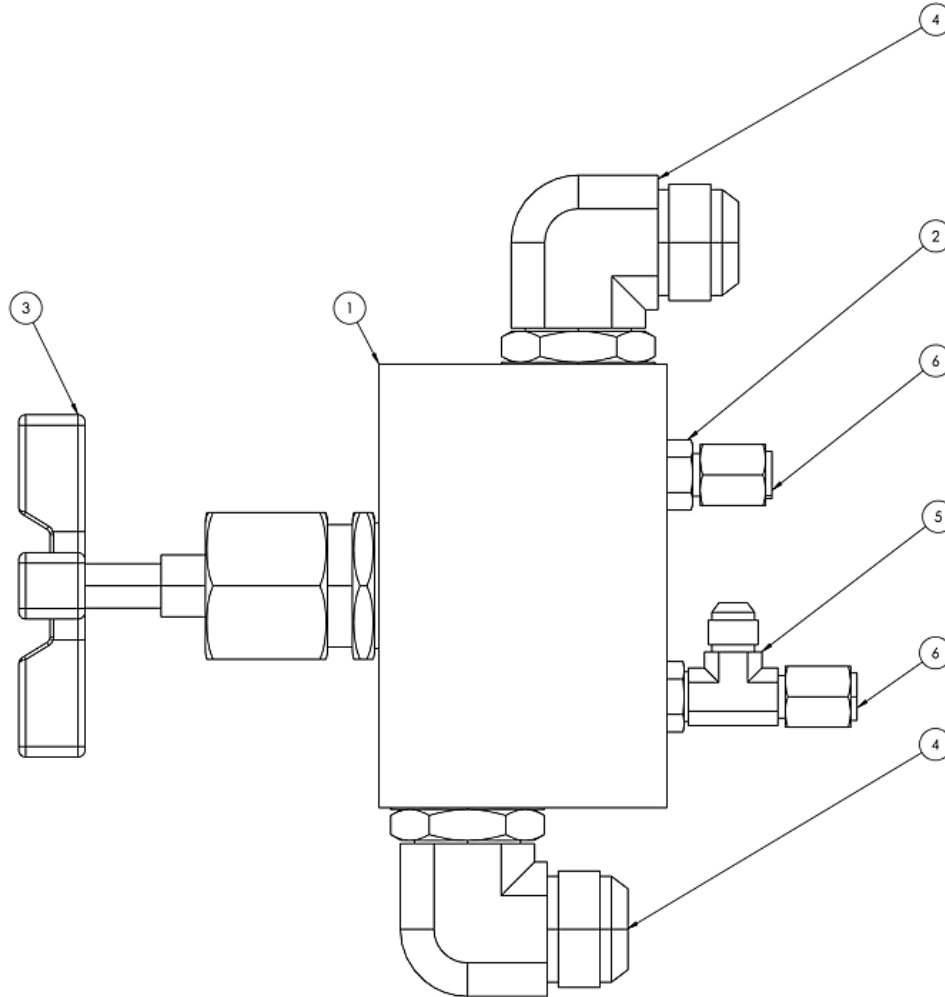

Model Number	Fluid Type
5711	MIL-PRF-5606
5721	MIL-PRF-83282
5731	Aviation Phosphate Ester, Skydrol
5751	Aviation Phosphate Ester, HyJet

	5711 & 5721	5731 & 5751		
Item	Part Number	Part Number	Description	Qty
◆ 1	J-5128	J-5128	MANIFOLD, FLOW CONTROL	1
2	N-2007-08-S-B	N-2007-08-S-E	CONNECTOR, STR THD	1
3	HC-1254-05	HC-1927-06	VALVE, NEEDLE (MB)	1
4	N-2001-24-S-B	N-2001-24-S-E	ELBOW, STRAIGHT THREAD	2
5	N-2015-08-S-B	N-2015-08-S-E	TEE, RUN STR THD	1
6	N-2008-05-S	N-2008-05-S	CAP, -6 F JIC	2

9.10.5 Pressure Control Assembly

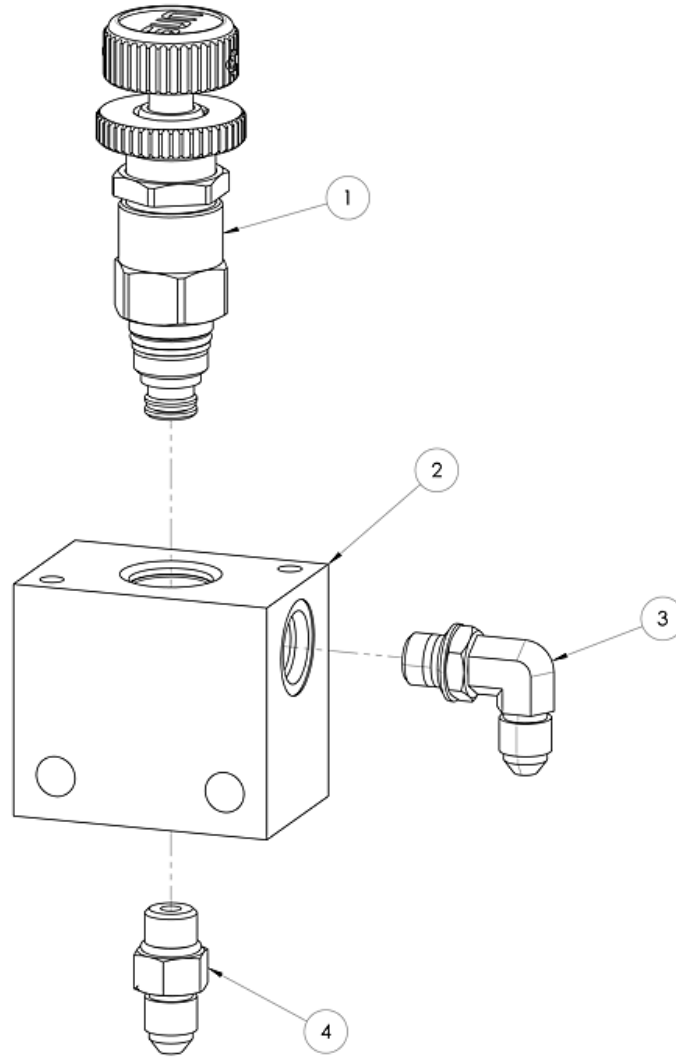

Model Number	Fluid Type
5711	MIL-PRF-5606
5721	MIL-PRF-83282
5731	Aviation Phosphate Ester, Skydrol
5751	Aviation Phosphate Ester, HyJet

Item	5711 & 5721	5731 & 5751	Description	Qty
	Part Number	Part Number		
1	HC-2793	HC-2827	VALVE, PRESSURE CONTROL	1
2	J-6603-1	J-6603-1	MANIFOLD, PRESSURE CONTROL	1
3	N-2001-03-S-B	N-2001-03-S-E	ELBOW, STRAIGHT THREAD	1
4	N-2007-03-S-B	N-2007-03-S-E	CONNECTOR, STR THD	1

9.10.6 Replacement Valves
9.10.6.a System Pressure Relief Valve

The System Pressure Relief Valve does not require regular general maintenance. It is possible however, for a contaminant to hold the relief valve in a partially open condition. If service is required, the new or repaired relief valve must be reset to 4,000 psig.

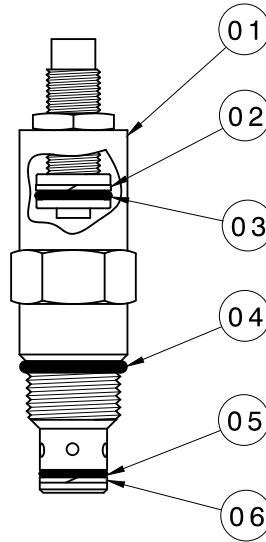

Model Number	Fluid Type
5711	MIL-PRF-5606
5721	MIL-PRF-83282
5731	Aviation Phosphate Ester, Skydrol
5751	Aviation Phosphate Ester, HyJet

	5711 & 5721	5731& 5751		
Item	Part Number	Part Number	Description	Qty
◆ 1	HC-1442	HC-1445	PRESSURE RELIEF VALVE (<i>NOT SET</i>)	1
2	HC-2020-015	HC-2020-015	BACKUP RING, (<i>TEFLON</i>)	1
3	HC-2000-015	HC-2006-015	O-RING, SERIES 2	1
4	HC-2010-910	HC-2013-910	O-RING, SERIES 3	1
5	HC-2000-014	HC-2006-014	O-RING, SERIES 2	1
6	HC-2020-014	HC-2020-014	BACKUP RING, (<i>TEFLON</i>)	1

◆ *Item 1 consists of Items 2 – 6.*

9.10.6.b Check Valve

The Check Valve does not require regular general maintenance.

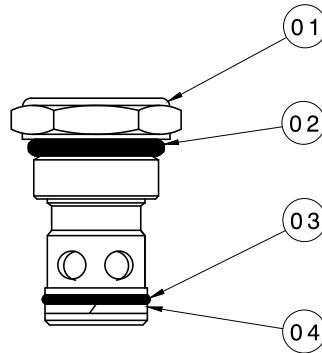

Model Number	Fluid Type
5711	MIL-PRF-5606
5721	MIL-PRF-83282
5731	Aviation Phosphate Ester, Skydrol
5751	Aviation Phosphate Ester, HyJet

Item	5711 & 5721	5731 & 5751	Description	Qty
	Part Number	Part Number		
◆ 1	HC-2158	HC-2159	CHECK VALVE	1
2	HC-2010-912	HC-2013-912	O-RING, SERIES 3	1
3	HC-2000-115	HC-2006-115	O-RING, SERIES 2	1
4	HC-2020-115	HC-2020-115	BACKUP RING	1

◆ Item 1 consists of Items 2 – 4.

9.10.6.c Bypass Valve

The Bypass Valve does not require regular general maintenance.

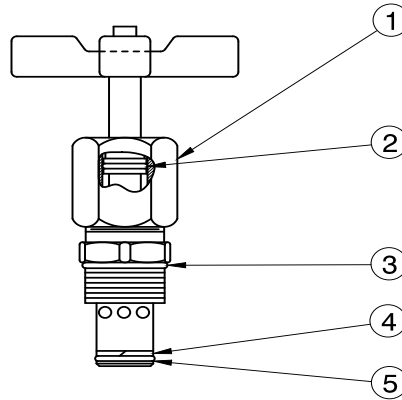

Model Number	Fluid Type
5711	MIL-PRF-5606
5721	MIL-PRF-83282
5731	Aviation Phosphate Ester, Skydrol
5751	Aviation Phosphate Ester, HyJet

Item	5711 & 5721	5731& 5751	Description	Qty
	Part Number	Part Number		
◆ 1	HC-1254-05	HC-1927-06	NEEDLE VALVE	1
2	HC-2000-112	HC-2006-112	O-RING	1
3	HC-2010-916	HC-2013-916	O-RING	1
4	HC-2020-118	HC-2020-118	BACKUP RING	1
5	HC-2000-118	HC-2000-118	O-RING	1

◆ Item 1 consists of Items 2 – 5.

9.11 RESERVOIR ASSEMBLY

Replace the desiccant air filter whenever the material inside the element is pink or reddish in color (See Element label for details). The Reservoir Assembly does not require regular general maintenance. If periodic inspections for silt are desired, be certain to thoroughly clean the dome cover and surrounding area before removing the dome cover. The Selector Valve (Item 19) is not field serviceable.

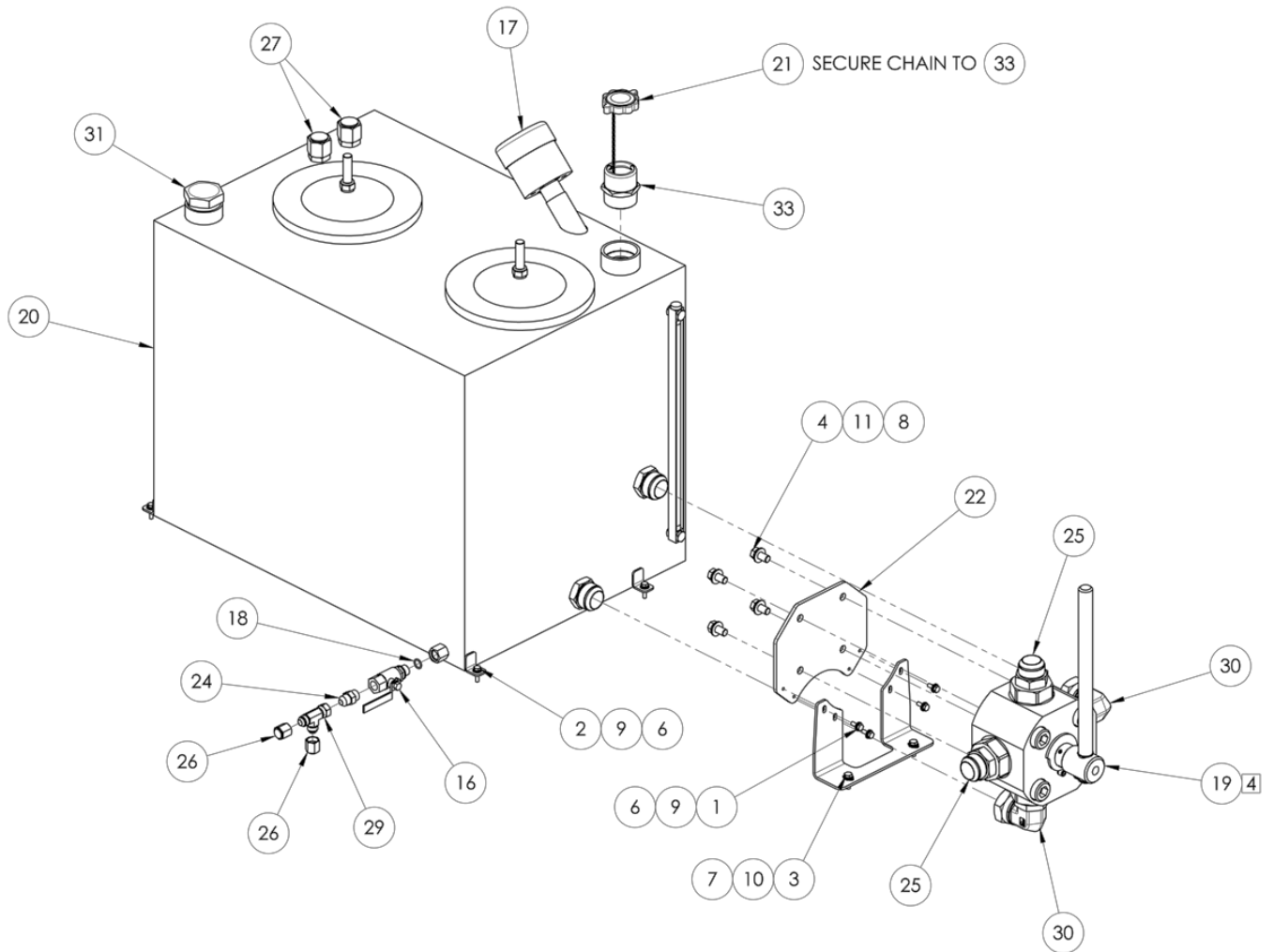

9.11 RESERVOIR ASSEMBLY (continued)

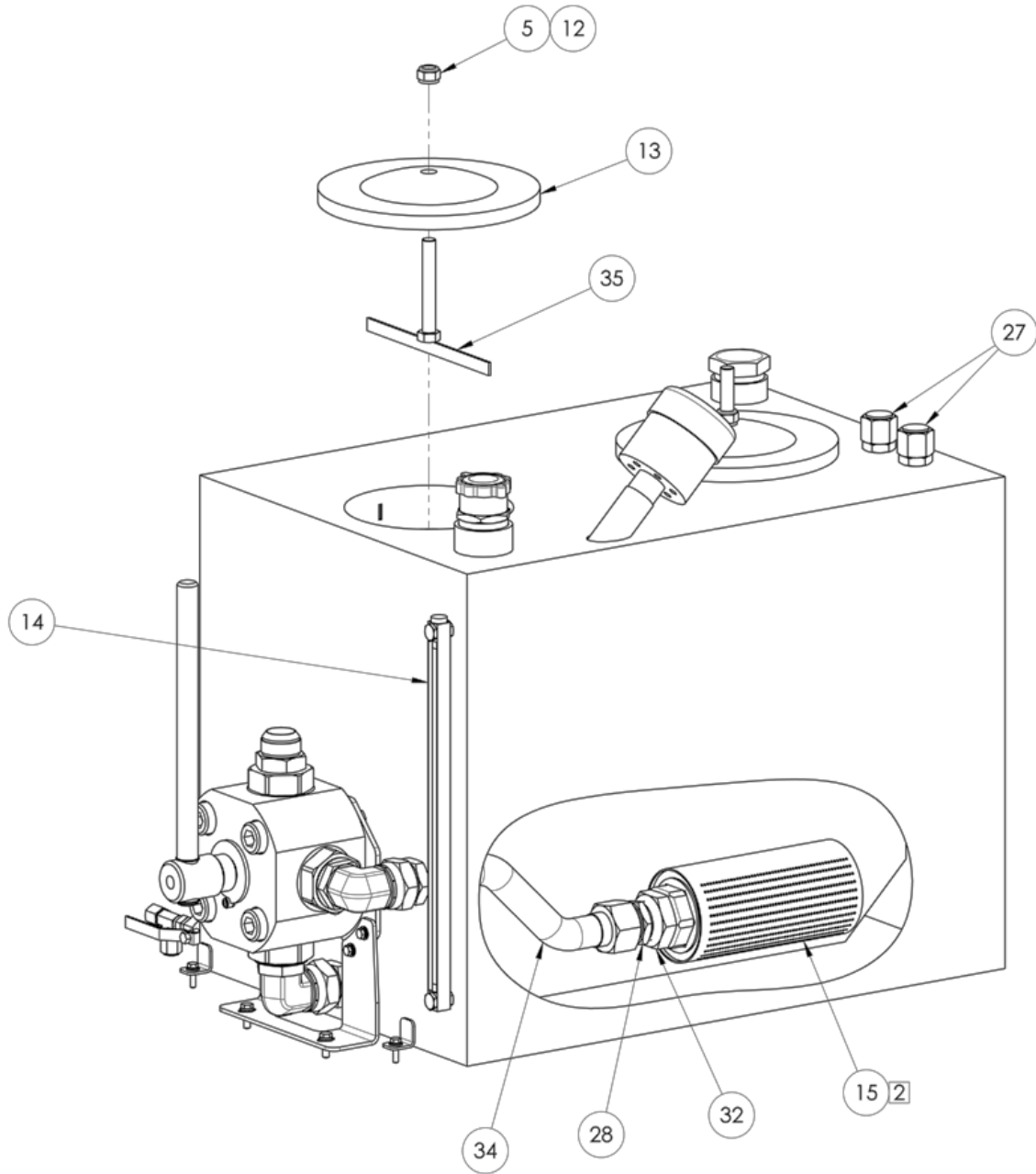

9.11 RESERVOIR ASSEMBLY (continued)

Model Number	Fluid Type
5711	MIL-PRF-5606
5721	MIL-PRF-83282
5731	Aviation Phosphate Ester, Skydrol
5751	Aviation Phosphate Ester, HyJet

Item	5711 & 5721	5731 & 5751	Description	Qty
	Part Number	Part Number		
1	G-1100-105006	G-1100-105006	BOLT, 1/4-20 X 3/4" LG HEX HD GR 5	4
2	G-1100-105010	G-1100-105010	BOLT, 1/4-20 X 1.0" LG HEX HD GR 5	4
3	G-1100-106010	G-1100-106010	BOLT, 5/16-18 X 1.0" LG. HEX HD GR 5	2
4	G-1100-109010	G-1100-109010	BOLT, 1/2-13 X 1.0" HEX HD GR 5	4
5	G-1202-1100	G-1202-1100	STOPNUT, 5/8-11 ELASTIC	2
6	G-1250-1050N	G-1250-1050N	FLATWASHER, 1/4 NARROW	8
7	G-1250-1060N	G-1250-1060N	FLATWASHER, 5/16 NARROW	2
8	G-1250-1090N	G-1250-1090N	FLATWASHER, 1/2 NARROW	4
9	G-1251-1050R	G-1251-1050R	LOCKWASHER, 1/4 REGULAR	8
10	G-1251-1060R	G-1251-1060R	LOCKWASHER, 5/16 REGULAR	2
11	G-1251-1090R	G-1251-1090R	LOCKWASHER, 1/2 REGULAR	4
12	H-1735-02	H-1735-02	WASHER, NYLON	2
13	H-1741	H-1741	ASSEMBLY, COVER	2
14	HC-1383-18	HC-1383-18	GAUGE, SIGHT	1
15	HC-1397-05	HC-1397-05	DIFFUSER	1
16	HC-1761	HC-1761	VALVE, BALL, #8 LOCKABLE	1
17	HC-1763	HC-1763	FILTER, DESICCANT	1
18	N/A	HC-2013-908	O-RING, SERIES 3	1
19	HC-3047-00	HC-3046-00	VALVE, SELECTOR (WP)	1
20	HC-3048	HC-3048	RESERVOIR, 70 GAL.	1
21	HC-3068-01	HC-3068-02	CAP, HYDRAULIC FILL	1
22	J-9263-00	J-9263-00	BRACKET A, SELECTOR VALVE (P)	1
23	J-9264-00	J-9264-00	BRACKET B, SELECTOR VALVE (P)	1
24	N-2007-11-S-B	N-2007-11-S-E	CONNECTOR, STR THD	1
25	N-2007-31-S-B	N-2007-31-S-E	CONNECTOR, STR THD	2
26	N-2008-06-SS	N-2008-06-SS	CAP, 1/2	2
27	N-2008-10-SS	N-2008-10-SS	CAP, 1	2
28	N-2009-28-S	N-2009-28-S	CONNECTOR, MALE (#24)	1
29	N-2016-06-SS	N-2016-06-SS	TEE, RUN SWIVEL NUT	1
30	N-2049-24-S-B	N-2049-24-S-E	ELBOW 90°, -24 F JIC X -24 M SAE ORB	2
31	N-2206-09-SS	N-2206-09-SS	PLUG, HEX HEAD, 2" M NPT, STAINLESS	1
32	N-2210-25-SS	N-2210-25-SS	REDUCER, PIPE THREAD	1
33	N-3271-ZN	N-3271-ZN	ADAPTER, FILL CAP	1
34	TR-2848	TR-2848	TUBE, DIFFUSER	1
35	Z-2199	Z-2199	WELDMENT, CLAMP	2

9.12 RETURN MANIFOLD ASSEMBLY

The Return Manifold does not require regular general maintenance.

NOTE: DO NOT attempt to adjust the Return System Pressure Relief Valve. See Section 9.9.1 Return System Pressure Relief Valve for details.

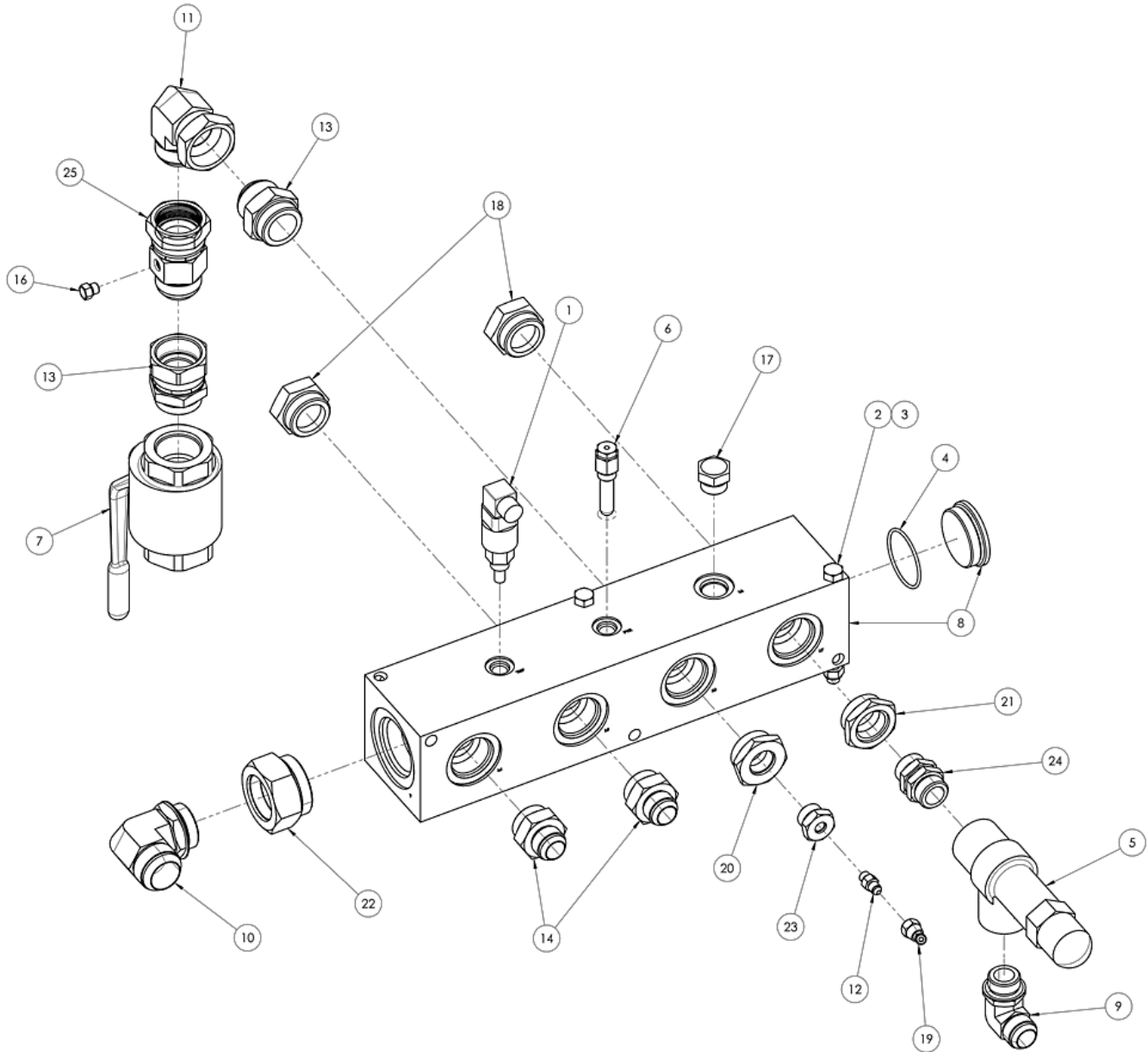

9.12 RETURN MANIFOLD ASSEMBLY (continued)

Model Number	Fluid Type
5711	MIL-PRF-5606
5721	MIL-PRF-83282
5731	Aviation Phosphate Ester, Skydrol
5751	Aviation Phosphate Ester, HyJet, Type V

Item	5711 & 5721	5731& 5751	Description	Qty
	Part Number	Part Number		
1	EC-1782-01	EC-1782-02	SWITCH, TEMPERATURE	1
2	G-1100-109554	G-1100-109554	BOLT, 1/2-20 X 5-1/4" HEX HD GR 5	2
3	G-1202-1095	G-1202-1095	STOPNUT, 1/2-20 ELASTIC	2
4	HC-2010-932	HC-2013-932	O-RING, SERIES 3	1
5	HC-2201	HC-2202	VALVE, PRE-SET PRESS RELIEF	1
6	HC-2268-01	HC-2268-02	GAUGE, PYROMETER	1
7	HC-2266-24	HC-3042-24	VALVE, BALL (6000 PSI)	1
8	HC-3070	HC-3070	MANIFOLD, RETURN ETCHED	1
9	N-2001-24-S-B	N-2001-24-S-E	ELBOW, STRAIGHT THREAD	1
10	N-2001-31-S-B	N-2001-31-S-E	ELBOW, STRAIGHT THREAD	1
11	N-2002-12-S	N-2002-12-S	ELBOW, SWIVEL NUT #24	1
12	N-2007-03-S-B	N-2007-03-S-E	CONNECTOR, STR THD	1
13	N-2007-31-S-B	N-2007-31-S-E	CONNECTOR, STR THD	1
14	N-2007-34-S-B	N-2007-34-S-E	CONNECTOR, STR THD	2
15	N-2036-13-S-B	N-2036-13-S-E	SWIVEL, 37 DEG FEMALE	1
16	N-2053-03-S-E	N-2053-03-S-E	PLUG, HEX. HD W/ O-RING	REF
17	N-2053-08-S-B	N-2053-08-S-E	PLUG, HEX HD W/ O-RING	1
18	N-2053-12-S-B	N-2053-12-S-E	PLUG, HEX HD W/O-RING	2
19	N-2081-01-S	N-2081-01-S	ELBOW, 45 DEG SWIVEL	1
20	N-2463-23-S-B	N-2463-23-S-E	FITTING, REDUCER/EXPANDER	1
21	N-2463-24-S-B	N-2463-24-S-E	FITTING, REDUCER/EXPANDER	1
22	N-2463-28-S-B	N-2463-28-S-E	FITTING, REDUCER/EXPANDER	1
23	N-2463-34-S-B	N-2463-34-S-E	FITTING, REDUCER/EXPANDER	1
24	N-2464-10-S-B	N-2464-10-S-E	UNION, #16 STRAIGHT THREAD	1
25	N-3023-08	N-3023-08	TEE, GAUGE PORT	1

9.12.1 Return System Pressure Relief Valve

The Return System Pressure Relief Valve can be purchased as a preset assembly. If the relief valve is serviced by the end user, the valve must be set to crack at 150+/-7 psig **before** being re-installed on the HPU.

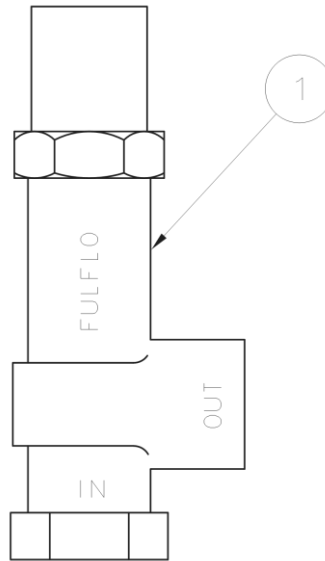

Model Number	Fluid Type
5711	MIL-PRF-5606
5721	MIL-PRF-83282
5731	Aviation Phosphate Ester, Skydrol
5751	Aviation Phosphate Ester, HyJet

	5711 & 5721	5731 & 5751		
Item	Part Number	Part Number	Description	Qty
1	HC-2201	HC-2202	VALVE, PRESSURE RELIEF (<i>PRE-SET</i>)	1
N/S	◆ HC-2000-220	◆ HC-2006-220	O-RING, SERIES 2	1

◆ *Included with Item 1*

9.13 ELECTRICAL COMPONENTS

Regularly inspect the external power cord for nicks, cuts, abrasion, and fluid damage. Replace power cord if damage is found. See Section 10.0 Provision of Spares for recommended spare fuses.

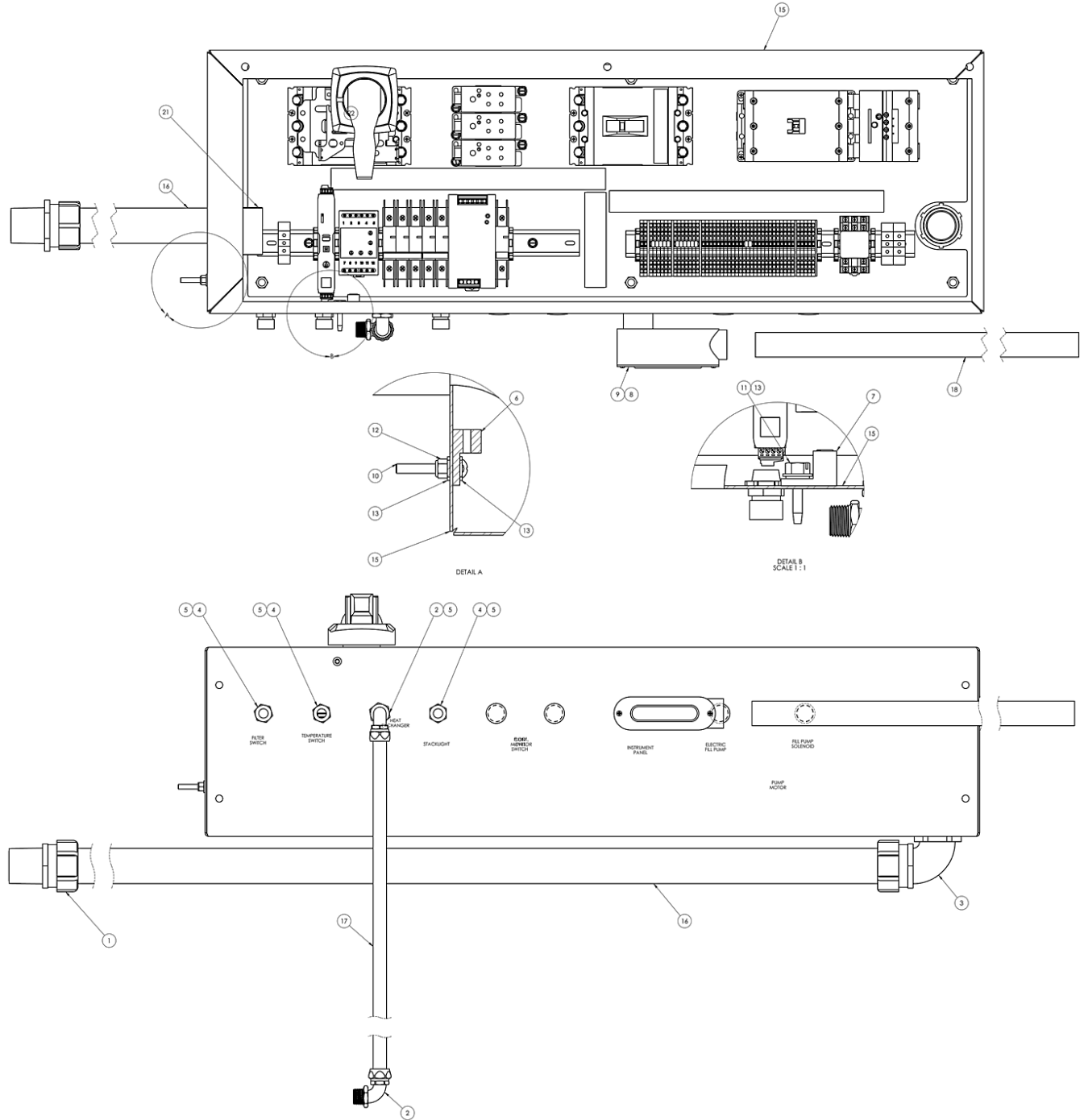

9.13 ELECTRICAL COMPONENTS (continued)

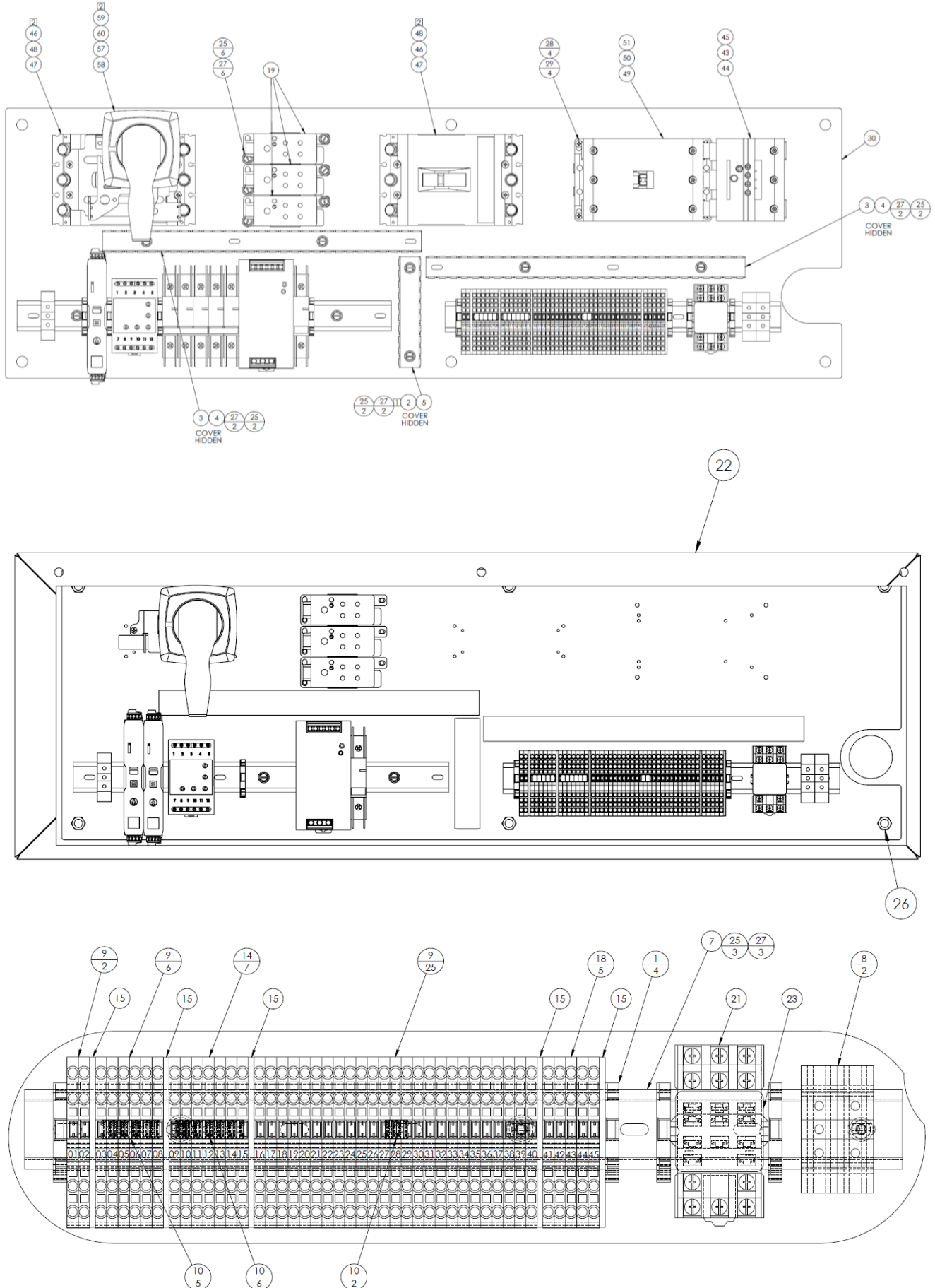

9.13 ELECTRICAL COMPONENTS (continued)
575 VOLT PTION ONLY

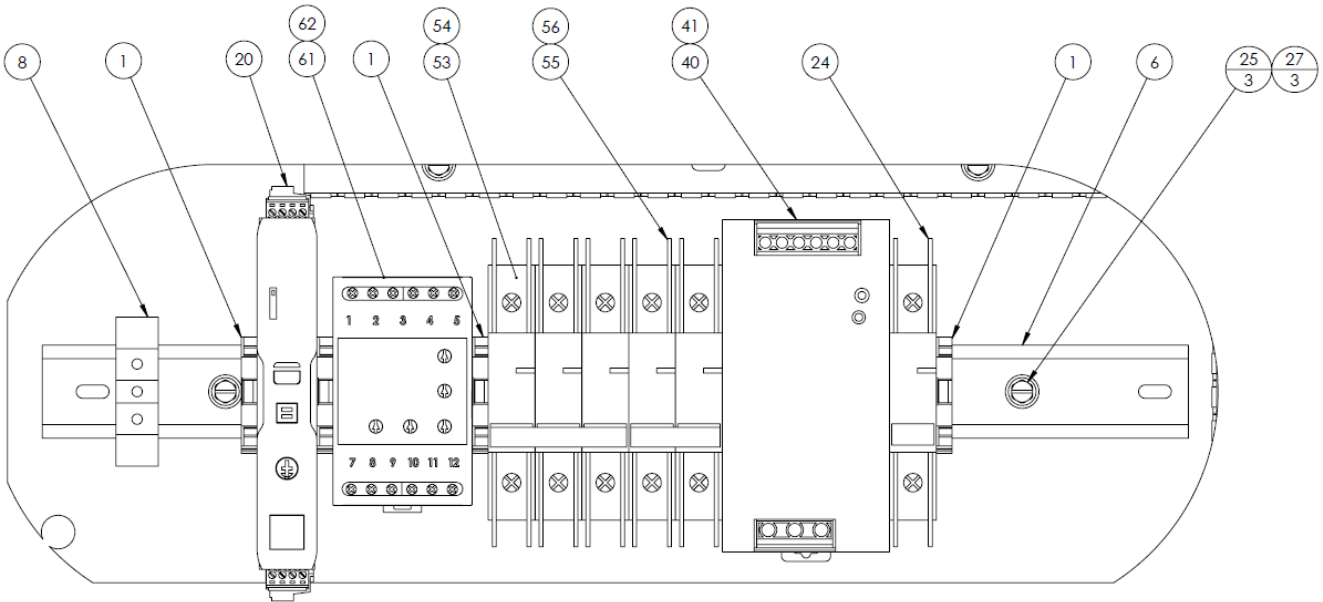
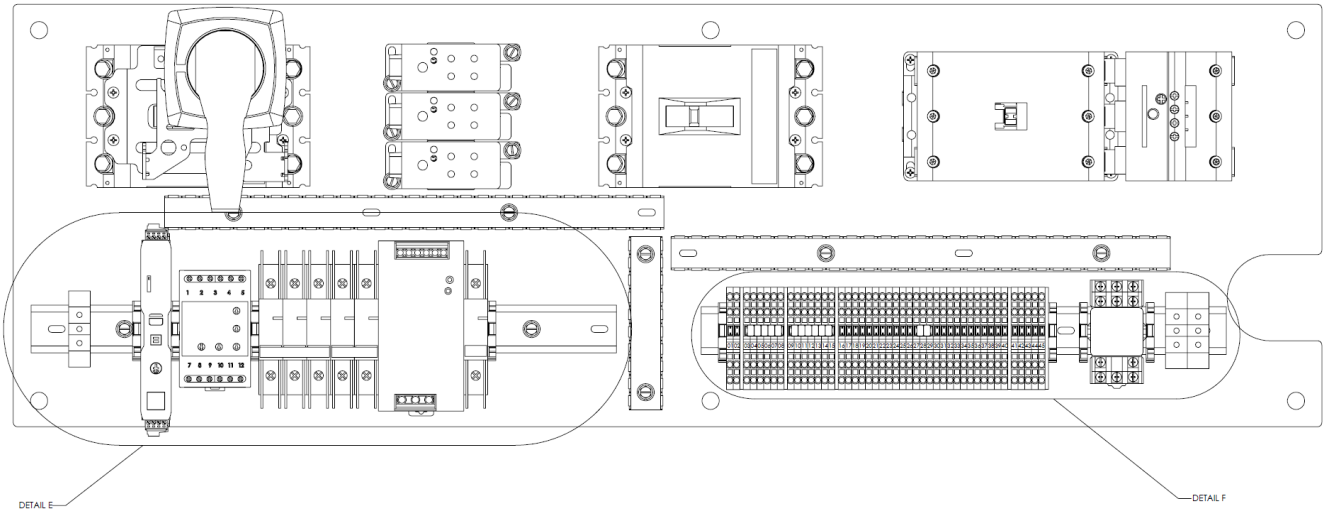

9.13 ELECTRICAL COMPONENTS (continued)

Parts List
All Fluid Types

Item	Part Number	Description	Qty
1	13070	ANCHOR DINRAIL END	8
2	EC-1710-06-10.0	DUCT, WIRING	1
3	EC-1710-06-14.5	DUCT, WIRING	2
4	EC-1711-02-14.5	COVER, WIRING DUCT	2
5	EC-1711-02-5.0	COVER, WIRING DUCT	1
6	EC-1895-017.00	RAIL, DIN	1
7	EC-1895-015.25	RAIL, DIN	1
8	EC-1957	BLOCK, GROUNDING	3
9	EC-2062	TERMINAL BLOCK, 4 COND (BLUE)	33
10	EC-2072	JUMPER, 2 CONDUCTOR	13
11	EC-2077	CARD, MARKING TERMINAL BLOCK	1
12	EC-2078	CARD, MARKING TERMINAL BLOCK	1
13	EC-2079	CARD, MARKING TERMINAL BLOCK	1
14	EC-2083	TERMINAL BLOCK, 4 COND LT GRAY	7
15	EC-2085	PLATE, END 4C TERMINAL BLOCK	5
16	EC-2453	CARD, MARKING TERMINAL BLOCK	1
17	EC-2454	CARD, MARKING TERMINAL BLOCK	1
18	EC-2923	BLOCK, TERMINAL GROUNDING	5
19	EC-3795	BLOCK, DISTRIBUTION 175A	3
21	EC-3819	SOCKET, RELAY	1
22	EC-3823-00	ENCLOSURE, ELECTRICAL (P)	1
23	EC-3833	RELAY, LATCHING	1
24	EC-3881	CIRCUIT BREAKER, 1P, 10A	1
25	G-1180-103502	SCR, #10 X 1/2, HEX HD TPG TYPE F	18
26	G-1202-1070	STOPNUT, 3/8-16 ELASTIC	6
27	G-1250-1030N	FLATWASHER, #10 NARROW	11
28	G-1515-M40	FLAT WASHER, M4	6
29	G-1546-040020	SCREW, PAN HEAD CROSS RECESSED, METRIC	12
30	S-4945	PANEL, ELECTRICAL INNER	1

9.13 ELECTRICAL COMPONENTS (continued)

THE FOLLOWING PARTS ARE APPLICATION SPECIFIC

Be sure to locate the correct voltage and hertz of the unit before selecting the part

Item	380 V – 60 Hz 380 V – 60 Hz 415 V – 50 Hz	460 V – 60 Hz 440 V – 50 Hz	575V – 60 Hz	Description	Qty
20	EC-3805	EC-3805	---	STARTER, MOTOR (2 WITH ELEC. FILL PUMP)	1
31	---	---	---	WIRE, THHN, 6 AWG, BLK	
32	---	EC-1263-06*72.0	EC-1263-06*72.0	WIRE, THHN, 4 AWG, BLK	4
33	EC-1263-08*72.0	---	---	WIRE, THHN, 2 AWG, BLK	4
34	---	---	EC-1541-03	FUSEHOLDER, MODULAR	1
35	---	---	EC-1542-03	FUSE, LP-CC 0.8A	2
36	---	---	---	WIRE, THHN, 6 AWG, GRN/YEL	
37	---	EC-1572-06*60.0	EC-1572-06*60.0	WIRE, THHN, 4 AWG, GRN/YEL	
38	---	EC-1572-06*60.0	EC-1572-06*60.0	WIRE, THHN, 4 AWG, GRN/YEL	1
39	EC-1572-08*60.0	---	---	WIRE, THHN, 2 AWG, GRN/YEL	1
40	EC-3620	EC-3620	---	24V POWER SUPPLY, 10A	1
41	---	---	EC-3772	24V POWER SUPPLY, 10A, 320-575	1
42	---	---	EC-3865	CIRCUIT BREAKER, 0.63-1.0A	1
43	---	---	---	OVERLOAD, 45-65A	1
44	EC-3868	---	---	OVERLOAD, 95-130A	
45	---	EC-3869	EC-3869	OVERLOAD, 70-95A	1
46	---	EC-3870	EC-3870	CIRCUIT BREAKER, 100A	1
47	EC-3871	---	---	CIRCUIT BREAKER, 150A	2
48	---	---	---	CIRCUIT BREAKER, 70A	2
49	EC-3873	---	---	CONTACTOR, 150A, 24VDC	
50	---	EC-3874	EC-3874	CONTACTOR, 100A, 24VDC	1
51	---	---	---	CONTACTOR, 65A, 24VDC	1
52	---	---	EC-3876	CONTACTOR, 9A, 24VDC	
53	EC-3877	---	---	CIRCUIT BREAKER, 3P, 5A	1
54	---	EC-3878	---	CIRCUIT BREAKER, 3P, 3A	1
55	EC-3879	---	---	CIRCUIT BREAKER, 2P, 4A	1
56	---	EC-3880	---	CIRCUIT BREAKER, 2P, 2A	1
57	---	EC-3882	EC-3882	HANDLE ASSEMBLY, 100A SERIES	1
58	EC-3883	---	---	HANDLE ASSEMBLY, 150A SERIES	1
59	---	EC-3891	EC-3891	SHAFT, 100A BREAKER	1
60	EC-3892	---	---	SHAFT, 150A BREAKER	1
61	EC-3905	EC-3905	---	PHASE MONITOR RELAY, 190-500VAC	1
62	---	---	EC-3949	PHASE MONITOR RELAY, 480-600VAC	1
63	S-4950-00	---	---	COVER, ELECTRICAL BOX (P)	1
64	---	S-4951-00	S-4951-00	COVER, ELECTRICAL BOX (P)	8

9.13 ELECTRICAL COMPONENTS *(continued)*

75 HP AMPS				
VOLTS	FREQUENCY	AMPS	HEAT EXCH. AMPS	FILL PUMP AMPS
380	60	106	0.5	1.5
460	60	92	0.4	1.1
575	60	74	0.3	0.9
380	50	107	0.6	1.7
415	50	105	0.6	1.7
440	50	92	0.5	1.5

9.14 HEAT EXCHANGER ASSEMBLY

The Heat Exchanger Assembly does not require regular general maintenance.

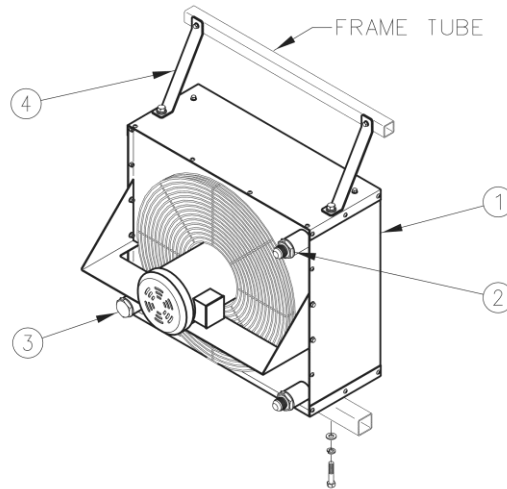

Model Number	Fluid Type
5711	MIL-PRF-5606
5721	MIL-PRF-83282
5731	Aviation Phosphate Ester, Skydrol
5751	Aviation Phosphate Ester, HyJet

Item	5711 & 5721	5731 & 5751	Description	Qty
	Part Number	Part Number		
1	Reference Table below	Reference Table below	HEAT EXCHANGER	1
2	N-2007-27-S-B	N-2007-27-S-E	CONNECTOR, #20 SAE X #16 JIC	1
3	N-2066-20-S-B	N-2066-20-S-E	PLUG, O-RING #20	1
4	J-3404-01	J-3404-01	STRAP	2

Voltage	Frequency	Part Number
380V	60 Hz	HC-2137-01
460V	60 Hz	HC-2137-01
575V	60 Hz	HC-2137-02
380V	50 Hz	HC-2137-01
415V	50 Hz	HC-2137-01
440V	50 Hz	HC-2137-01

9.15 EXTERNAL COMPONENTS

Keep HPU clean. Do not allow labels to become damaged; thusly illegible. Regularly inspect casters and floor locks to ensure safe working condition.

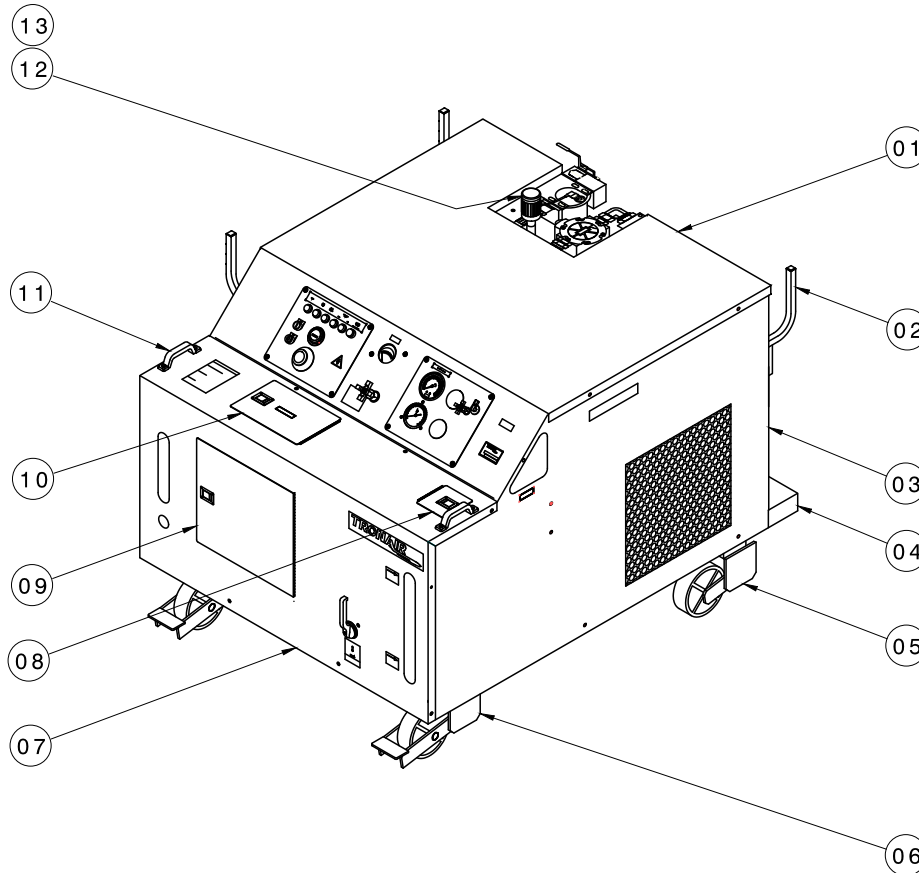

Parts List All Fluid Types

Item	Part Number	Description	Qty
1	S-1763-00	TOP PANEL	1
2	Z-5549-00	HANGER	3
3	Z-5362-00	RIGHT SIDE PANEL	1
4	S-1782-00	PANEL, END	1
5	U-1099	RIGID CASTER	2
6	U-1100	SWIVEL CASTER	2
7	Z-5408-00	FRONT PANEL	1
8	Z-4781	FILLER DOOR	1
9	Z-5576	FRONT ACCESS DOOR	1
10	Z-4783	PUMP ACCESS DOOR	1
11	H-1780	HANDLE	2
12	EC-1794	BOX, VERTICAL MOUNT JUNCTION (OPTIONAL)	1
13	EC-1791	LIGHT, POLE MOUNTED STACK (OPTIONAL)	1
N/S	Z-5367-00	LEFT SIDE PANEL	1
N/S	Z-5165-00	FRAME	1
N/S	S-1703-00	ELECTRICAL BOX COVER	1

9.16 ADDITIONAL FEATURES

9.16.1 50 ft (15.2 m) Hoses (*Option B*)

Refer to Section 9.6 Hydraulic Hoses concerning hose inspection.

Model Number	Fluid Type
5711	MIL-PRF-5606
5721	MIL-PRF-83282
5731	Aviation Phosphate Ester
5751	Aviation Phosphate Ester

5711 & 5721		5731 & 5751	
Part Number	Part Number	Description	Qty
TF-1038-28*300	TF-1040-05*300	PRESSURE HOSE, 25 FT/7.6 M	2 per Option
TF-1039-12*300	TF-1041-04*300	RETURN HOSE, 25 FT/7.6 M	2 per Option
N-2011-10-S	N-2011-10-S	UNION, #16	1 per Option
N-2011-12-S	N-2011-12-S	UNION, #12	1 per Option

9.16.2 Split System (Option C)

Refer to Section 9.6 Hydraulic Hoses concerning hose inspection.

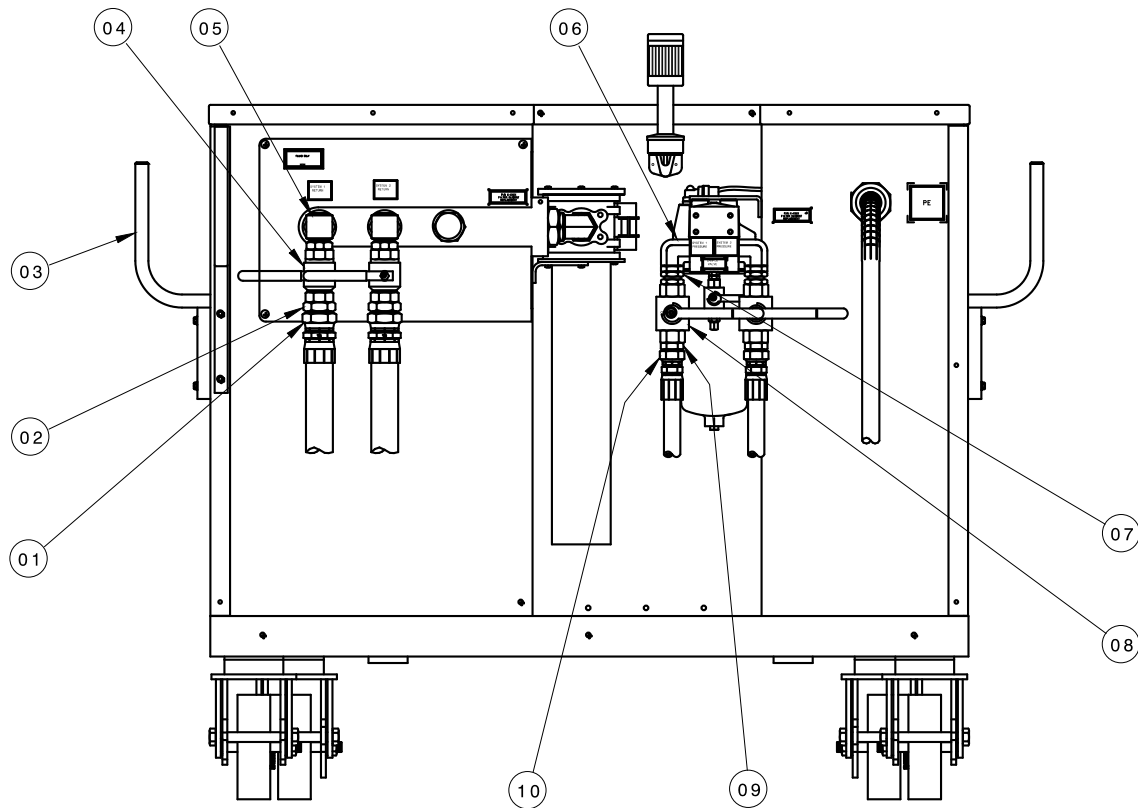

Model Number	Fluid Type
5711	MIL-PRF-5606
5721	MIL-PRF-83282
5731	Aviation Phosphate Ester, Skydrol
5751	Aviation Phosphate Ester, HyJet

Item	5711 & 5721	5731 & 5751	Description	Qty
	Part Number	Part Number		
1	TF-1039-12*300	TF-1041-04*300	ASSEMBLY, HOSE #24	1
2	N-2007-31-S-B	N-2007-31-S-E	CONNECTOR, STRAIGHT THREAD	1
3	Z-5549-01	Z-5549-01	WELDMENT, HOSE HANGER	2
4	HC-2266-24	HC-3042-24	VALVE, BALL	1
5	N-2666-08-S-B	N-2666-08-S-E	ELBOW, STRAIGHT THREAD #24	1
6	N-2661-06-S-B	N-2661-06-S-E	ELBOW, STRAIGHT THREAD	1
7	N-2464-10-S-B	N-2464-10-S-E	UNION, #16 STRAIGHT THREAD	1
8	HC-1768-05	HC-1771-05	VALVE, BALL	1
9	N-2007-24-S-B	N-2007-24-S-E	CONNECTOR, STRAIGHT THREAD	1
10	TF-1038-28*300	TF-1040-05*300	ASSEMBLY, HOSE #16	1

9.16.3 Pyrometer

Refer to Section 11.7 – Analog Temperature Gauge when calibration of the pyrometer is desired.

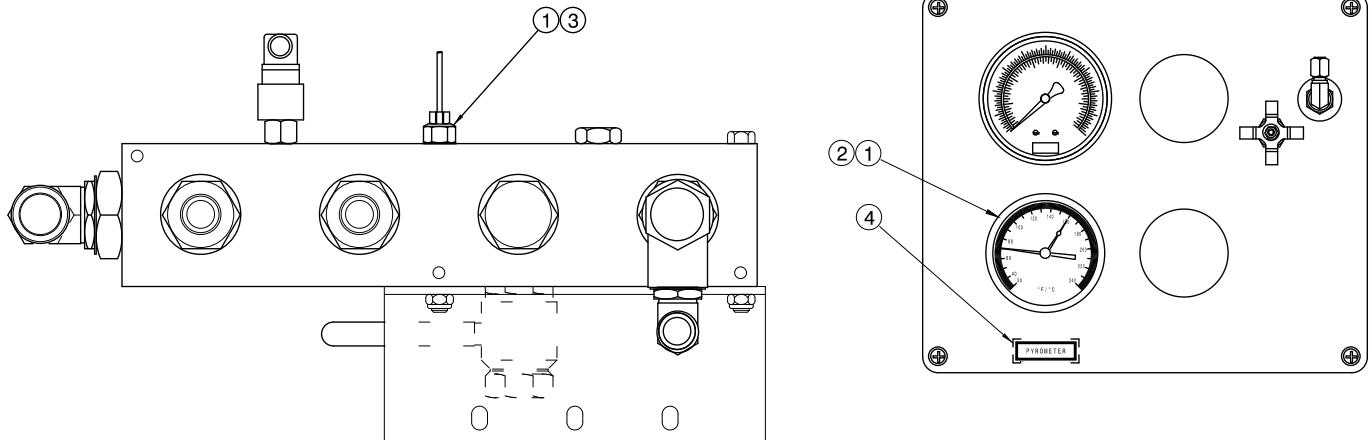

Model Number	Fluid Type
5711	MIL-PRF-5606
5721	MIL-PRF-83282
5731	Aviation Phosphate Ester, Skydrol
5751	Aviation Phosphate Ester, HyJet

Item	5711 & 5721	5731 & 5751	Description	Qty
	Part Number	Part Number		
1	HC-2268-01	HC-2268-02	GAUGE, PYROMETER	1
2	S-1158-01	S-1158-01	COVER, THERMOMETER OPENING	Ref
3	N-2053-08-S-B	N-2053-08-S-E	PLUG, HEX HEAD W/O-RING	Ref
4	V-1886	V-1886	LABEL, PYROMETER	1

9.16.4 Electric Reservoir Level (*Option L*)

The Electric Reservoir Level switch does not require regular general maintenance. Panel indicator lights will indicate low or high fluid level.

NOTE: Wire per Electrical Schematic INS-2016. Reference Wiring Diagram INS-1597. Reference 9.7.1 Electrical Panel for Panel Light.

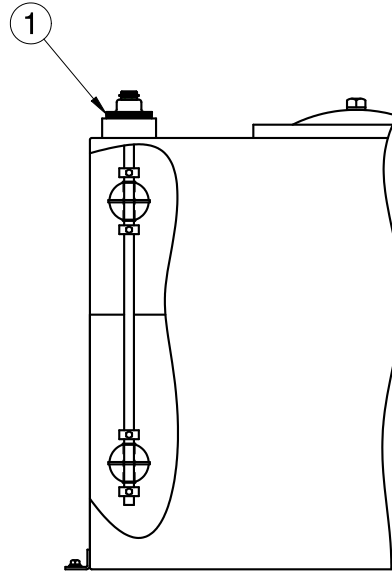

Parts List
All Fluid Types

Item	Part Number	Description	Qty
1	EC-1783	Multi-Level Switch (includes Plug-in Cable)	1

9.16.5 Hand Pump (Option M)

Refer to Section 9.6 Hydraulic Hoses concerning hose inspection for general maintenance on Items 4, 5, 7 and 13 hose assemblies. Refer to Section 9.5.3 – Hand Pump (Optional) Filter .

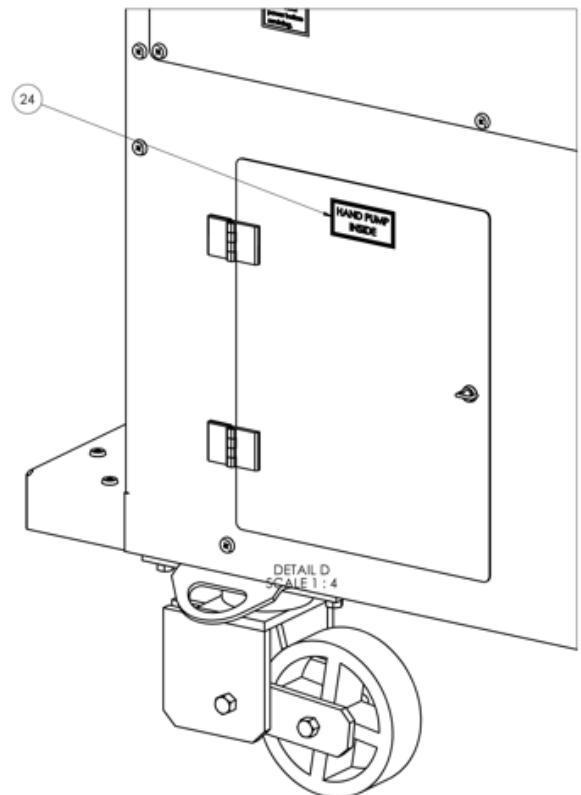
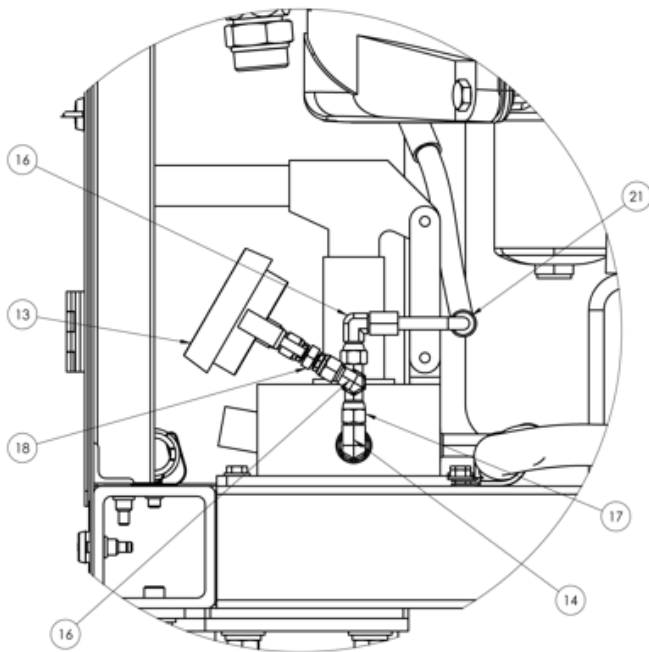
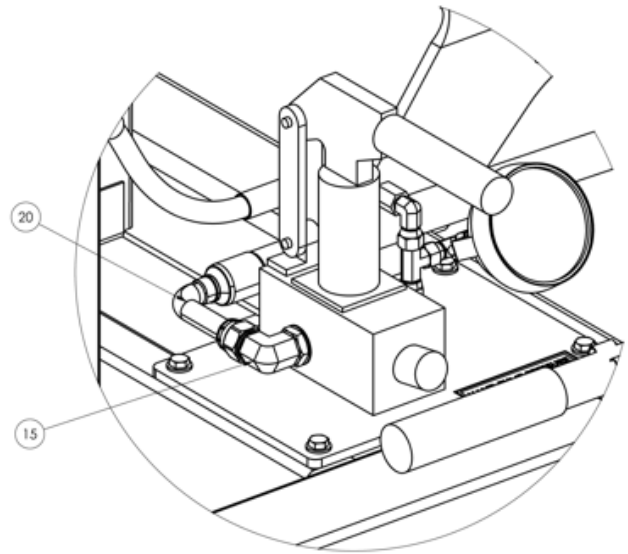
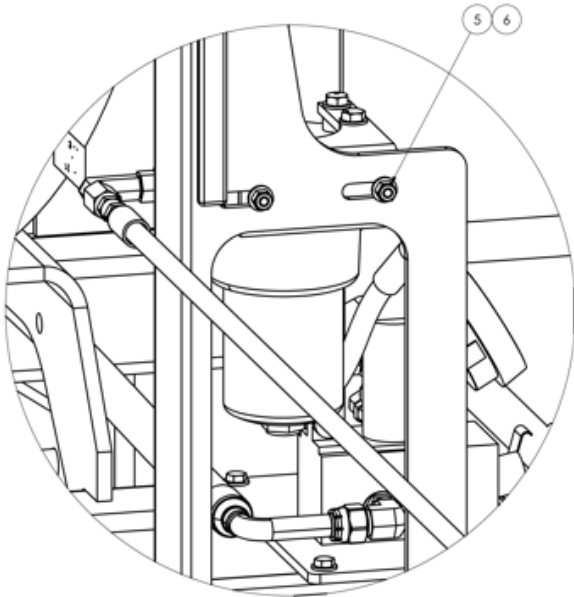

9.16.5 Hand Pump (Option M)(continued)

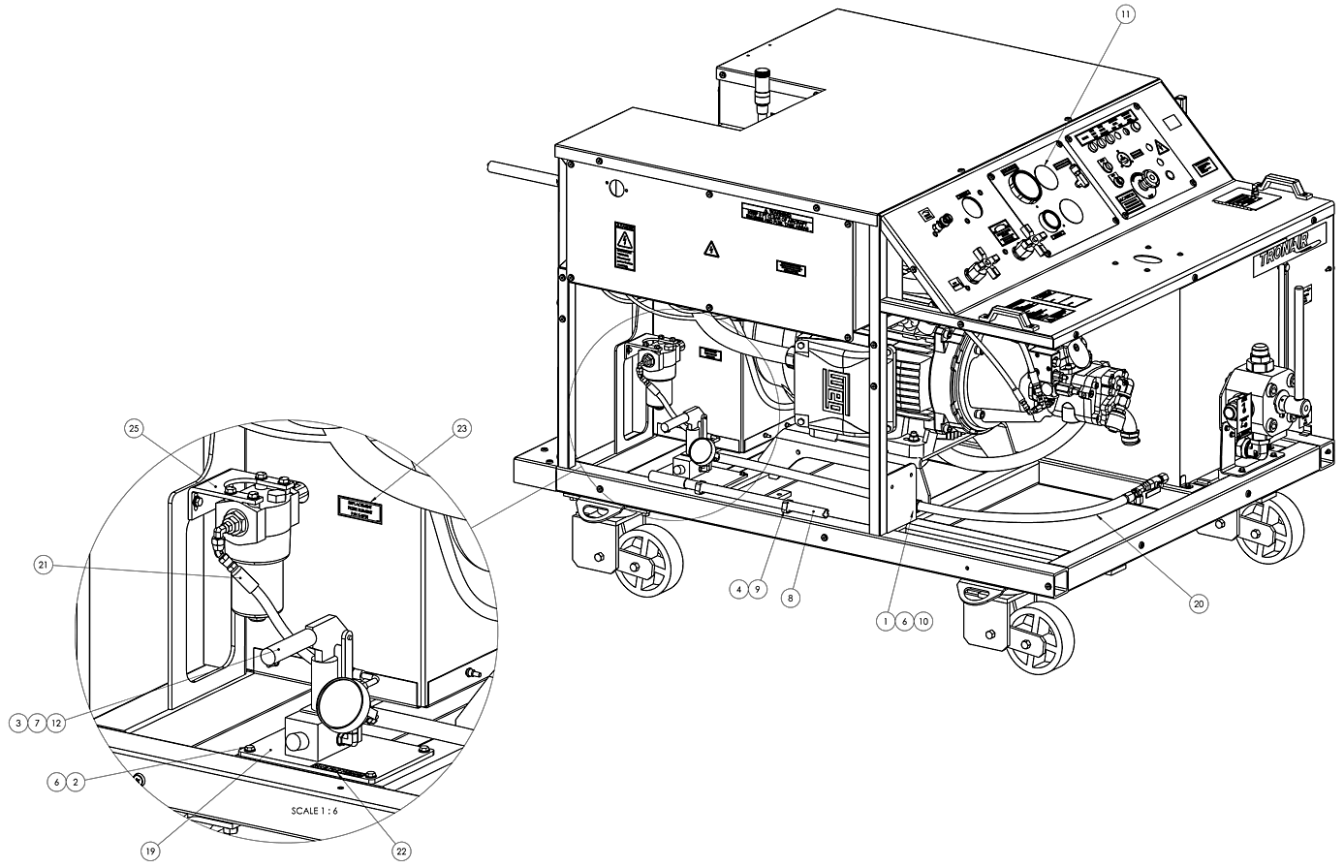

9.16.5 Hand Pump (Option M)(continued)

Model Number	Fluid Type
5711	MIL-PRF-5606
5721	MIL-PRF-83282
5731	Aviation Phosphate Ester, Skydrol
5751	Aviation Phosphate Ester, HyJet

Item	5711 & 5721	5731 & 5751	Description	Qty
	Part Number	Part Number		
1	G-1100-105007	G-1100-105007	BOLT, 1/4-20 X 7/8" LG HEX HD GR 5	1
2	G-1100-105012	G-1100-105012	BOLT, 1/4-20 X 1-1/4" LG HEX HD GR 5	4
3	G-1100-107010	G-1100-107010	BOLT, 3/8-16 X 1.0" HEX HD GR 5	2
4	G-1157-103504	G-1157-103504	SCREW, #10-32 X 1/2" PAN HD CRS RECESS	2
5	G-1202-1050	G-1202-1050	STOPNUT, 1/4-20 ELASTIC	2
6	G-1250-1050N	G-1250-1050N	FLATWASHER, 1/4 NARROW	7
7	G-1250-1070N	G-1250-1070N	FLATWASHER, 3/8 NARROW	2
8	H-1009-01	H-1009-01	HANDLE, PUMP (P)	1
9	H-1438-02	H-1438-02	HOLDER, SPRING CLIP	2
10	H-1721-13	H-1721-13	CLAMP, ELECTRICAL	1
11	H-2432-15	H-2432-15	PLUG, SHEETMETAL (PAINTED) (P)	1
12	HC-1778	HC-1779	PUMP, 2 STAGE HYDRAULIC HAND (MB)	1
13	HC-2146	HC-2146	GAUGE, PRESSURE 10000 PSI	1
14	N-2001-05-S-B	N-2001-05-S-E	ELBOW, STRAIGHT THREAD	1
15	N-2001-11-S-B	N-2001-11-S-E	ELBOW, STRAIGHT THREAD	1
16	N-2002-03-S	N-2002-03-S	ELBOW, SWIVEL NUT	2
17	N-2016-03-S	N-2016-03-S	TEE, RUN SWIVEL NUT	1
18	N-2697-01-S	N-2697-01-S	UNION, SWIVEL NUT	1
19	S-4794-00	S-4794-00	MOUNTING PLATE, HAND PUMP	1
20	TF-1037-12-62.0	TF-1041-14-62.0	ASSEMBLY, HOSE #8	1
21	TF-1038-15-15.0	TF-1041-53-15.0	HYDRAULIC HOSE	1
22	V-1887	V-1887	LABEL, HAND PUMP PRESSURE	1
23	V-1988	V-1989	LABEL, K-3751 FILTER REPLACEMENT	1
24	V-2929	V-2929	LABEL, HAND PUMP INSIDE	1
25	Z-12657-01	Z-12657-02	ASSEMBLY, HANDPUMP FILTER	1

9.16.6 Hand Pump High Displacement (*Option M-7*)

Refer to Section 9.6 Hydraulic Hoses concerning hose inspection for general maintenance on Items 3, 4, 11, 18 and 23 hose assemblies. Refer to Section 9.5.3 – Hand Pump (Optional) Filter.

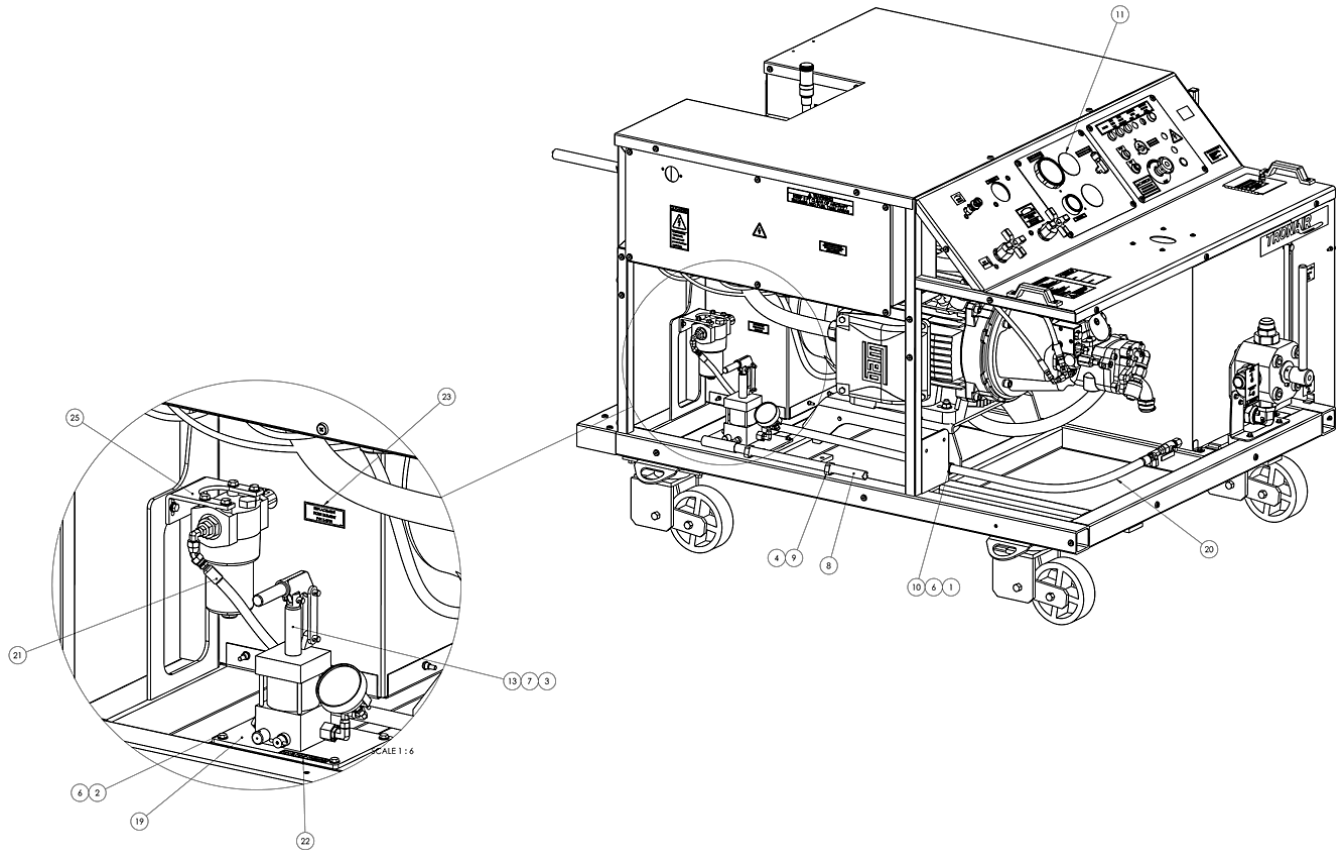

9.16.6 Hand Pump High Displacement (Option M-7) (continued)

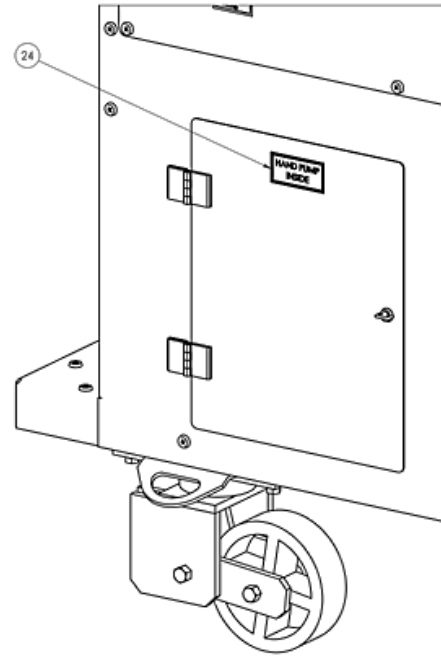
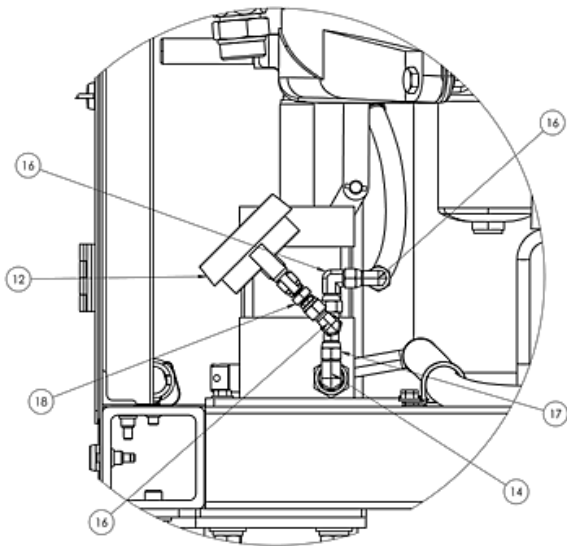
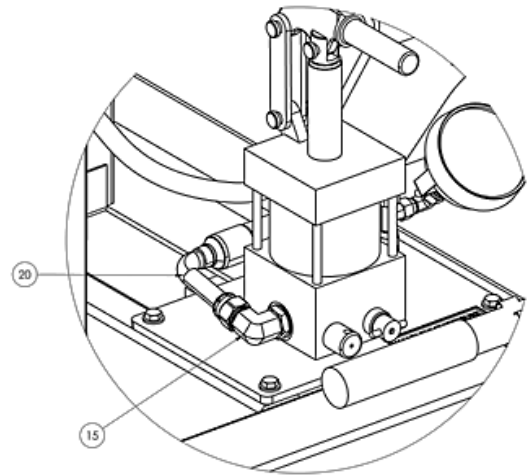
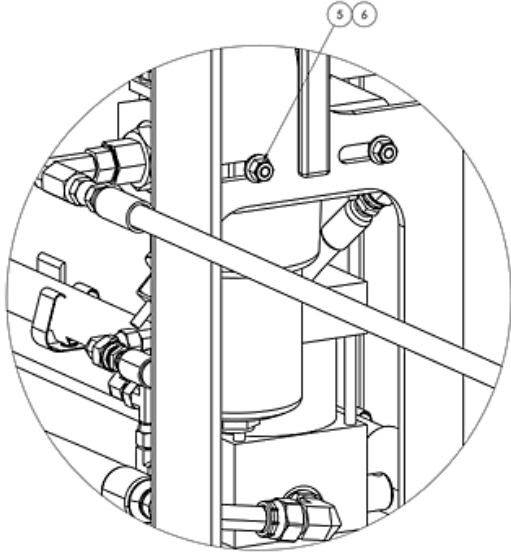

9.16.6 Hand Pump High Displacement (Option M-7) (continued)

Model Number	Fluid Type
5711	MIL-PRF-5606
5721	MIL-PRF-83282
5731	Aviation Phosphate Ester, Skydrol
5751	Aviation Phosphate Ester, HyJet

Item	5711 & 5721	5731 & 5751	Description	Qty
	Part Number	Part Number		
1	G-1100-105007	G-110-105007	BOLT, 1/4-20 X 7/8" LG HEX HD GR 5	1
2	G-1100-105012	G-1100-105012	BOLT, 1/4-20 X 1-1/4" LG HEX HD GR 5	4
3	G-1100-107010	G-100-107010	BOLT, 3/8-16 X 1.0" HEX HD GR 5	2
4	G-1157-103504	G-1157-103504	SCREW, #10-32 X 1/2" PAN HD CRS RECESS	2
5	G-1202-1050	G-1202-1050	STOPNUT, 1/4-20 ELASTIC	2
6	G-1250-1050N	G-1250-1050N	FLATWASHER, 1/4 NARROW	7
7	G-1250-1070N	G-1250-1070N	FLATWASHER, 3/8 NARROW	2
8	H-1009-01	H-1009-01	HANDLE, PUMP (P)	1
9	H-1438-02	H-1438-02	HOLDER, SPRING CLIP	2
10	H-1721-13	H-1721-13	CLAMP, ELECTRICAL	1
11	H-2432-15	H-2432-15	PLUG, SHEETMETAL (PAINTED) (P)	1
12	HC-2146	HC-2146	GAUGE, PRESSURE 10000 PSI	1
13	HC-2577	HC-2970	PUMP, HYDRAULIC HAND (MB)	1
14	N-2001-05-S-B	N-2001-05-S-E	ELBOW, STRAIGHT THREAD	1
15	N-2001-11-S-B	N-2001-11-S-E	ELBOW, STRAIGHT THREAD	1
16	N-2002-03-S	N-2002-03-S	ELBOW, SWIVEL NUT	3
17	N-2016-03-S	N-2016-03-S	TEE, RUN SWIVEL NUT	1
18	N-2697-01-S	N-2697-01-S	UNION, SWIVEL NUT	1
19	S-4794-00	S-4794-00	MOUNTING PLATE, HAND PUMP	1
20	TF-1037-12-62.0	TF-1041-14-62.0	ASSEMBLY, HOSE #8	1
21	TF-1038-14-14.0	TF-1041-05-14.0	ASSEMBLY, HOSE #4	1
22	V-1887	V-1887	LABEL, HAND PUMP PRESSURE	1
23	V-1988	V-1989	LABEL, K-3751 FILTER REPLACEMENT	1
24	V-2929	V-2929	LABEL, HAND PUMP INSIDE	1
25	Z-12657-01	Z-12657-02	ASSEMBLY, HANDPUMP FILTER	1

9.16.7 Electric Fill Pump (Option M-E and M-F)

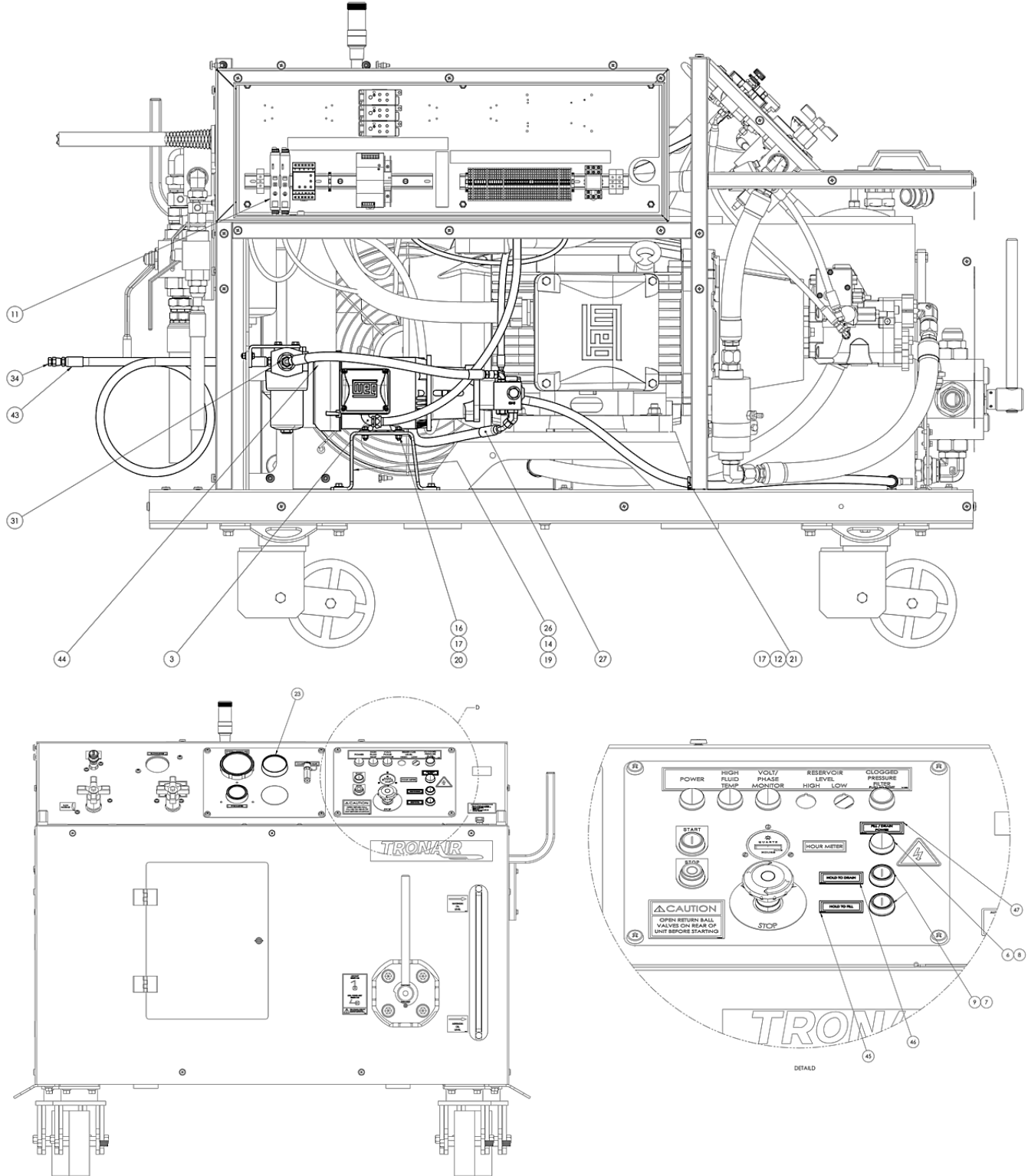

9.16.7 Electric Fill Pump (Option M-E and M-F) (continued)

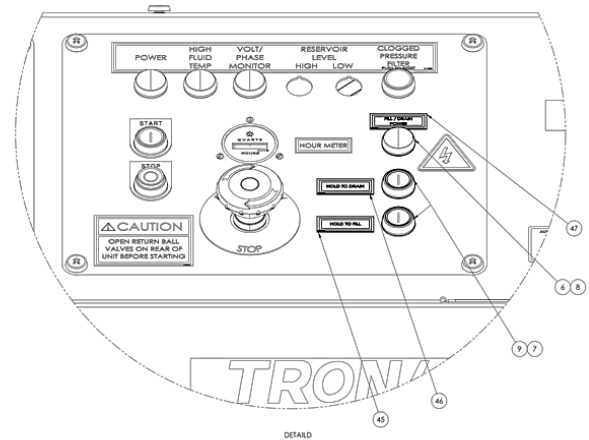
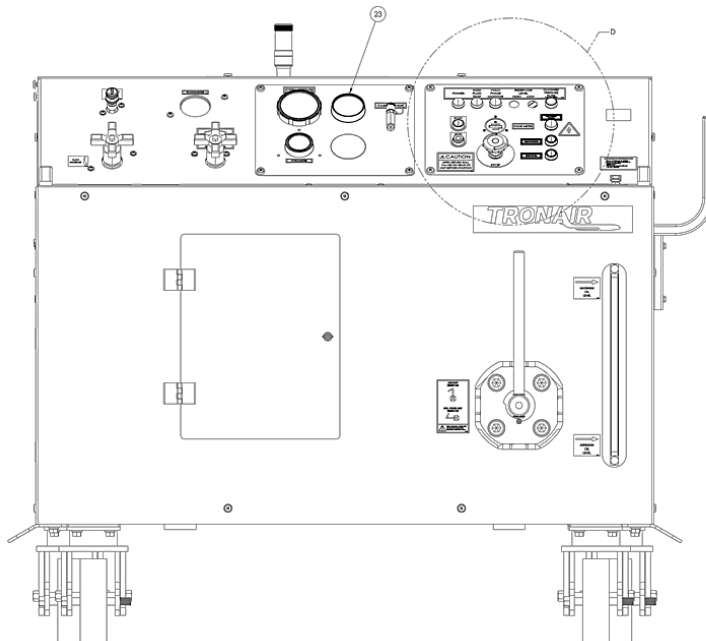
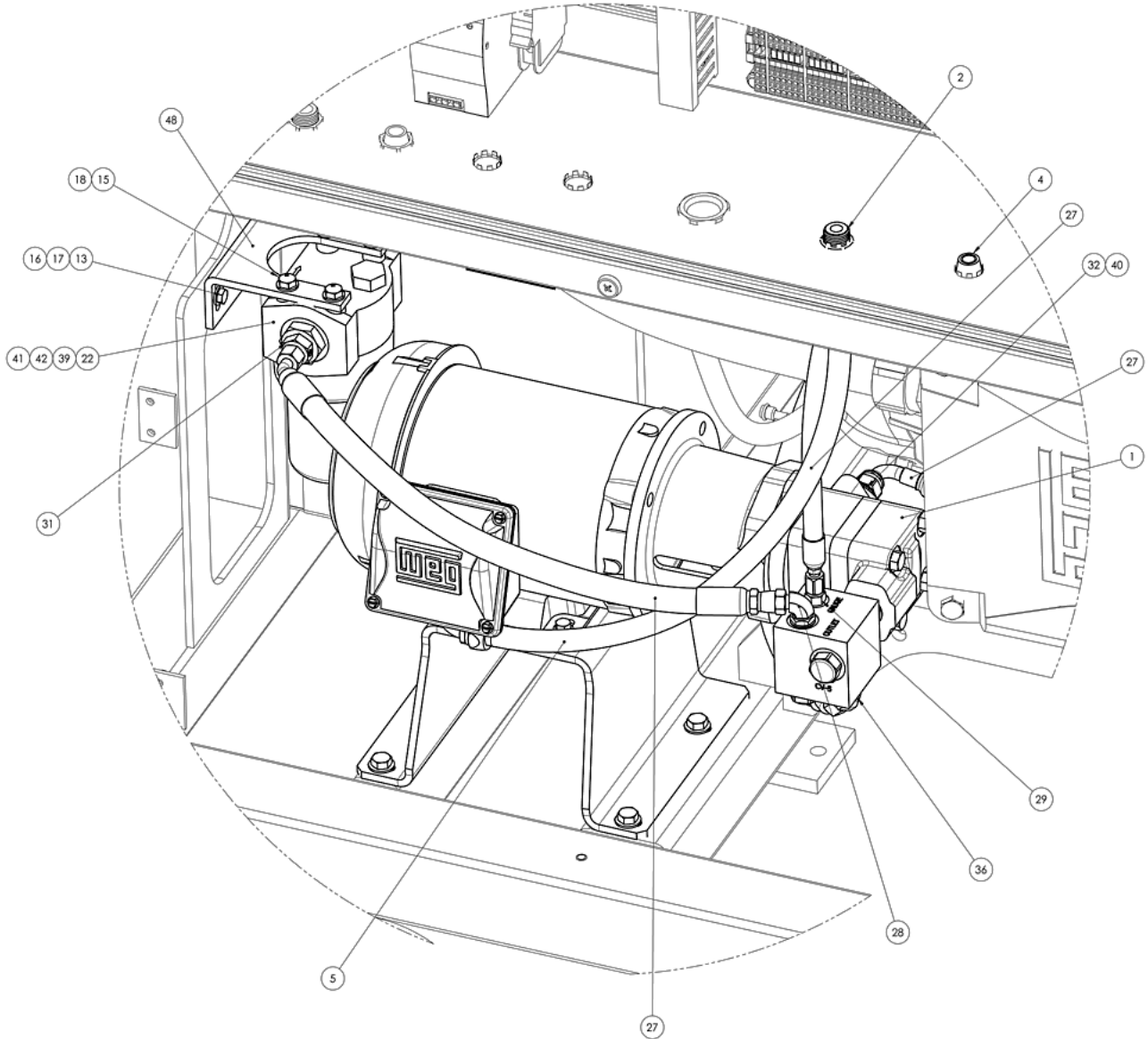

9.16.7 Electric Fill Pump (Option M-E and M-F) (continued)

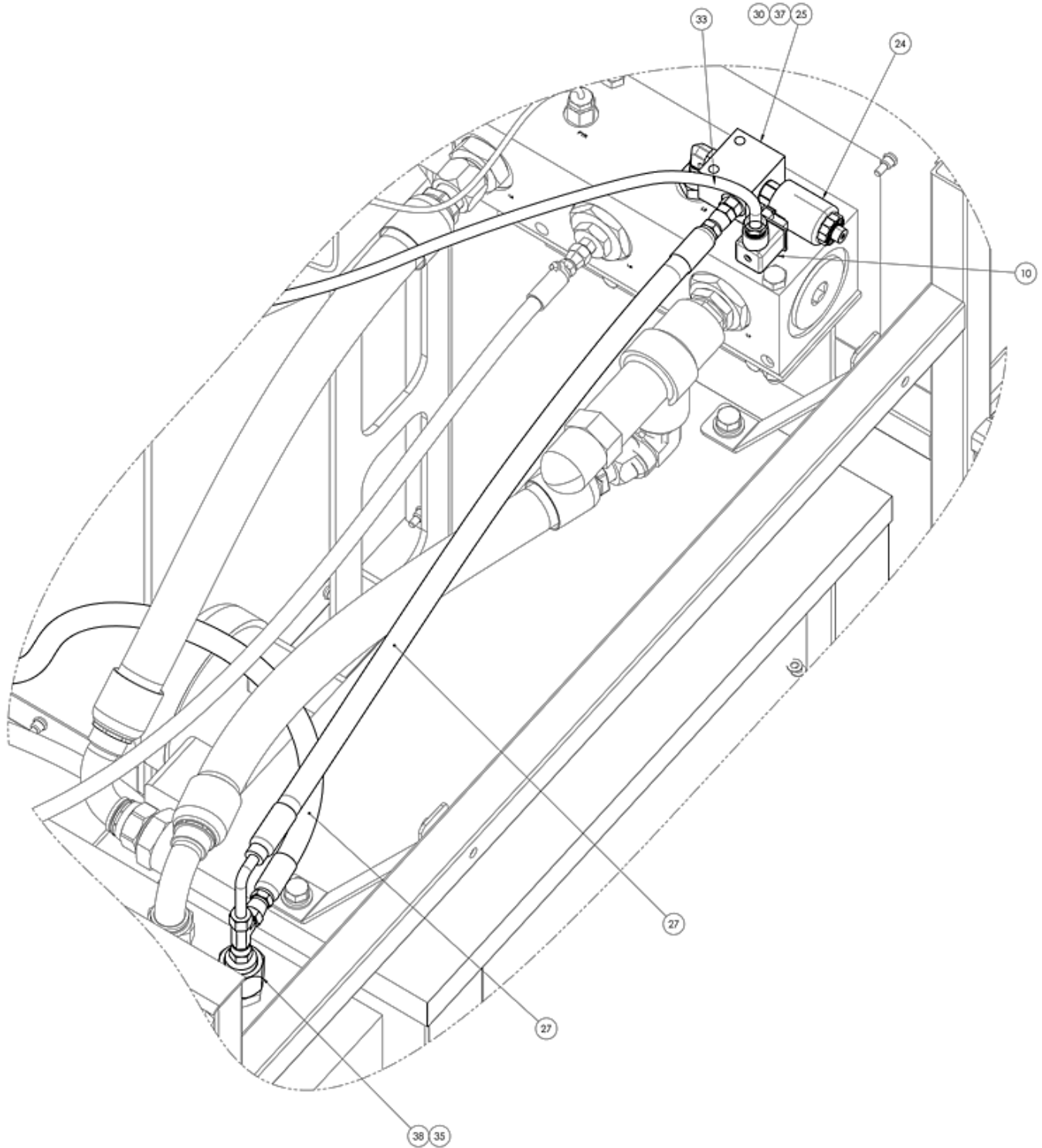

9.16.7 Electric Fill Pump (Option M-E and M-F) (continued)

Model Number	Fluid Type
5711	MIL-PRF-5606
5721	MIL-PRF-83282
5731	Aviation Phosphate Ester, Skydrol
5751	Aviation Phosphate Ester, HyJet

Item	5711 & 5721	5731 & 5751	Description	Qty
	Part Number	Part Number		
1	SEE PUMP ASSEMBLY TABLE		PUMP MOTOR, ELECTRIC FILL (P)	1
2	EC-1167-01	EC-1167-01	CONNECTOR, NYLON INSULATED CONDUIT	1
3	EC-1168-01	EC-1168-01	ELBOW, 90 DEG CONDUIT 3/8" (1/2" HUB)	1
4	EC-1175-06-A	EC-1175-06-A	CONNECTOR, POWER CABLE 1/2IN	1
5	EC-1187-03-27.0	EC-1540-01-27.0	CONDUIT, FLEXIBLE WIRING	1
6	EC-1945-01	EC-1945-01	LIGHT, DIFFUSED PILOT	1
7	EC-1946-MX20	EC-1946-MX20	POWER MODULE W/ LATCH	2
8	EC-1951-MN3G	EC-1951-MN3G	POWER MODULE WITH LATCH	1
9	EC-1953-MF306	EC-1953-MF306	PUSH BUTTON, NON-ILLUMINATED	2
10	EC-2198	EC-2198	CABLE, DIN CONNECTOR	1
11	SEE MOTOR CONTROLLER TABLE		STARTER, MOTOR	1
12	G-1100-105007	G-1100-105007	BOLT, 1/4-20 X 7/8" LG HEX HD GR 5	1
13	G-1100-105010	G-1100-105010	BOLT, 1/4-20 X 1.0" LG HEX HD GR 5	6
14	G-1100-107010	G-1100-107010	BOLT, 3/8-16 X 1.0" HEX HD GR 5	4
15	G-1114-080016	G-1114-080016	BOLT M8-1.25 X 16mm LG. CLASS 8.8	4
16	G-1202-1050	G-1202-1050	STOPNUT, 1/4-20 ELASTIC	6
17	G-1250-1050N	G-1250-1050N	FLATWASHER, 1/4 NARROW	13
18	G-1250-1060N	G-1250-1060N	FLATWASHER, 5/16 NARROW	4
19	G-1250-1070N	G-1250-1070N	FLATWASHER, 3/8 NARROW	4
20	G-1502-1050R	G-1502-1050R	LOCKWASHER, 1/4 SST REGULAR	4
21	H-1721-10	H-1721-10	CLAMP, ELECTRICAL	1
22	HC-1776	HC-1777	FILTER, PRESSURE (PE)	1
23	HC-2188	HC-2188	GAUGE, PRESSURE 300 PSI	1
24	HC-3084	HC-3080	VALVE, SOLENOID, NC, 24VDC	1
25	HC-3081	HC-3081	MANIFOLD, HYDRAULIC	1
26	J-9070-00	J-9070-00	PUMP MTG BKT	1
27	K-5873	K-5871	KIT, FILL PUMP HOSES	1
28	N-2001-08-S-B	N-2001-08-S-E	ELBOW, STRAIGHT THREAD	1
29	N-2007-03-S-B	N-2007-03-S-E	CONNECTOR, STR THD	1
30	N-2007-08-S-B	N-2007-08-S-E	CONNECTOR, STR THD	1
31	N-2007-09-S-B	N-2007-09-S-E	CONNECTOR, MALE (06-08)	1
32	N-2007-11-S-B	N-2007-11-S-E	CONNECTOR, STR THD	1
33	N-2007-46-S-B	N-2007-46-S-E	CONNECTOR, STR THD	1
34	N-2014-05-S	N-2014-05-S	PLUG	1
35	N-2016-05-S	N-2016-05-S	TEE, RUN SWIVEL NUT	1
36	N-2042-19-S-B	N-2042-19-S-E	ELBOW, 45° -06 M JIC X -08 M ORB	1
37	N-2049-06-S-B	N-2049-06-S-E	ELBOW, 90 DEG SWIVEL	1
38	N-2055-17-S	N-2055-17-S	REDUCER, TUBE	1
39	N-2463-10-S-B	N-2463-10-S-E	ADAPTER, -12 SAE ORB M X -08 SAE ORB F	2
40	N-2463-16-S-B	N-2463-16-S-E	FITTING, REDUCER/EXPANDER	1
41	N-2463-29-S-B	N-2463-29-S-E	FITTING, REDUCER/EXPANDER	1

9.16.7 Electric Fill Pump (Option M-E and M-F) (continued)

Model Number	Fluid Type
5711	MIL-PRF-5606
5721	MIL-PRF-83282
5731	Aviation Phosphate Ester, Skydrol
5751	Aviation Phosphate Ester, HyJet

Item	5711 & 5721	5731 & 5751	Description	Qty
	Part Number	Part Number		
42	N-2706-02-S B	N-2706-02-S-E	ELBOW, LONG STR THD	1
43	TF-1038-14-300	TF-1041-02-300	ASSEMBLY, HOSE (#6)	1
44	V-2731	V-1988	LABEL, K-3751 FILTER REPLACEMENT	1
45	V-2641	V-2641	LABEL, FILL PUMP	1
46	V-3129	V-3129	LABEL, DRAIN PUMP	1
47	V-3130	V-3130	LABEL, FILL / DRAIN POWER	1
48	Z-5093-00	Z-5093-00	BRACKET, FILTER (P)	1

Model	Pump Assembly		Motor Controller		
	Pump Assembly	Voltage	Motor Controller	Motor Protector (A)	Contactactor (B)
5711 & 5721	HC-2797-00	200-460	EC-3805	-	-
	HC-3085-00	575	-	EC-3865	EC-3876
5731 & 5751	HC-2701-00	200-460	EC-3805	-	-
	HC-2709-00	575	-	EC-3865	EC-3876

9.16.8 Towing Trailer (Option N)

Capacity 4,000 lbs (1,814 kg)
 Front Axle Capacity 2,000 lbs (907 kg)
 Rear Axle Capacity 2,000 lbs (907 kg)
 Tires 4.80-8NHS x 6 Ply Rated at 970 lbs (440 kg) (105 psi at 10 mph/7.24 bar at 16 kph)

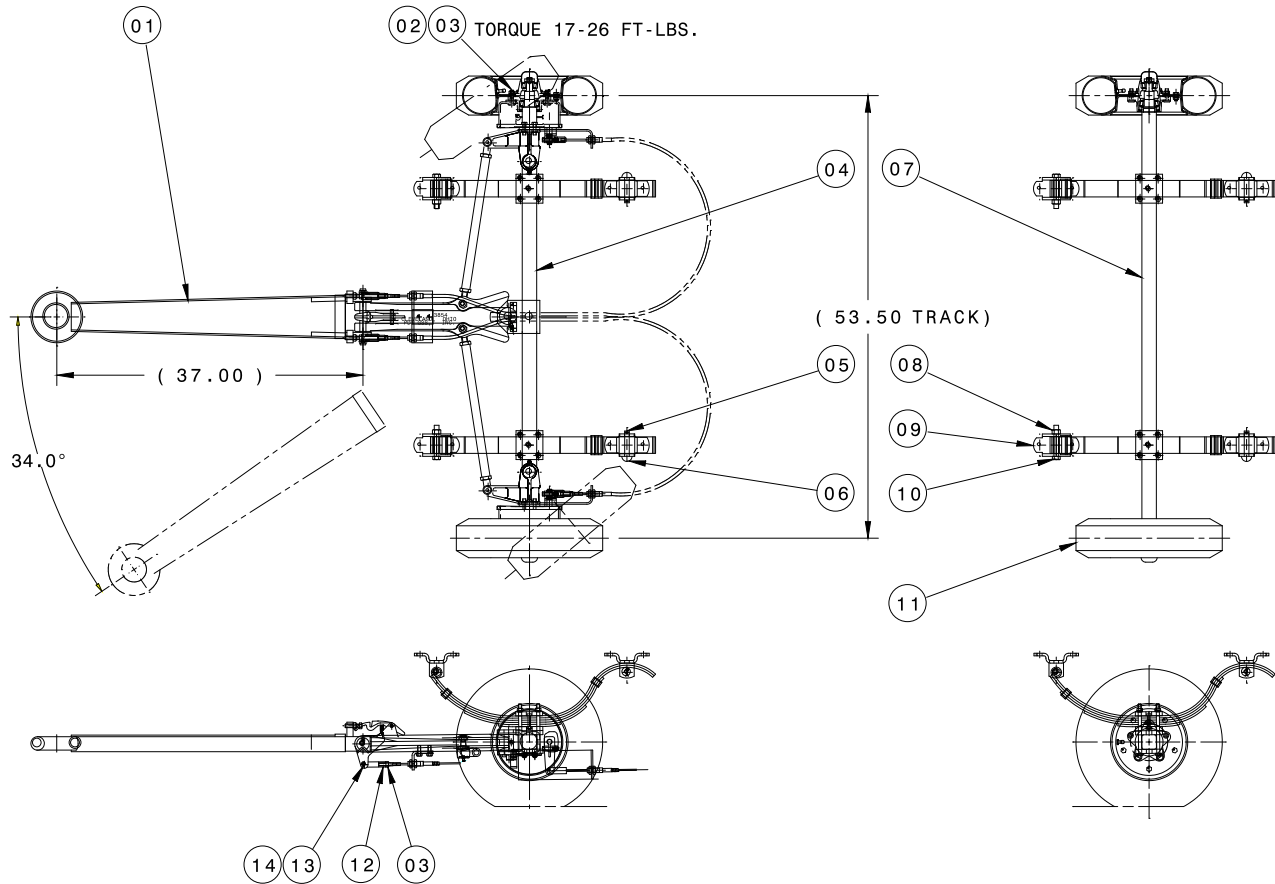

Parts List

All Fluid Types

Item	Part Number	Description	Qty
1	59-3502	ASSEMBLY, DRAWBAR	1
2	4700-4	LOCKWASHER (3/8)	20
3	4601-47	NUT, HEX HEAD (3/8-24)	22
4	6-1395	ASSEMBLY, FRONT AXLE	1
5	4800-3	PIN, COTTER	4
6	5403-1	RIVET	4
7	8-1345	ASSEMBLY, REAR AXLE	1
8	4601-33	NUT, SELF-LOCKING (9/16-12)	4
9	4251	BRACKET, SPRING	8
10	4901-19	BOLT (9/16-12 X 3¾")	4
11	5-3705	WHEEL AND TIRE ASSEMBLY	4
12	5205	YOKE	2
13	5206	PIN, YOKE	2
14	4800-2	PIN, COTTER (3/32 X ¾")	2

9.16.9 Stack Light (Option SL)

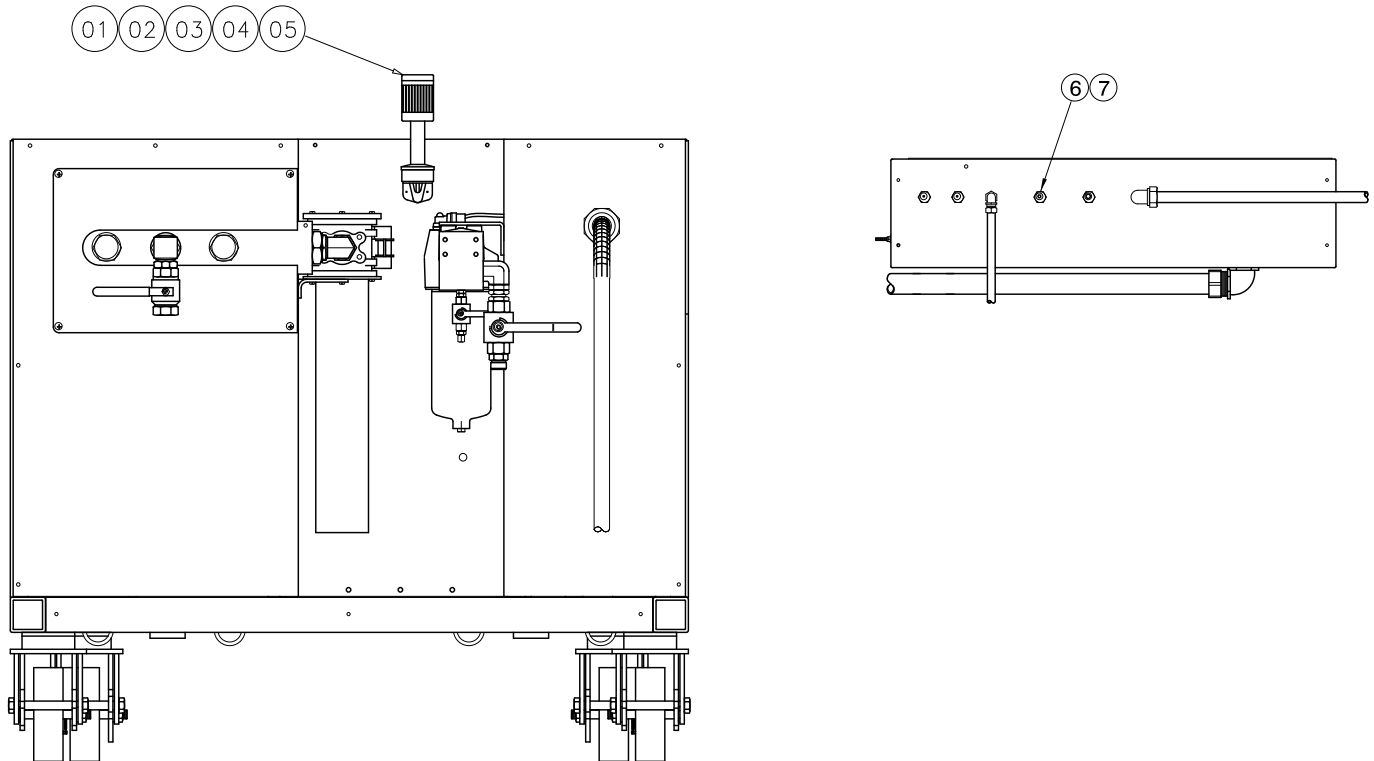

Parts List All Fluid Types

Item	Part Number	Description	Qty
1	Z-5664	ASSEMBLY, VERTICAL STACK LIGHT	1
2	H-1901-20	GROMMET, 1/2"	1
3	G-1159-103506	SCREW, ROUND HEAD CRS REC, 10 – 32	2
4	G-1250-1030N	FLATWASHER, 10 NARROW	2
5	EC-1170-06*96.0	CABLE, ELECTRICAL	1
6	EC-1178-02	LOCKNUT, CONDUIT	1
7	EC-1175-06-A	CONNECTOR, POWER CABLE	1

9.16.10 Return Sight Gauge (Option U)

Refer to Section 10.6 Hydraulic Hoses concerning hose inspection. Annual calibration of instrumentation is recommended.

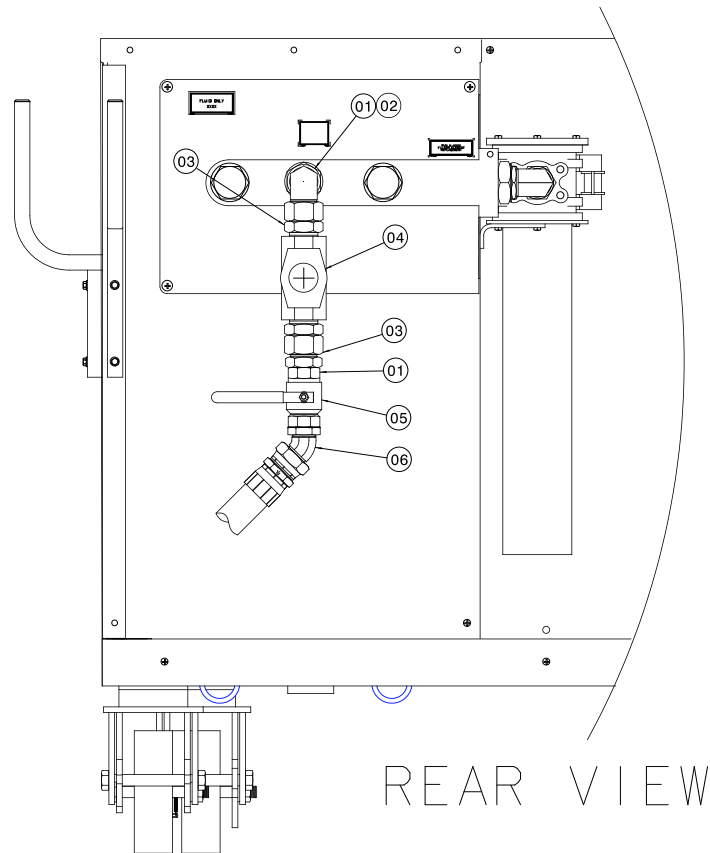

Model Number	Fluid Type
5711	MIL-PRF-5606
5721	MIL-PRF-83282
5731	Aviation Phosphate Ester, Skydrol
5751	Aviation Phosphate Ester, HyJet

Item	5711 & 5721	5731 & 5751	Description	Qty
	Part Number	Part Number		
1	N-2007-31-S-B	N-2007-31-S-E	CONNECTOR, STRAIGHT THREAD	2
2	N-2002-12-S	N-2002-12-S	ELBOW, SWIVEL NUT	1
3	N-2030-15-S	N-2030-15-S	SWIVEL, FEMALE, 24 X 1 ½ NPT	2
4	HC-2232-01	HC-2235	SIGHTGAUGE, FLOW 1 ½	1
5	HC-2266-24	HC-3042-24	VALVE, BALL	Ref
6	N-2042-14-S-B	N-2042-14-S-E	ELBOW, 45° STRAIGHT THREAD	1

9.16.11 Split System Return Sight Gauge (Option Y)

Refer to Section 10.6 Hydraulic Hoses concerning hose inspection. Annual calibration of instrumentation is recommended.

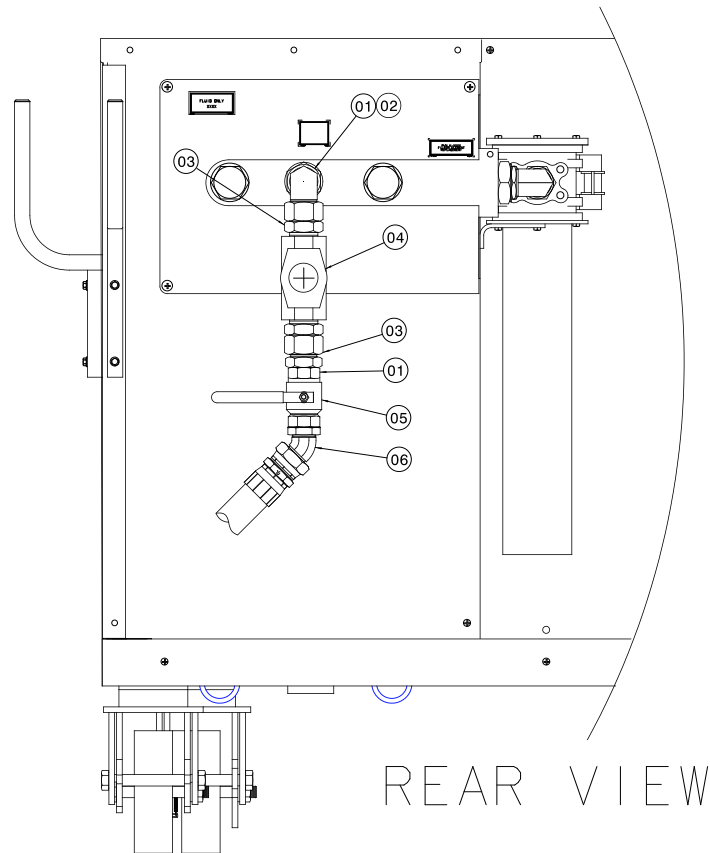

Model Number	Fluid Type
5711	MIL-PRF-5606
5721	MIL-PRF-83282
5731	Aviation Phosphate Ester, Skydrol
5751	Aviation Phosphate Ester, HyJet

Item	5711 & 5721	5731 & 5751	Description	Qty
	Part Number	Part Number		
1	N-2007-31-S-B	N-2007-31-S-E	CONNECTOR, STRAIGHT THREAD	4
2	N-2002-12-S	N-2002-12-S	ELBOW, SWIVEL NUT	2
3	N-2030-15-S	N-2030-15-S	SWIVEL, FEMALE, 24 X 1 ½ NPT	4
4	HC-2232-01	HC-2235	SIGHT GAUGE, FLOW 1 ½	2
5	HC-2266-24	HC-3042-24	VALVE, BALL	Ref
6	N-2042-14-S-B	N-2042-14-S-E	ELBOW, 45° STRAIGHT THREAD	2

9.16.12 Return Backpressure (Option V)

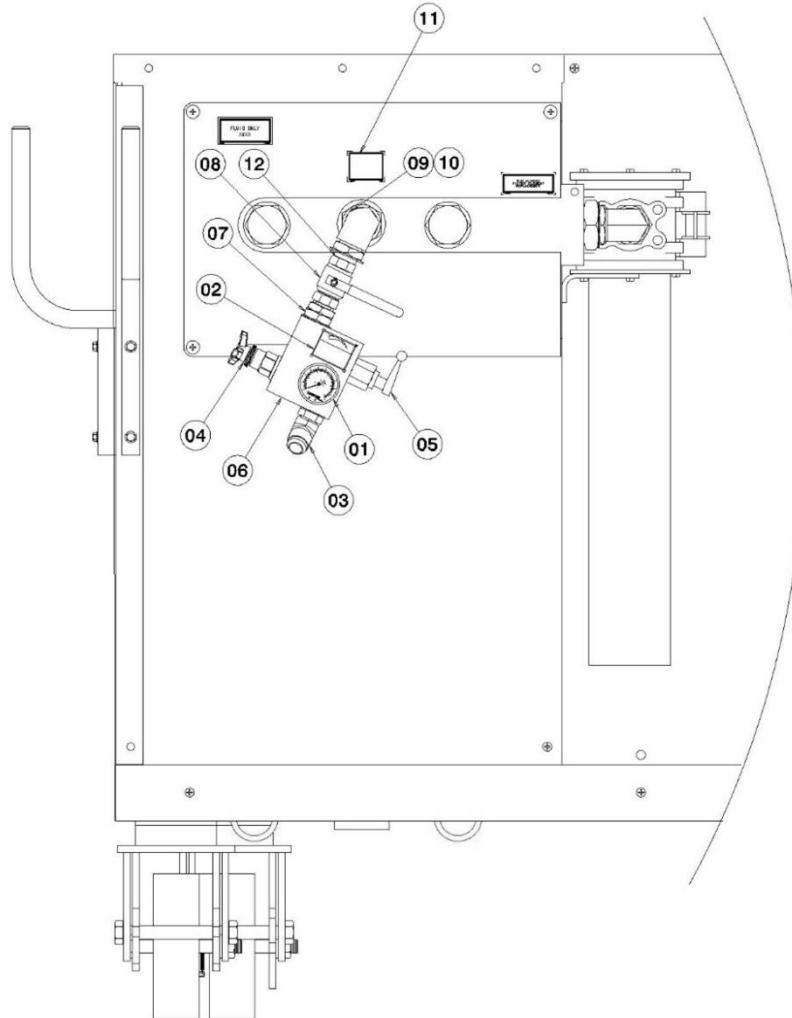

Model Number	Fluid Type
5711	MIL-PRF-5606
5721	MIL-PRF-83282
5731	Aviation Phosphate Ester, Skydrol
5751	Aviation Phosphate Ester, HyJet

Item	5711 & 5721	5731 & 5751	Description	Qty
	Part Number	Part Number		
1	HC-2260	HC-2260	GAUGE, PRESSURE 0-300 PSI	1
2	V-2062	V-2062	LABEL, BACK PRESSURE VALVE	1
3	N-2042-14-S-B	N-2042-14-S-E	ELBOW, 45 DEG STR THD	1
4	HC-2663	HC-2656	VALVE, BACKPRESSURE	1
5	HC-1433	HC-1517	VALVE, BYPASS	1
6	HC-2662	HC-2662	MANIFOLD, BACKPRESSURE	1
7	N-2464-12-S-B	N-2464-12-S-E	UNION, STR THD	1
8	HC-2266-24	HC-3042-24	VALVE, BALL	REF
9	N-2002-12-S	N-2002-12-S	ELBOW, 90 DEG SWIVEL	1
10	N-2007-31-S-B	N-2007-31-S-E	CONNECTOR, STR THD	1
11	V-2061	V-2061	LABEL, BACKPRESSURE BYPASS VALVE	1
12	N-2036-13-S-B	N-2036-13-S-E	SWIVEL, 37 DEG FEMALE	1
13	S-3472-00	S-3472-00	BRACKET, MANIFOLD (NOT SHOWN)	1

9.16.13 Drip Pan (Option 4)

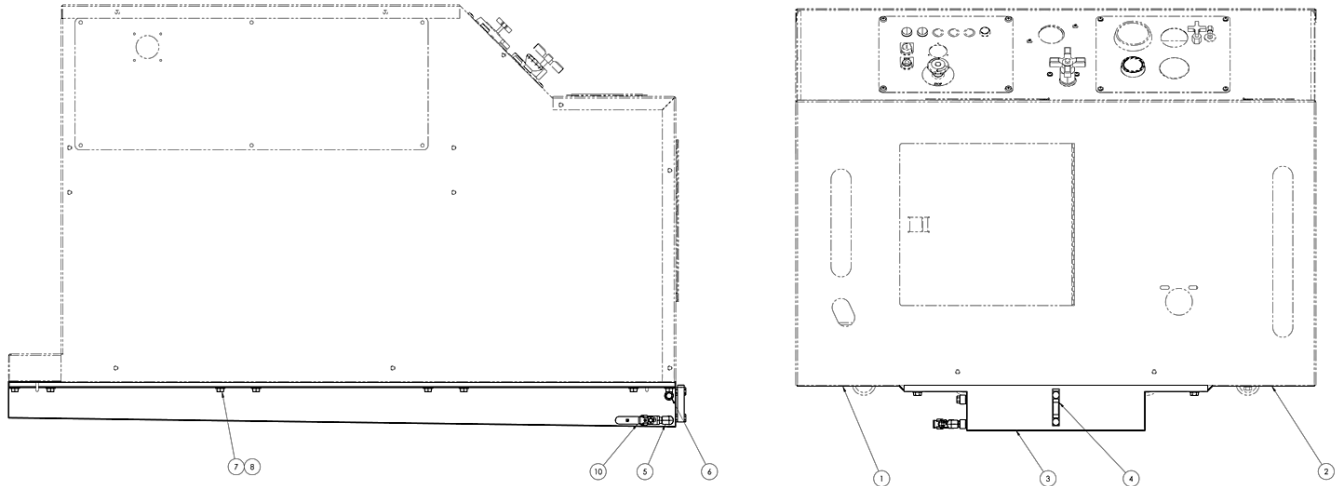

Model Number	Fluid Type
5711	MIL-PRF-5606
5721	MIL-PRF-83282
5731	Aviation Phosphate Ester, Skydrol
5751	Aviation Phosphate Ester, HyJet

	5711 & 5721	5731 & 5751		
Item	Part Number	Part Number	Description	Qty
1	S-2358	S-2358	PAN, LEFT SIDE DRIP	1
2	S-2359	S-2359	PAN, RIGHT SIDE DRIP	1
3	S-2360	S-2360	PAN, CENTER DRIP	1
4	HC-1382-03	HC-1383-03	GAUGE, SIGHT	1
5	N-2661-02-S-B	N-2661-02-S-E	ELBOW, STRAIGHT THREAD	1
6	N-2053-05-S-B	N-2053-05-S-E	PLUG, STRAIGHT THREAD	1
7	G-1100-109510	G-1100-109510	BOLT, HEX HEAD, 1/2 - 20 X 1/2 LONG	16
8	G-1250-1090N	G-1250-1090N	FLATWASHER, 1/2 NARROW	16
9	G-1100-109514	G-1100-109514	BOLT, HEX HEAD, 1/2 - 20 X 1 1/2 LONG	16
10	HC-3075-06-B	HC-3075-06-E	VALVE, BALL LOCK 600PSI BRASS ORB	1

9.16.14 Contamination Monitor

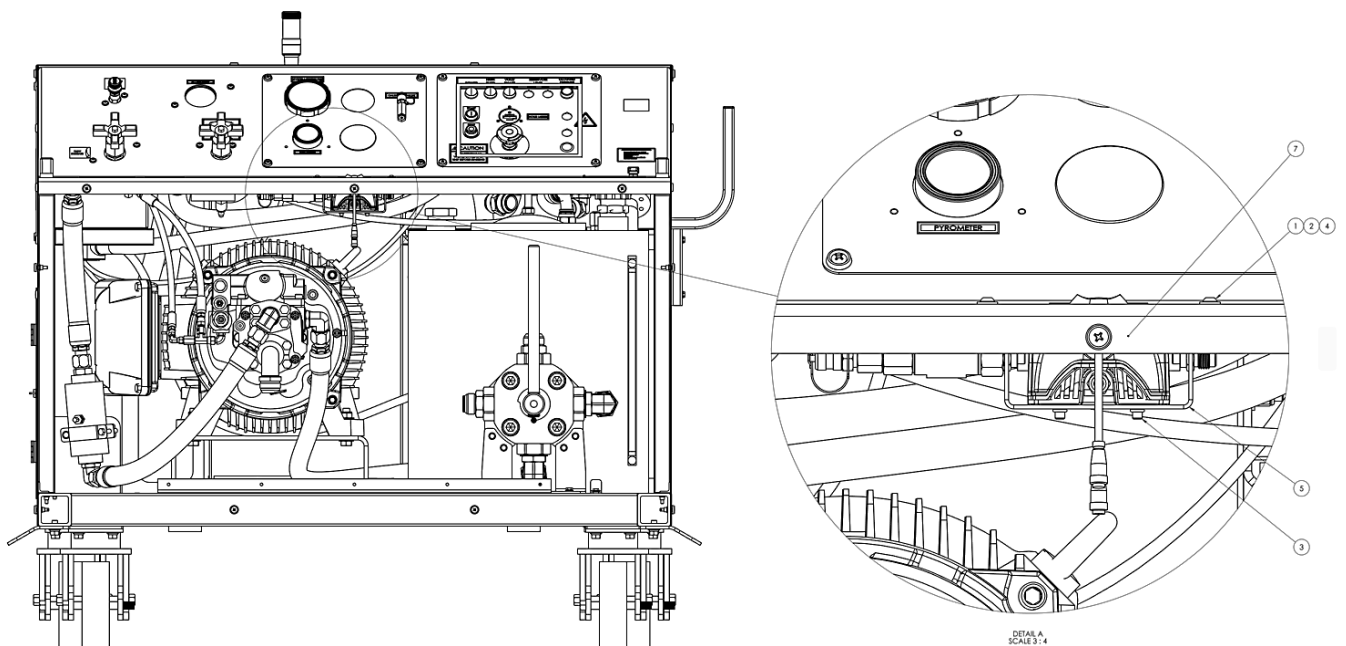
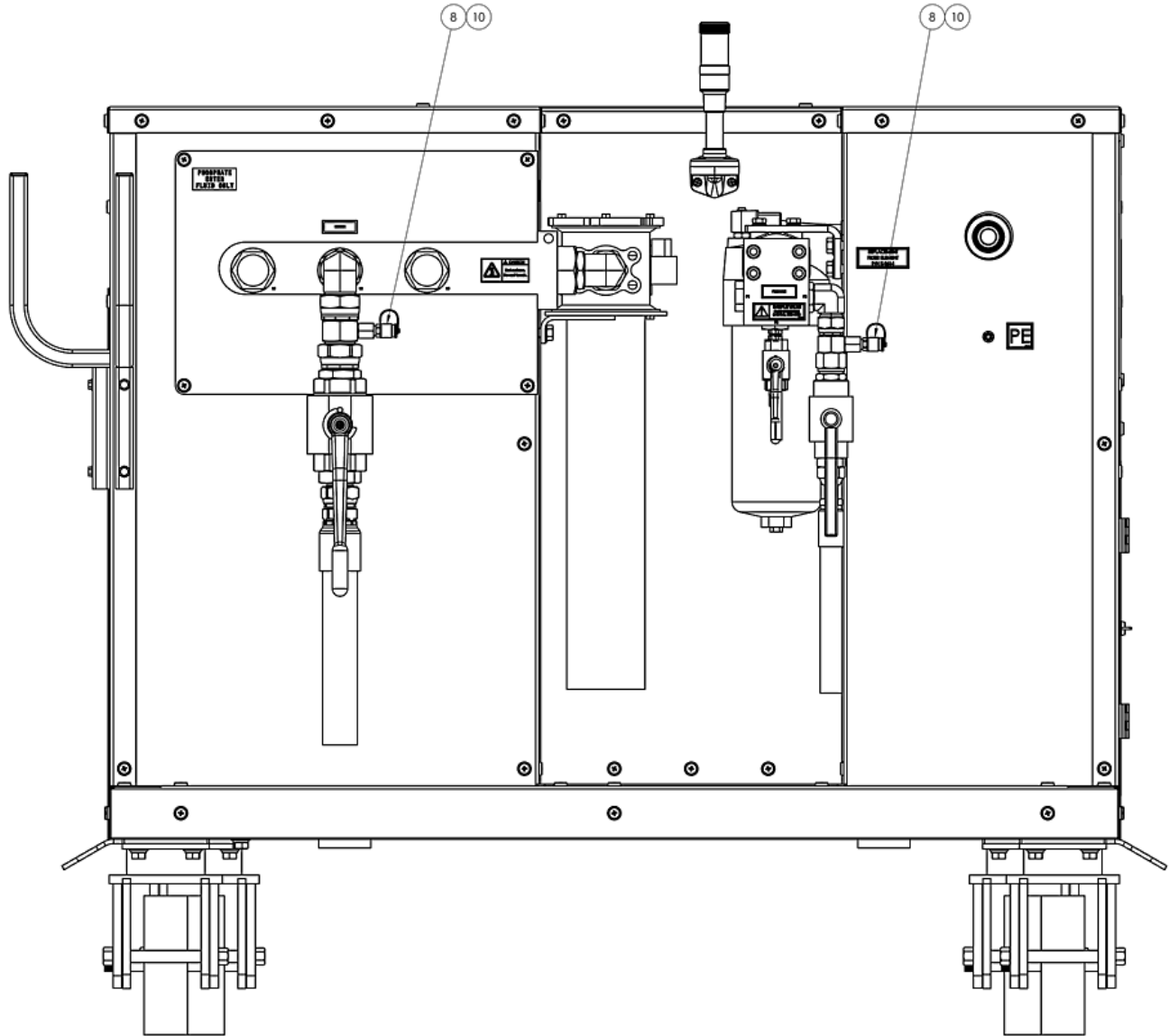

9.16.14 Contamination Monitor (continued)

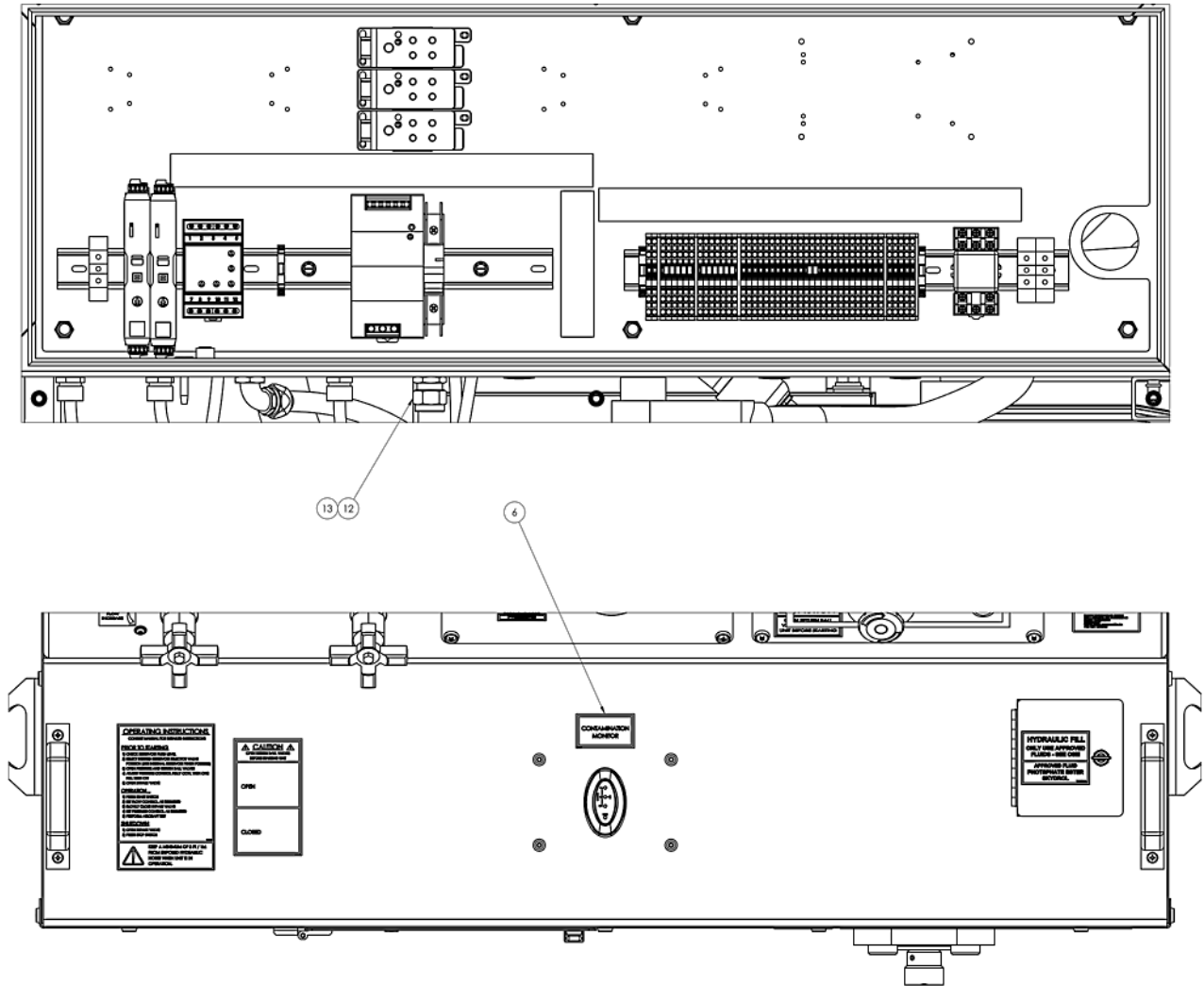

Model Number	Fluid Type
5711	MIL-PRF-5606
5721	MIL-PRF-83282
5731	Aviation Phosphate Ester, Skydrol
5751	Aviation Phosphate Ester, HyJet

Item	5711 & 5721	5731 & 5751	Description	Qty
	Part Number	Part Number		
1	G-1154-105206	G-1154-105206	SCREW, 1/4-20 X 3/4" LG. SOC BUTT. HD CAP	4
2	G-1250-1050N	G-1250-1050N	FLATWASHER, 1/4 NARROW	4
3	G-1439-1035-S	G-1439-1035-S	NUTSERT, THIN WALL #10-32	2
4	G-1439-1050-S	G-1439-1050-S	NUTSERT, THIN WALL 1/4-20	4
5	S-2842-00	S-2842-00	PLATE, ICOUNT SUPPORT	1
6	V-2653	V-2653	LABEL, CONTAMINATION MONITOR	1
7	Z-11249-01	Z-11249-02	ASSEMBLY, CONT. MONITOR	1
8	N-2544-02	N-2734	CPLG, QUICK DISCONNECT	2
9	TF-1085-01-120	TF-1111-03	ASSEMBLY, HOSE #4	2
10	N-3037	---	REDUCER, BSPP	2
11	EC-2956	EC-2956	CABLE, ICOUNT (NOT SHOWN)	1
12	EC-1175-05-A	EC-1175-08-A	CONNECTOR, POWER CABLE	1
13	EC-1176-02	EC-1176-02	LOCKNUT, CONDUIT	1

9.17 REPLACEMENT LABELS PARTS LISTS

9.17.1 Base Unit

Parts List
All Fluid Types

Part Number	Description	Qty
V-1001	"Made in USA"	1
V-1033	"TRONAIR"	1
V-1050	ISO Electrical Shock Symbol	2
V-1365	"SYSTEM PRESSURE"	1
V-1366	"HPU BY-PASS VALVE"	1
V-1374	"ROTATION"	1
V-1470	"CAUTION..."	1
V-1882	Control Panel Lights	1
V-1883	"HOUR METER"	1
V-1884	"FLOWMETER"	1
V-1886	"PYROMETER"	1
V-1888	"SHUT-OFF/CALIBRATION PORT"	1
V-1893	"SAMPLE VALVE"	1
V-1894	"PRESSURE"	1
V-1895	"RETURN"	1
V-1896	"MAXIMUM OIL LEVEL"	1
V-1897	"MINIMUM OIL LEVEL"	1
V-1898	"PRESSURE and FLOW CONTROLS INSIDE"	1
V-1900	"WARNING KEEP 5 FT CLEAR..."	2
V-1914	Reservoir Selector Valve	1
V-1918	"PE"	1
V-1919	"OPERATING INSTRUCTIONS..."	1
V-2008	"FLOW INCREASE"	1
V-2009	"PRESSURE INCREASE"	1

9.17.2 Fluid Labels

Model 5711 Parts List

Fluid Type: MIL-PRF-5606

Part Number	Description	Qty
V-1975	"MIL-PRF-5606"	2

Model 5721 Parts List

Fluid Type: MIL-PRF-83282

Part Number	Description	Qty
V-1976	"MIL-PRF-83282"	2

Model 5731 & 5751 Parts List

Fluid Type: Aviation Phosphate Ester, Type IV and V

Part Number	Description	Qty
V-1977	"PHOSPHATE ESTER FLUIDS ONLY"	2

9.17.3 Filter Element Kit Labels

Model 5711 & 5721 Parts List
Fluid Type: MIL-PRF-5606 & MIL-PRF-83282

Part Number	Description	Qty
V-1959	"REPLACEMENT FILTER ELEMENT K-3613"	1
V-1961	"REPLACEMENT FILTER ELEMENT K-3615"	1
V-1916	"REPLACEMENT DESICCANT FILTER ELEMENT HC-1763"	1

Model 5731 & 5751 Parts List
Fluid Type: Aviation Phosphate Ester, Type IV and V

Part Number	Description	Qty
V-1960	"REPLACEMENT FILTER ELEMENT K-3614"	1
V-1962	"REPLACEMENT FILTER ELEMENT K-3616"	1
V-1916	"REPLACEMENT DESICCANT FILTER ELEMENT HC-1763"	1

9.17.4 Split System (Option C)

Parts List
All Fluid Types

Part Number	Description	Qty
V-2004	"SYSTEM 1 PRESSURE"	1
V-2005	"SYSTEM 2 PRESSURE"	1
V-2006	"SYSTEM 1 RETURN"	1
V-2007	"SYSTEM 2 RETURN"	1

9.17.5 Hand Pump (Option M) Labels

Model 5711 & 5721 Parts List
Fluid Type: MIL-PRF-5606 & MIL-PRF-83282

Part Number	Description	Qty
V-1887	"HAND PUMP PRESSURE"	1
V-1915	"HAND PUMP"	1
V-1988	"REPLACEMENT FILTER ELEMENT K-3751"	1

Model 5731 & 5751 Parts List
Fluid Type: Aviation Phosphate Ester, Type IV and V

Part Number	Description	Qty
V-1887	"HAND PUMP PRESSURE"	1
V-1915	"HAND PUMP"	1
V-1989	"REPLACEMENT FILTER ELEMENT K-3752"	1

10.0 PROVISION OF SPARES

10.1 SOURCE OF SPARE PARTS

Spare parts may be obtained from the manufacturer:

TRONAIR, Inc.	Telephone: (419) 866-6301 or 800-426-6301
1 Air Cargo Pkwy East	Fax: (419) 867-0634
Swanton, Ohio 43558 USA	E-mail: sales@tronair.com
	Website: www.tronair.com



For Spare Parts, Operations & Service Manuals or Service Needs:
Scan the QR code or visit Tronair.com/aftermarket

10.2 RECOMMENDED SPARE PARTS LISTS

It is recommended that the following spare parts be kept on hand and available for immediate use during maintenance.

Model Number	Fluid Type
5711	MIL-PRF-5606
5721	MIL-PRF-83282
5731	Aviation Phosphate Ester, Skydrol, Type IV and V
5751	Aviation Phosphate Ester, HyJet, Type V

5711 & 5721		5731 & 5751	
Part Number	Part Number	Description	Qty
TF-1038-28*300	TF-1040-05*300	HOSE, SUPPLY (EXTERNAL)	1 to 4
TF-1039-12*300	TF-1041-04*300	HOSE, RETURN (EXTERNAL)	1 to 4
HC-1763	HC-1763	DESICCANT FILTER ELEMENT	1
K-3613	K-3614	KIT, PRESSURE FILTER ELEMENT	1
K-3615	K-3616	KIT, RETURN FILTER ELEMENT	1
K-3751	K-3752	KIT, HAND PUMP FILTER ELEMENT (OPTIONAL)	1
EC-1542-03	EC-1542-03	FUSE, LP-CC 0.8A (575V ONLY)	2

11.0 CALIBRATION OF INSTRUMENTATION

All gauges on the Hydraulic Power Unit can be either returned to Tronair for calibration or certified by the end user if proper calibration equipment is available. Gauges returned to Tronair for calibration will be tested with standards traceable to N.I.S.T. (National Institute of Standards and Technology). Tronair recommends calibration of instrumentation at yearly intervals, but actual calibration dates may be based upon frequency of use and the end users quality system. For information on returning gauges for calibration, Reference 12.1 – Source of Calibration.

11.1 SOURCE OF CALIBRATION

TRONAIR , Inc.	Telephone: (419) 866-6301 or 800-426-6301
1 Air Cargo Pkwy East	Fax: (419) 867-0634
Swanton, Ohio 43558 USA	E-mail: sales@tronair.com
	Website: www.tronair.com

12.0 IN SERVICE SUPPORT

Contact Tronair, Inc. for technical services and information. See Section 1.3 – Manufacturer.

13.0 GUARANTEES/LIMITATION OF LIABILITY

Tronair products are warranted to be free of manufacturing or material defects for a period of one year after shipment to the original customer. This is solely limited to the repair or replacement of defective components. This warranty does not cover the following items:

- a) Parts required for normal maintenance
- b) Parts covered by a component manufacturers warranty
- c) Replacement parts have a 90-day warranty from date of shipment

If you have a problem that may require service, contact Tronair immediately. Do not attempt to repair or disassemble a product without first contacting Tronair, any action may affect warranty coverage. When you contact Tronair be prepared to provide the following information:

- a) Product Model Number
- b) Product Serial Number
- c) Description of the problem

If warranty coverage is approved, either replacement parts will be sent or the product will have to be returned to Tronair for repairs. If the product is to be returned, a Return Material Authorization (RMA) number will be issued for reference purposes on any shipping documents. Failure to obtain a RMA in advance of returning an item will result in a service fee. A decision on the extent of warranty coverage on returned products is reserved pending inspection at Tronair. Any shipments to Tronair must be shipped freight prepaid. Freight costs on shipments to customers will be paid by Tronair on any warranty claims only. Any unauthorized modification of the Tronair products or use of the Tronair products in violation of cautions and warnings in any manual (including updates) or safety bulletins published or delivered by Tronair will immediately void any warranty, express or implied.

The obligations of Tronair expressly stated herein are in lieu of all other warranties or conditions expressed or implied. **Any unauthorized modification of the Tronair products or use of the Tronair products in violations of cautions and warnings in any manual (including updates) or safety bulletins published or delivered by Tronair will immediately void any warranty, express or implied and Tronair disclaims any and all liability for injury (WITHOUT LIMITATION and including DEATH), loss or damage arising from or relating to such misuse.**

14.0 APPENDICES

APPENDIX I	Declaration of Conformity
APPENDIX II	Hydraulic Schematic (INS-2370)
APPENDIX III	Electrical Schematic (INS-2942 & INS-2969 (575V))
APPENDIX IV	Wiring Diagram (INS-2947)
APPENDIX V	Oilgear Pump Manual
APPENDIX VI	Safety Data Sheet pertaining to MIL-PRF-5606 Hydraulic Fluid
APPENDIX VII	Safety Data Sheet pertaining to MIL-PRF-83282 Hydraulic Fluid
APPENDIX VIII	Safety Data Sheet pertaining to Skydrol Hydraulic Fluid
APPENDIX IX	Safety Data Sheet pertaining to HyJet
APPENDIX X	Instrument Certification Notice



APPENDIX I

Declaration of Conformity

Model Number(s) 5711, 5721, 5731, 5751
Product Type/Name: Hydraulic Power Unit

Declaration: Tronair has assessed the equipment described above against the Essential Health and Safety Requirements of one or more Directives. Based on this assessment, the equipment described above is deemed to comply with the directive(s) listed below.

This declaration of conformity is issued under the sole responsibility of the manufacturer.

Directives: 2006/42/EC – European machinery directive

2014/30/EU – Electromagnetic compatibility

Standards:

EN ISO 12100:2010

Safety of machinery – General principles for design – Risk assessment and risk reduction

EN 982:1996+A1:2008

Safety of machinery – Safety requirements for fluid power systems and their components - Hydraulics

EN 1915-1:2023

Aircraft ground support equipment – General requirements – Part 1: basic safety requirements

EN 1915-2:2001+A1:2009

Aircraft ground support equipment – General requirements – Part 2: stability and strength requirements, calculations and test methods

EN 60204-1:2018

Safety of machinery – Electrical equipment of machines – General requirements

EN 61000-6-2:2005/AC:2005

Electromagnetic compatibility (EMC) – Part 6-2: Generic standards – Immunity for industrial environments

EN 61000-6-4:2007/A1:2011

Electromagnetic compatibility (EMC) – Part 6-4: Generic standards – Emission standard industrial environments

IEC 61000-3-11

Electromagnetic compatibility (EMC) – Part 3-11: Limits – Limitation of voltage changes, voltage fluctuations and flicker in public low-voltage supply systems – Equipment with rated current ≤ 75 A and subject to conditional connection

IEC 61000-3-12

Electromagnetic compatibility (EMC) – Part 3-12: Limits – Limits for harmonic currents produced by equipment connected to public low-voltage systems with input current >16 A and ≤ 75 A per phase

ISO 3744:2010

Acoustics — Determination of sound power levels and sound energy levels of noise sources using sound pressure — Engineering methods for an essentially free field over a reflecting plane

ISO 4413:2010 (E)

Hydraulic fluid power – General rules and safety requirements for systems and their components

Markings: 

Location of Issue: Tronair, 1 Air Cargo Parkway East, Swanton, OH 43558

Identification of person empowered to sign on behalf of the Manufacturer: Quality Assurance Representative



APPENDIX II

Hydraulic Schematic (INS-2370)

THIS DRAWING IS THE PROPERTY OF TRONAIR, INC. IT IS FURNISHED TO YOU FOR CONFIDENTIAL INFORMATION PURPOSES ONLY AND IS NOT TO BE DISCLOSED TO ANYONE ELSE OR REPRODUCED OR USED FOR MANUFACTURING PURPOSES WITHOUT THE EXPRESS WRITTEN PERMISSION OF TRONAIR, INC.

LET	REVISION	ECN	DWN	CHK	DATE
A	ORIGINAL RELEASE	20309	-	-	01-30-17

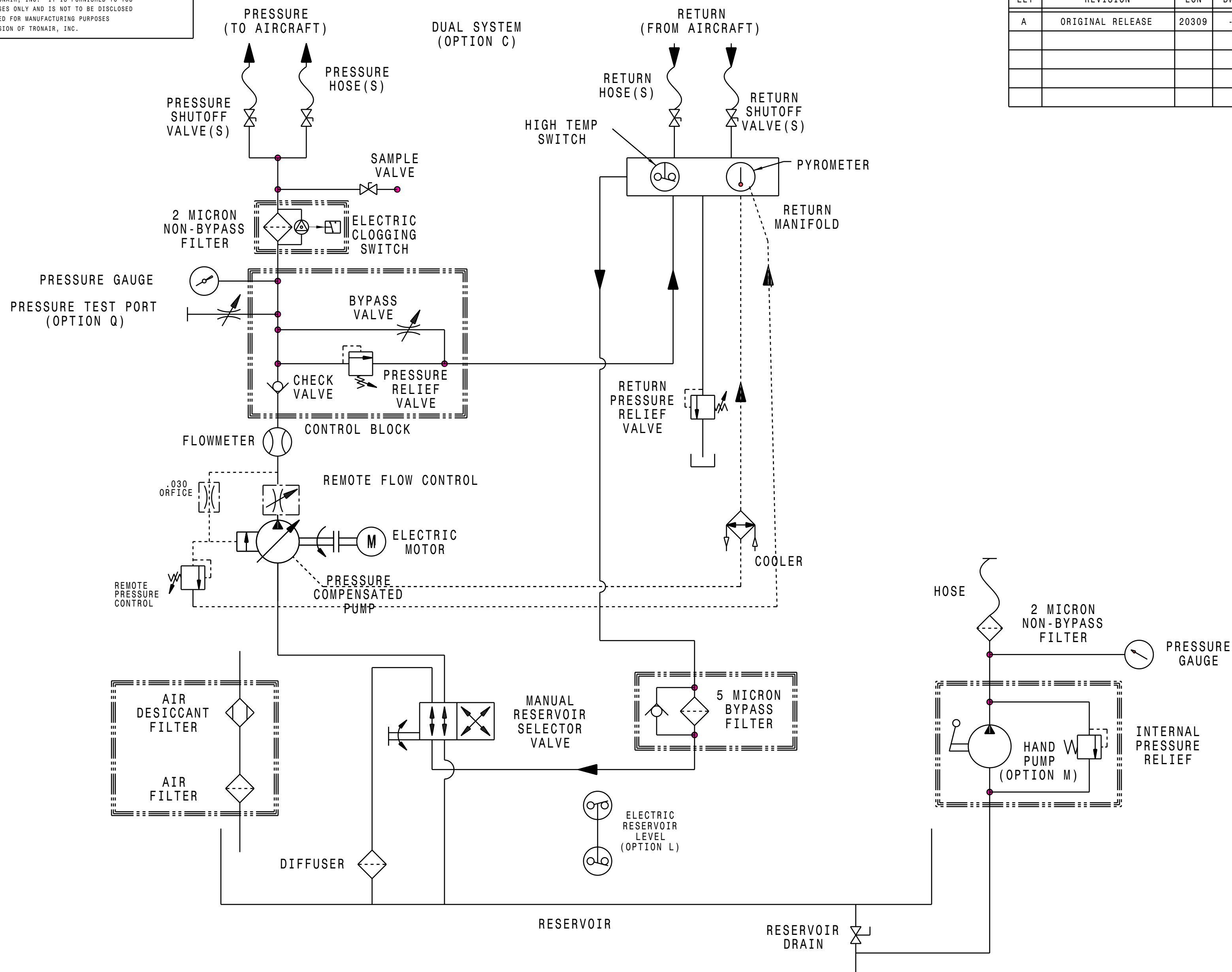

MAKE FROM:	N / A
MATERIAL:	N / A
FINISH:	N / A
REFERENCE:	N / A
SCALE:	FULL
TYPE:	N / A
SIZE:	C
DO NOT SCALE DRAWING	

BREAK ALL SHARP EDGES AND CORNERS
TOLERANCES UNLESS OTHERWISE SPECIFIED

DECIMAL	.X	± .100
	.XX	± .030
	.XXX	± .010
FRACTION	X/XX	± 1/16

ANGLES: ± 1/2 DEGREE
< > INDICATES CRITICAL DIMENSIONS
() INDICATES REFERENCE DIMENSIONS

TRONAIR AIRCRAFT GROUND SUPPORT EQUIPMENT

DWN BY CDG CKD BY PEH 01-31-17

SCHEMATIC, HYDRAULIC

05	INS-2370	REV A
----	----------	-------



APPENDIX III

Electrical Schematic (INS-2942 & INS-2969 (575V))

DRAWING LIST

SHEET #	SHEET DESCRIPTION
00	DRAWING LIST
01	SCHEMATIC - MOTOR & HIGH VOLTAGE WIRING, GROUNDING
02	SCHEMATIC - INSTRUMENTATION & OPERATOR CONTROLS
03	SCHEMATIC - INSTRUMENTATION & OPERATOR CONTROLS (CONTINUED)
04	TERMINAL STRIP 1 LAYOUT
05	TERMINAL STRIP 1 LAYOUT (CONTINUED)
06	WIRE SCHEDULE
07	CABLE SCHEDULE
08	SYMBOLGY LEGEND
09	REVISION HISTORY

 <small>AIRCRAFT GROUND SUPPORT EQUIPMENT</small>	<small>DWN BY</small> NGL	<small>CKD BY</small> PEH	<small>DATE</small> 7/25/2025
	SCHEMATIC, ELECTRICAL		
	INS-2942	<small>SHEET</small> 00 OF 09	<small>REV</small> C

THIS DRAWING IS THE PROPERTY OF TRONAIR, INC. IT IS FURNISHED TO YOU FOR CONFIDENTIAL INFORMATION PURPOSES ONLY AND IS NOT TO BE DISCLOSED TO ANYONE OR REPRODUCED OR USED FOR MANUFACTURING PURPOSES WITHOUT THE EXPRESS WRITTEN PERMISSION OF TRONAIR, INC.

01 40HP: 60HZ (208V, 230V, 380V, 460V) / 50HZ (200V, 220V, 380V, 415V, 440V)
 75HP: 60HZ (380V, 460V) / 50HZ (380V, 415V, 440V)

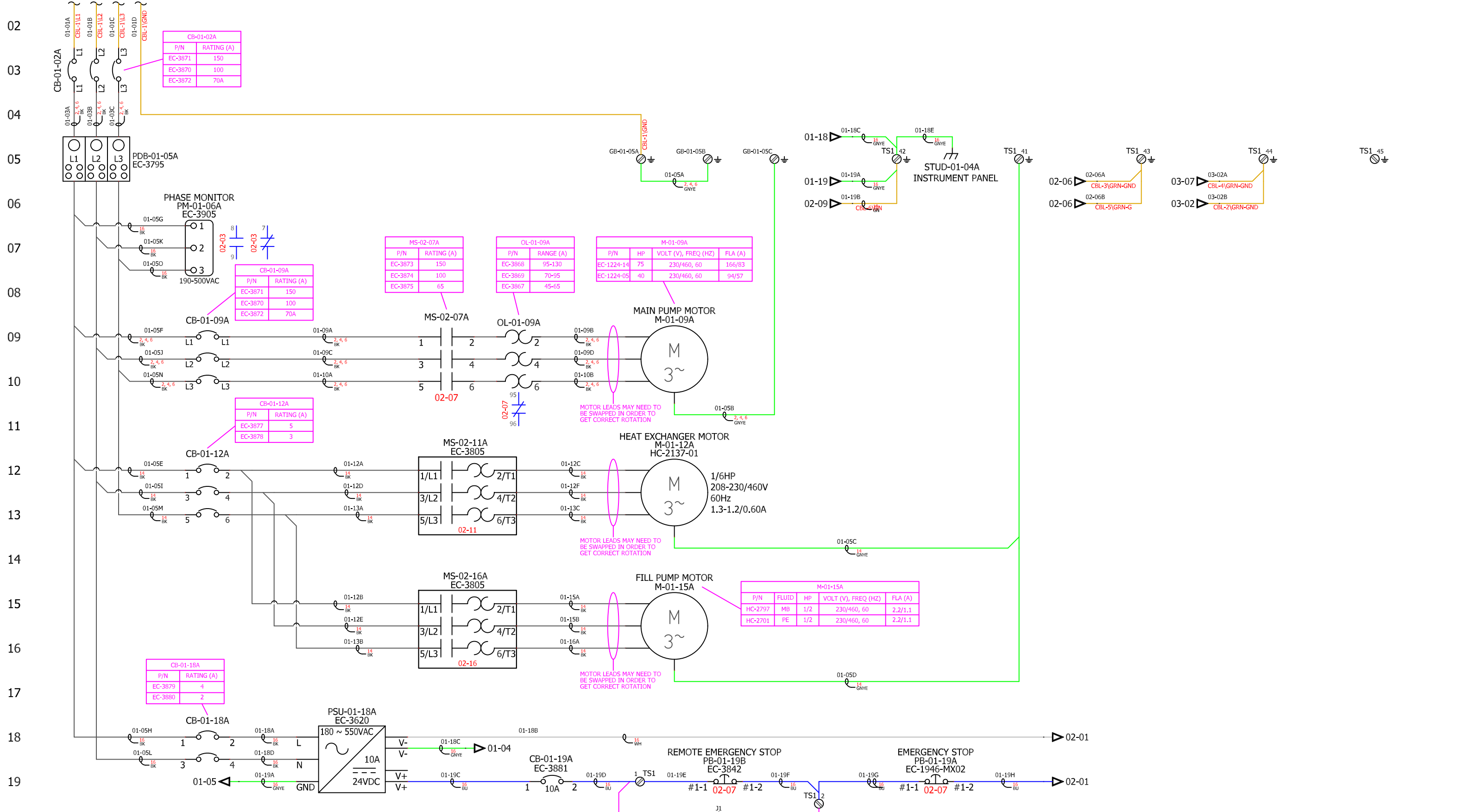

P/N	RATING (A)
EC-3871	150
EC-3870	100
EC-3872	70A

P/N	RATING (A)
EC-3871	150
EC-3870	100
EC-3872	70A

P/N	RATING (A)
EC-3877	5
EC-3878	3

P/N	RATING (A)
EC-3879	4
EC-3880	2

P/N	RATING (A)
EC-3873	150
EC-3874	100
EC-3875	65

P/N	RANGE (A)
EC-3868	95-130
EC-3869	70-95
EC-3867	45-65

P/N	HP	VOLT (V), FREQ (HZ)	FLA (A)
EC-1224-14	75	230/460, 60	166/83
EC-3869	40	230/460, 60	94/57

P/N	FLUID	HP	VOLT (V), FREQ (HZ)	FLA (A)
HC-2797	MB	1/2	230/460, 60	2.2/1.1
HC-2701	PE	1/2	230/460, 60	2.2/1.1



AIRCRAFT GROUND SUPPORT EQUIPMENT

DWN BY NGL CKD BY PEH DATE 7/25/2025

THIS DRAWING IS THE PROPERTY OF TRONAIR, INC. IT IS FURNISHED TO YOU FOR CONFIDENTIAL INFORMATION PURPOSES ONLY AND IS NOT TO BE DISCLOSED TO ANYONE OR REPRODUCED OR USED FOR MANUFACTURING PURPOSES WITHOUT THE EXPRESS WRITTEN PERMISSION OF TRONAIR, INC.

SCHEMATIC, ELECTRICAL

INS-2942 SHEET 01 OF 09 REV C

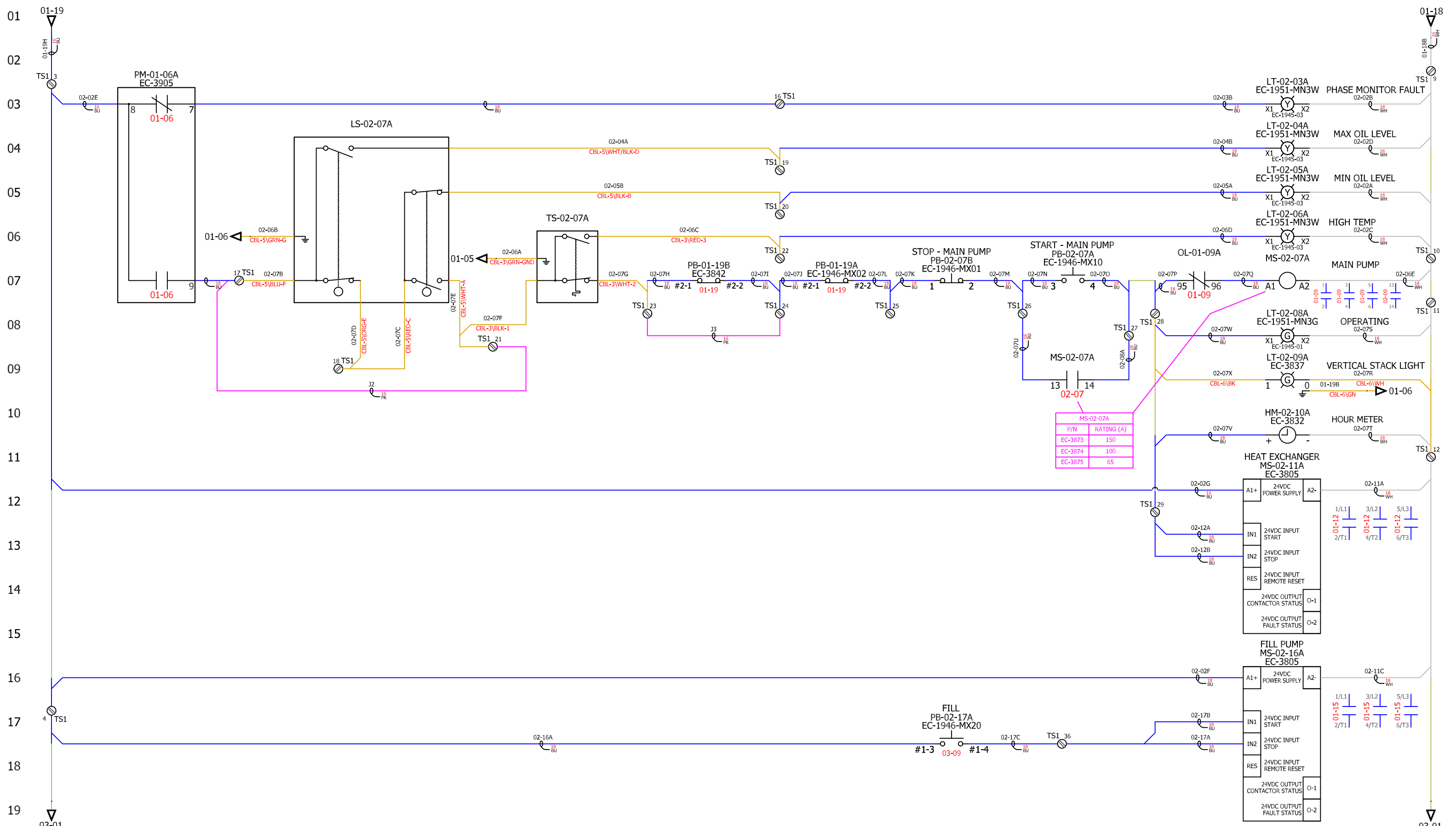

MS-02-07A	
P/N	RATING (A)
EC-3873	150
EC-3874	100
EC-3875	65

<p>AIRCRAFT GROUND SUPPORT EQUIPMENT</p> <p>THIS DRAWING IS THE PROPERTY OF TRONAIR, INC. IT IS FURNISHED TO YOU FOR CONFIDENTIAL INFORMATION PURPOSES ONLY AND IS NOT TO BE DISCLOSED TO ANYONE OR REPRODUCED OR USED FOR MANUFACTURING PURPOSES WITHOUT THE EXPRESS WRITTEN PERMISSION OF TRONAIR, INC.</p>	DWN BY	NGL	CKD BY	PEH	DATE	7/25/2025
	SCHEMATIC, ELECTRICAL					
	INS-2942			SHEET	02 OF 09	REV

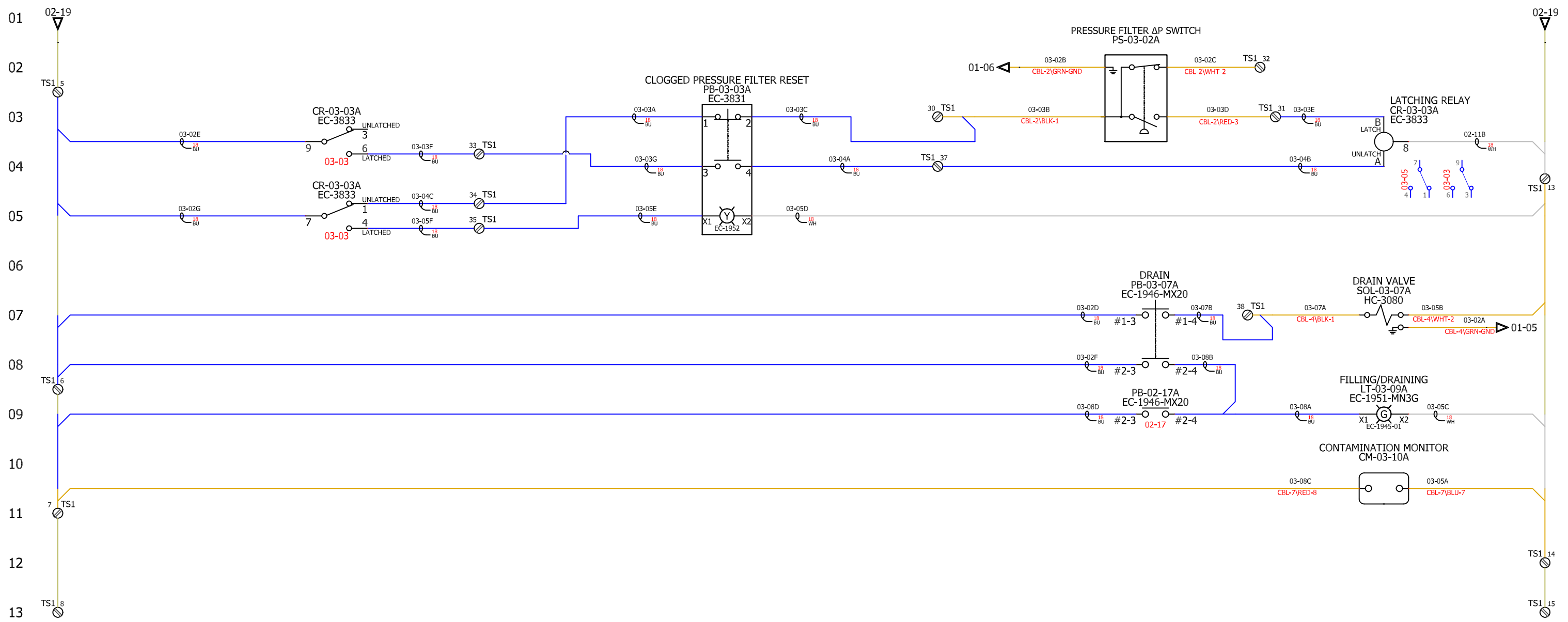

	AIRCRAFT GROUND SUPPORT EQUIPMENT		DWN BY	NGL	CKD BY	PEH	DATE	7/25/2025	
	SCHEMATIC, ELECTRICAL								
	THIS DRAWING IS THE PROPERTY OF TRONAIR, INC. IT IS FURNISHED TO YOU FOR CONFIDENTIAL INFORMATION PURPOSES ONLY AND IS NOT TO BE DISCLOSED TO ANYONE OR REPRODUCED OR USED FOR MANUFACTURING PURPOSES WITHOUT THE EXPRESS WRITTEN PERMISSION OF TRONAIR, INC.						SHEET	03 OF 09	REV
INS-2942									

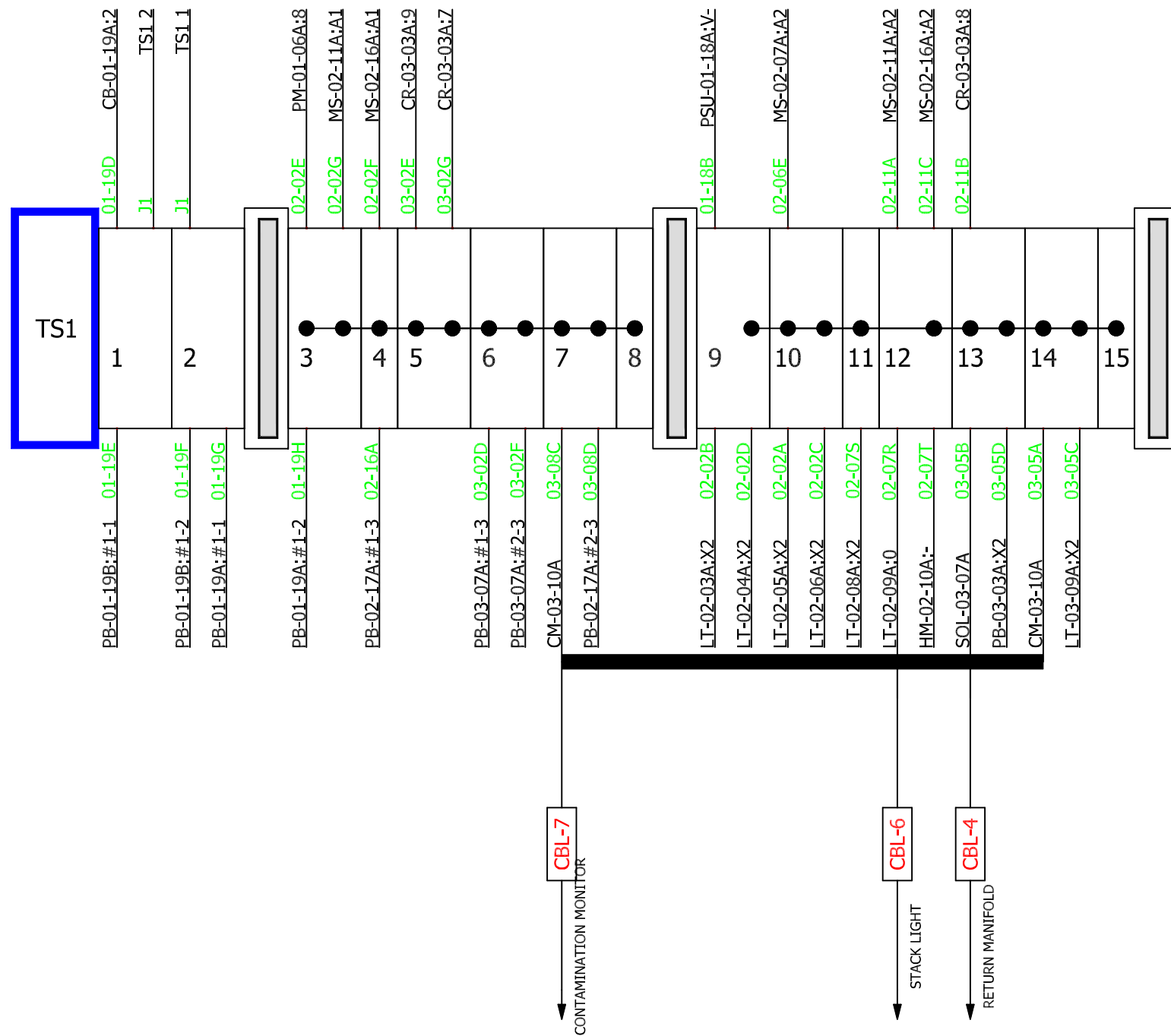

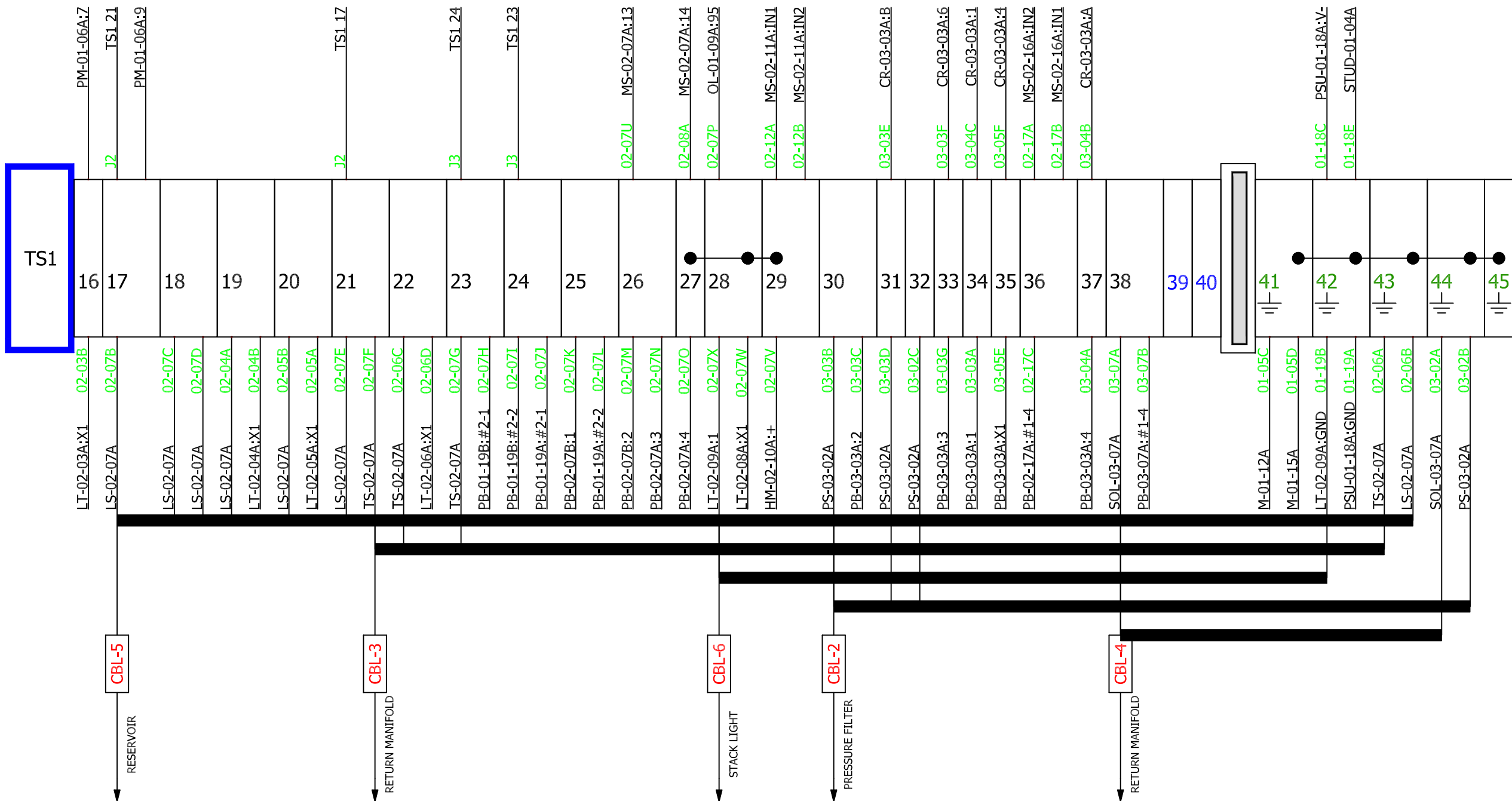

WIRE SCHEDULE

	Label	From	From Pin	To	To Pin	Section	Color	AC/DC
1	01-03A	CB-01-02A	L1	PDB-01-05A	L1	2, 4, 6 AWG	BK	AC
2	01-03B	CB-01-02A	L2	PDB-01-05A	L2	2, 4, 6 AWG	BK	AC
3	01-03C	CB-01-02A	L3	PDB-01-05A	L3	2, 4, 6 AWG	BK	AC
4	01-09A	CB-01-09A	L1	MS-02-07A	1	2, 4, 6 AWG	BK	AC
5	01-09C	CB-01-09A	L2	MS-02-07A	3	2, 4, 6 AWG	BK	AC
6	01-10A	CB-01-09A	L3	MS-02-07A	5	2, 4, 6 AWG	BK	AC
7	01-05F	CB-01-09A	L1	PDB-01-05A	L1	2, 4, 6 AWG	BK	AC
8	01-05J	CB-01-09A	L2	PDB-01-05A	L2	2, 4, 6 AWG	BK	AC
9	01-05N	CB-01-09A	L3	PDB-01-05A	L3	2, 4, 6 AWG	BK	AC
10	01-09B	M-01-09A		OL-01-09A	2	2, 4, 6 AWG	BK	AC
11	01-09D	M-01-09A		OL-01-09A	4	2, 4, 6 AWG	BK	AC
12	01-10B	M-01-09A		OL-01-09A	6	2, 4, 6 AWG	BK	AC
13	01-05A	GB-01-05A		GB-01-05B		2, 4, 6 AWG	GNYE	GND
14	01-05B	GB-01-05C		M-01-09A		2, 4, 6 AWG	GNYE	GND
15	01-12A	CB-01-12A	2	MS-02-11A	1/L1	14 AWG	BK	AC
16	01-12D	CB-01-12A	4	MS-02-11A	3/L2	14 AWG	BK	AC
17	01-13A	CB-01-12A	6	MS-02-11A	5/L3	14 AWG	BK	AC
18	01-12B	CB-01-12A	2	MS-02-16A	1/L1	14 AWG	BK	AC
19	01-12E	CB-01-12A	4	MS-02-16A	3/L2	14 AWG	BK	AC
20	01-13B	CB-01-12A	6	MS-02-16A	5/L3	14 AWG	BK	AC
21	01-05E	CB-01-12A	1	PDB-01-05A	L1	14 AWG	BK	AC
22	01-05I	CB-01-12A	3	PDB-01-05A	L2	14 AWG	BK	AC
23	01-05M	CB-01-12A	5	PDB-01-05A	L3	14 AWG	BK	AC
24	01-12C	M-01-12A		MS-02-11A	2/T1	14 AWG	BK	AC
25	01-12F	M-01-12A		MS-02-11A	4/T2	14 AWG	BK	AC
26	01-13C	M-01-12A		MS-02-11A	6/T3	14 AWG	BK	AC
27	01-15A	M-01-15A		MS-02-16A	2/T1	14 AWG	BK	AC
28	01-15B	M-01-15A		MS-02-16A	4/T2	14 AWG	BK	AC
29	01-16A	M-01-15A		MS-02-16A	6/T3	14 AWG	BK	AC
30	01-05C	M-01-12A		TS1 41		14 AWG	GNYE	GND
31	01-05D	M-01-15A		TS1 41		14 AWG	GNYE	GND
32	01-05H	CB-01-18A	1	PDB-01-05A	L1	16 AWG	BK	AC
33	01-05L	CB-01-18A	3	PDB-01-05A	L2	16 AWG	BK	AC
34	01-18A	CB-01-18A	2	PSU-01-18A	L	16 AWG	BK	AC
35	01-18D	CB-01-18A	4	PSU-01-18A	N	16 AWG	BK	AC
36	01-05G	PM-01-06A	1	PDB-01-05A	L1	16 AWG	BK	AC
37	01-05K	PM-01-06A	2	PDB-01-05A	L2	16 AWG	BK	AC
38	01-05O	PM-01-06A	3	PDB-01-05A	L3	16 AWG	BK	AC
39	01-19C	CB-01-19A	1	PSU-01-18A	V+	16 AWG	BU	DC
40	01-19D	CB-01-19A	2	TS1 1		16 AWG	BU	DC
41	01-19E	TS1 1		PB-01-19B	#1-1	16 AWG	BU	DC
42	01-19G	TS1 2		PB-01-19A	#1-1	16 AWG	BU	DC
43	01-19F	TS1 2		PB-01-19B	#1-2	16 AWG	BU	DC
44	02-02G	TS1 3		MS-02-11A	A1	16 AWG	BU	DC
45	01-19H	TS1 3		PB-01-19A	#1-2	16 AWG	BU	DC
46	02-02E	TS1 3		PM-01-06A	8	16 AWG	BU	DC
47	01-18C	PSU-01-18A	V-	TS1 42		16 AWG	GNYE	GND
48	01-19A	PSU-01-18A	GND	TS1 42		16 AWG	GNYE	GND
49	01-18E	STUD-01-04A		TS1 42		16 AWG	GNYE	GND
50	J1	TS1 2		TS1 1		16 AWG	PK	JUMP
51	J2	TS1 21		TS1 17		16 AWG	PK	JUMP
52	J3	TS1 23		TS1 24		16 AWG	PK	JUMP
53	01-18B	PSU-01-18A	V-	TS1 9		16 AWG	WH	DC
54	02-02D	TS1 9		LT-02-04A	X2	16 AWG	WH	DC
55	03-03E	CR-03-03A	B	TS1 31		18 AWG	BU	DC
56	03-03F	CR-03-03A	6	TS1 33		18 AWG	BU	DC
57	03-04C	CR-03-03A	1	TS1 34		18 AWG	BU	DC
58	03-05F	CR-03-03A	4	TS1 35		18 AWG	BU	DC
59	03-04B	CR-03-03A	A	TS1 37		18 AWG	BU	DC
60	02-07V	HM-02-10A	+	TS1 29		18 AWG	BU	DC

	Label	From	From Pin	To	To Pin	Section	Color	AC/DC
61	03-08A	LT-03-09A	X1	PB-02-17A	#2-4	18 AWG	BU	DC
62	02-07Q	MS-02-07A	A1	OL-01-09A	96	18 AWG	BU	DC
63	02-07U	MS-02-07A	13	TS1 26		18 AWG	BU	DC
64	02-08A	MS-02-07A	14	TS1 27		18 AWG	BU	DC
65	02-12A	MS-02-11A	IN1	TS1 29		18 AWG	BU	DC
66	02-02F	MS-02-16A	A1	TS1 4		18 AWG	BU	DC
67	02-17A	MS-02-16A	IN2	TS1 36		18 AWG	BU	DC
68	02-17B	MS-02-16A	IN1	TS1 36		18 AWG	BU	DC
69	02-07P	OL-01-09A	95	TS1 28		18 AWG	BU	DC
70	02-07H	PB-01-19B	#2-1	TS1 23		18 AWG	BU	DC
71	02-07O	PB-02-07A	4	TS1 27		18 AWG	BU	DC
72	02-07M	PB-02-07B	2	TS1 26		18 AWG	BU	DC
73	03-08B	PB-02-17A	#2-4	PB-03-07A	#2-4	18 AWG	BU	DC
74	03-08D	PB-02-17A	#2-3	TS1 7		18 AWG	BU	DC
75	02-17C	PB-02-17A	#1-4	TS1 36		18 AWG	BU	DC
76	03-03G	PB-03-03A	3	TS1 33		18 AWG	BU	DC
77	03-03A	PB-03-03A	1	TS1 34		18 AWG	BU	DC
78	03-05E	PB-03-03A	X1	TS1 35		18 AWG	BU	DC
79	03-04A	PB-03-03A	4	TS1 37		18 AWG	BU	DC
80	03-02D	PB-03-07A	#1-3	TS1 6		18 AWG	BU	DC
81	03-02F	PB-03-07A	#2-3	TS1 6		18 AWG	BU	DC
82		PM-01-06A	7	TS1 16		18 AWG	BU	DC
83		PM-01-06A	9	TS1 17		18 AWG	BU	DC
84	02-16A	TS1 4		PB-02-17A	#1-3	18 AWG	BU	DC
85	03-02E	TS1 5		CR-03-03A	9	18 AWG	BU	DC
86	03-02G	TS1 5		CR-03-03A	7	18 AWG	BU	DC
87	02-03B	TS1 16		LT-02-03A	X1	18 AWG	BU	DC
88	02-04B	TS1 19		LT-02-04A	X1	18 AWG	BU	DC
89	02-05A	TS1 20		LT-02-05A	X1	18 AWG	BU	DC
90	02-06D	TS1 22		LT-02-06A	X1	18 AWG	BU	DC
91	02-07J	TS1 24		PB-01-19A	#2-1	18 AWG	BU	DC
92	02-07I	TS1 24		PB-01-19B	#2-2	18 AWG	BU	DC
93	02-07L	TS1 25		PB-01-19A	#2-2	18 AWG	BU	DC
94	02-07K	TS1 25		PB-02-07B	1	18 AWG	BU	DC
95	02-07N	TS1 26		PB-02-07A	3	18 AWG	BU	DC
96	02-07W	TS1 28		LT-02-08A	X1	18 AWG	BU	DC
97	02-12B	TS1 29		MS-02-11A	IN2	18 AWG	BU	DC
98	03-03C	TS1 30		PB-03-03A	2	18 AWG	BU	DC
99	03-07B	TS1 38		PB-03-07A	#1-4	18 AWG	BU	DC
100	02-11B	CR-03-03A	8	TS1 13		18 AWG	WH	DC
101	02-07T	HM-02-10A	-	TS1 12		18 AWG	WH	DC
102	02-02B	LT-02-03A	X2	TS1 9		18 AWG	WH	DC
103	02-02A	LT-02-05A	X2	TS1 10		18 AWG	WH	DC
104	02-02C	LT-02-06A	X2	TS1 10		18 AWG	WH	DC
105	03-05C	LT-03-09A	X2	TS1 14		18 AWG	WH	DC
106	02-11A	MS-02-11A	A2	TS1 12		18 AWG	WH	DC
107	02-06E	TS1 10		MS-02-07A	A2	18 AWG	WH	DC
108	02-07S	TS1 11		LT-02-08A	X2	18 AWG	WH	DC
109	02-11C	TS1 12		MS-02-16A	A2	18 AWG	WH	DC
110	03-05D	TS1 13		PB-03-03A	X2	18 AWG	WH	DC



AIRCRAFT GROUND SUPPORT EQUIPMENT

DWN BY NGL CKD BY PEH DATE 7/25/2025

THIS DRAWING IS THE PROPERTY OF TRONAIR, INC. IT IS FURNISHED TO YOU FOR CONFIDENTIAL INFORMATION PURPOSES ONLY AND IS NOT TO BE DISCLOSED TO ANYONE OR REPRODUCED OR USED FOR MANUFACTURING PURPOSES WITHOUT THE EXPRESS WRITTEN PERMISSION OF TRONAIR, INC.

SCHEMATIC, ELECTRICAL
INS-2942 SHEET 06 OF 09 REV C

CABLE SCHEDULE

CBL-1: EC-1227-XX*XXXX, INPUT POWER CABLE

Label	Conductor ID	From	To	Section	Color	Length (in)
01-01A	L1	CB-01-02A: L1	INPUT POWER: L1	AWG		0
01-01B	L2	CB-01-02A: L2	INPUT POWER: L2	AWG		0
01-01C	L3	CB-01-02A: L3	INPUT POWER: L3	AWG		0
01-01D	GND	GB-01-05A:	INPUT POWER: GND	AWG	GN	0

CBL-2: EC-2198, PRESSURE FILTER DIN CABLE

Label	Conductor ID	From	To	Section	Color	Length (in)
03-03B	BLK-1	PS-03-02A:	TS1 30:	16 AWG	BK	118.11
03-03D	RED-3	PS-03-02A:	TS1 31:	16 AWG	RD	118.11
03-02C	WHT-2	PS-03-02A:	TS1 32:	16 AWG	WH	118.11
03-02B	GRN-GND	PS-03-02A:	TS1 44:	16 AWG	GN	118.11

CBL-3: EC-2198, TEMPERATURE SWITCH DIN CABLE

Label	Conductor ID	From	To	Section	Color	Length (in)
02-07F	BLK-1	TS-02-07A:	TS1 21:	16 AWG	BK	118.11
02-06C	RED-3	TS-02-07A:	TS1 22:	16 AWG	RD	118.11
02-07G	WHT-2	TS-02-07A:	TS1 23:	16 AWG	WH	118.11
02-06A	GRN-GND	TS-02-07A:	TS1 43:	16 AWG	GN	118.11

CBL-4: EC-2198, DRAIN SOLENOID DIN CABLE

Label	Conductor ID	From	To	Section	Color	Length (in)
03-05B	WHT-2	SOL-03-07A:	TS1 13:	16 AWG	WH	118.11
03-07A	BLK-1	SOL-03-07A:	TS1 38:	16 AWG	BK	118.11
03-02A	GRN-GND	SOL-03-07A:	TS1 44:	16 AWG	GN	118.11

CBL-5: EC-1783, RESERVOIR LEVEL SENSOR CABLE

Label	Conductor ID	From	To	Section	Color	Length (in)
02-07B	BLU-F	LS-02-07A:	TS1 17:	18 AWG	BU	144
02-07C	RED-C	LS-02-07A:	TS1 18:	18 AWG	RD	144
02-07D	ORG-E	LS-02-07A:	TS1 18:	18 AWG	OG	144
02-04A	WHT/BLK-D	LS-02-07A:	TS1 19:	18 AWG	WHBK	144
02-05B	BLK-B	LS-02-07A:	TS1 20:	18 AWG	BK	144
02-07E	WHT-A	LS-02-07A:	TS1 21:	18 AWG	WH	144
02-06B	GRN-G	LS-02-07A:	TS1 43:	18 AWG	GN	144

CBL-6: EC-1170-06-108, STACK LIGHT CABLE

Label	Conductor ID	From	To	Section	Color	Length (in)
02-07R	WH	LT-02-09A: 0	TS1 12:	18 AWG	WH	0
02-07X	BK	LT-02-09A: 1	TS1 28:	18 AWG	BK	0
01-19B	GN	LT-02-09A: GND	TS1 42:	18 AWG	GN	0

CBL-7: EC-2956, CONTAMINATION MONITOR CABLE

Label	Conductor ID	From	To	Section	Color	Length (in)
03-08C	RED-8	CM-03-10A:	TS1 7:	22 AWG	RD	196.85
03-05A	BLU-7	CM-03-10A:	TS1 14:	22 AWG	BU	196.85

 <p>AIRCRAFT GROUND SUPPORT EQUIPMENT</p> <p>THIS DRAWING IS THE PROPERTY OF TRONAIR, INC. IT IS FURNISHED TO YOU FOR CONFIDENTIAL INFORMATION PURPOSES ONLY AND IS NOT TO BE DISCLOSED TO ANYONE OR REPRODUCED OR USED FOR MANUFACTURING PURPOSES WITHOUT THE EXPRESS WRITTEN PERMISSION OF TRONAIR, INC.</p>	DWN BY	NGL	CKD BY	PEH	DATE	7/25/2025
	<p>SCHEMATIC, ELECTRICAL</p>					
	<p>INS-2942</p>			SHEET	07 OF 09	REV

SYMBOL	DEVICE DESCRIPTION
	3-POLE CIRCUIT BREAKER SYMBOL PREFIX: CB
	2-POLE CIRCUIT BREAKER SYMBOL PREFIX: CB
	1-POLE CIRCUIT BREAKER SYMBOL PREFIX: CB
	3-POLE POWER DISTRIBUTION BLOCK SYMBOL PREFIX: PDB
	3-POLE CONTACTS NORMALLY OPEN
	3-POLE OVERLOAD RELAY SYMBOL PREFIX: OL
	PHASE MONITOR SYMBOL PREFIX: PM
	AC/DC POWER SUPPLY SYMBOL PREFIX: PSU
	CONTACTOR COIL SYMBOL PREFIX: CON
	CONTACT NORMALLY OPEN
	CONTACT NORMALLY CLOSED
	3-POLE CONTACTS NORMALLY OPEN

SYMBOL	DEVICE DESCRIPTION
	NORMALLY CLOSED MUSHROOM HEAD PUSHBUTTON SYMBOL PREFIX: PB
	NORMALLY CLOSED PUSHBUTTON SYMBOL PREFIX: PB
	NORMALLY CLOSED PUSHBUTTON CONTACT
	NORMALLY OPEN PUSHBUTTON SYMBOL PREFIX: PB
	NORMALLY OPEN PUSHBUTTON CONTACT
	SWITCH SPDT
	MAINTAINED SWITCH SPST SYMBOL PREFIX: SW
	LEVEL SWITCH NO & NC SYMBOL PREFIX: LS
	TEMPERATURE SWITCH NO & NC SYMBOL PREFIX: TS
	PRESSURE SWITCH NO & NC SYMBOL PREFIX: PS
	LATCHING CONTROL RELAY SYMBOL PREFIX: CR
	HOUR METER SYMBOL PREFIX: HM
	PILOT LIGHT (LAMP) SYMBOL PREFIX: LT
	LETTER INDICATES COLOR G = GREEN Y = YELLOW
	3 PHASE PUMP MOTOR WITH GROUND SYMBOL PREFIX: M
	GROUND STUD (CHASSIS) SYMBOL PREFIX: STUD

SYMBOL	DEVICE DESCRIPTION
	SOLENOID WITH GROUND SYMBOL PREFIX: PB
	ELECTRONIC MOTOR STARTER & OVERLOAD SYMBOL PREFIX: MS
	CONTAMINATION MONITOR SYMBOL PREFIX: CM
	TERMINAL BLOCK
	GROUNDING TERMINAL BLOCK

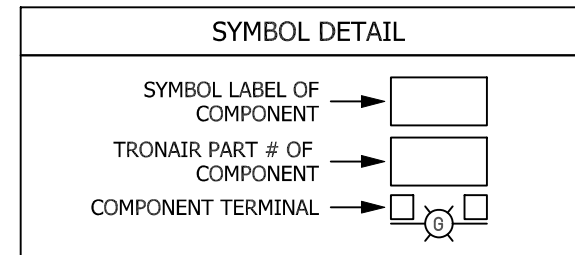
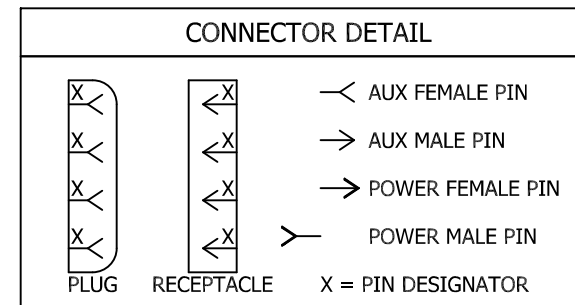
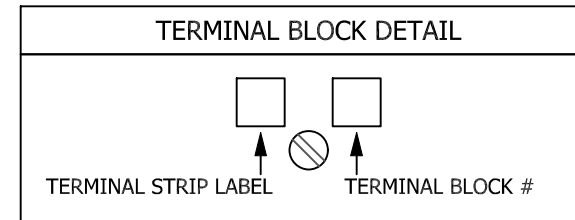
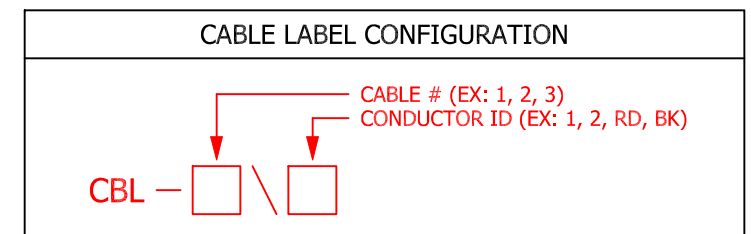
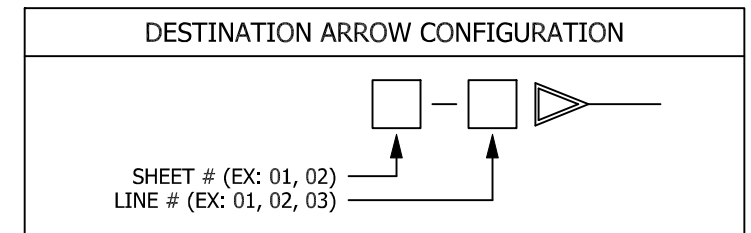
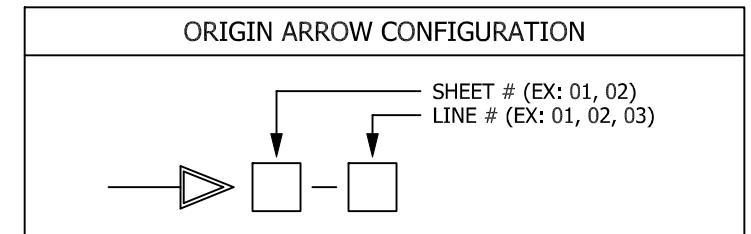
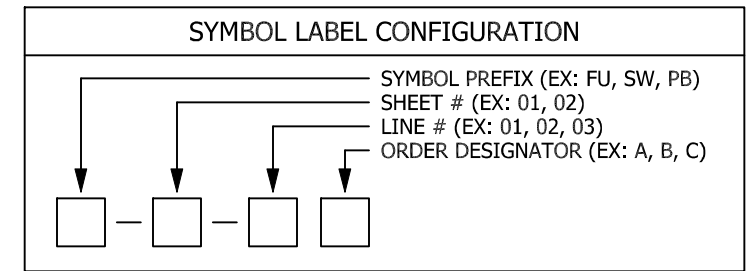
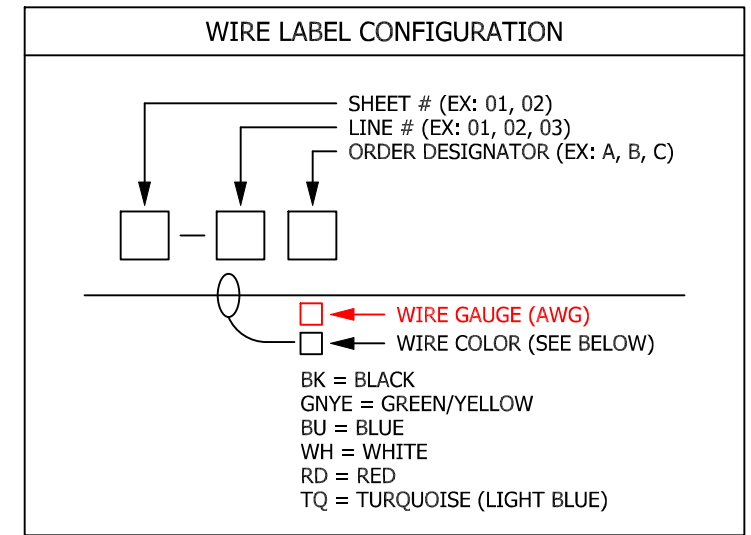

TRONAIR

AIRCRAFT GROUND
SUPPORT EQUIPMENT

DWN BY NGL CKD BY PEH DATE 7/25/2025

SCHEMATIC, ELECTRICAL

INS-2942 SHEET 08 OF 09 REV C

THIS DRAWING IS THE PROPERTY OF TRONAIR, INC. IT IS FURNISHED TO YOU FOR CONFIDENTIAL INFORMATION PURPOSES ONLY AND IS NOT TO BE DISCLOSED TO ANYONE OR REPRODUCED OR USED FOR MANUFACTURING PURPOSES WITHOUT THE EXPRESS WRITTEN PERMISSION OF TRONAIR, INC.

REVISION HISTORY

REV	DESCRIPTION	EC#	DWN	CHK	DATE
A	ORIGINAL RELEASE	28480	NGL	PEH	7/25/2025
B	MODIFIED AND CLARIFIED PART NUMBERS FOR VARIOUS CONFIGURATIONS AND RATINGS OF MOTOR CIRCUIT/HIGH VOLTAGE COMPONENTS	28304	NGL	PEH	10/6/2025
C	MODIFIED PHASE MONITOR PART NUMBER AND TERMINALS. ADDED CONTAMINATION MONITOR CABLE. ADDED STACK LIGHT CABLE.	30100	NGL	PEH	3/6/2026

 <p>AIRCRAFT GROUND SUPPORT EQUIPMENT</p> <p>THIS DRAWING IS THE PROPERTY OF TRONAIR, INC. IT IS FURNISHED TO YOU FOR CONFIDENTIAL INFORMATION PURPOSES ONLY AND IS NOT TO BE DISCLOSED TO ANYONE OR REPRODUCED OR USED FOR MANUFACTURING PURPOSES WITHOUT THE EXPRESS WRITTEN PERMISSION OF TRONAIR, INC.</p>	DWN BY	NGL	CKD BY	PEH	DATE	7/25/2025
	SCHEMATIC, ELECTRICAL					
	INS-2942			SHEET	09 OF 09	REV

DRAWING LIST

SHEET #	SHEET DESCRIPTION
00	DRAWING LIST
01	SCHEMATIC - MOTOR & HIGH VOLTAGE WIRING, GROUNDING
02	SCHEMATIC - INSTRUMENTATION & OPERATOR CONTROLS
03	SCHEMATIC - INSTRUMENTATION & OPERATOR CONTROLS (CONTINUED)
04	TERMINAL STRIP 1 LAYOUT
05	TERMINAL STRIP 1 LAYOUT (CONTINUED)
06	WIRE SCHEDULE
07	CABLE SCHEDULE
08	SYMBOLS LEGEND
09	REVISION HISTORY

 <p>TRONAIR</p> <p>AIRCRAFT GROUND SUPPORT EQUIPMENT</p> <p><small>THIS DRAWING IS THE PROPERTY OF TRONAIR, INC. IT IS FURNISHED TO YOU FOR CONFIDENTIAL INFORMATION PURPOSES ONLY AND IS NOT TO BE DISCLOSED TO ANYONE OR REPRODUCED OR USED FOR MANUFACTURING PURPOSES WITHOUT THE EXPRESS WRITTEN PERMISSION OF TRONAIR, INC.</small></p>	DWN BY	NGL	CKD BY	PEH	DATE	3/6/2026
	SCHEMATIC, ELECTRICAL, 575V					
	INS-2969			SHEET	00 OF 09	REV

01 40HP: 60HZ (208V, 230V, 380V, 460V) / 50HZ (200V, 220V, 380V, 415V, 440V)
 75HP: 60HZ (380V, 460V) / 50HZ (380V, 415V, 440V)

02
03
04
05
06
07
08
09
10
11
12
13
14
15
16
17
18
19

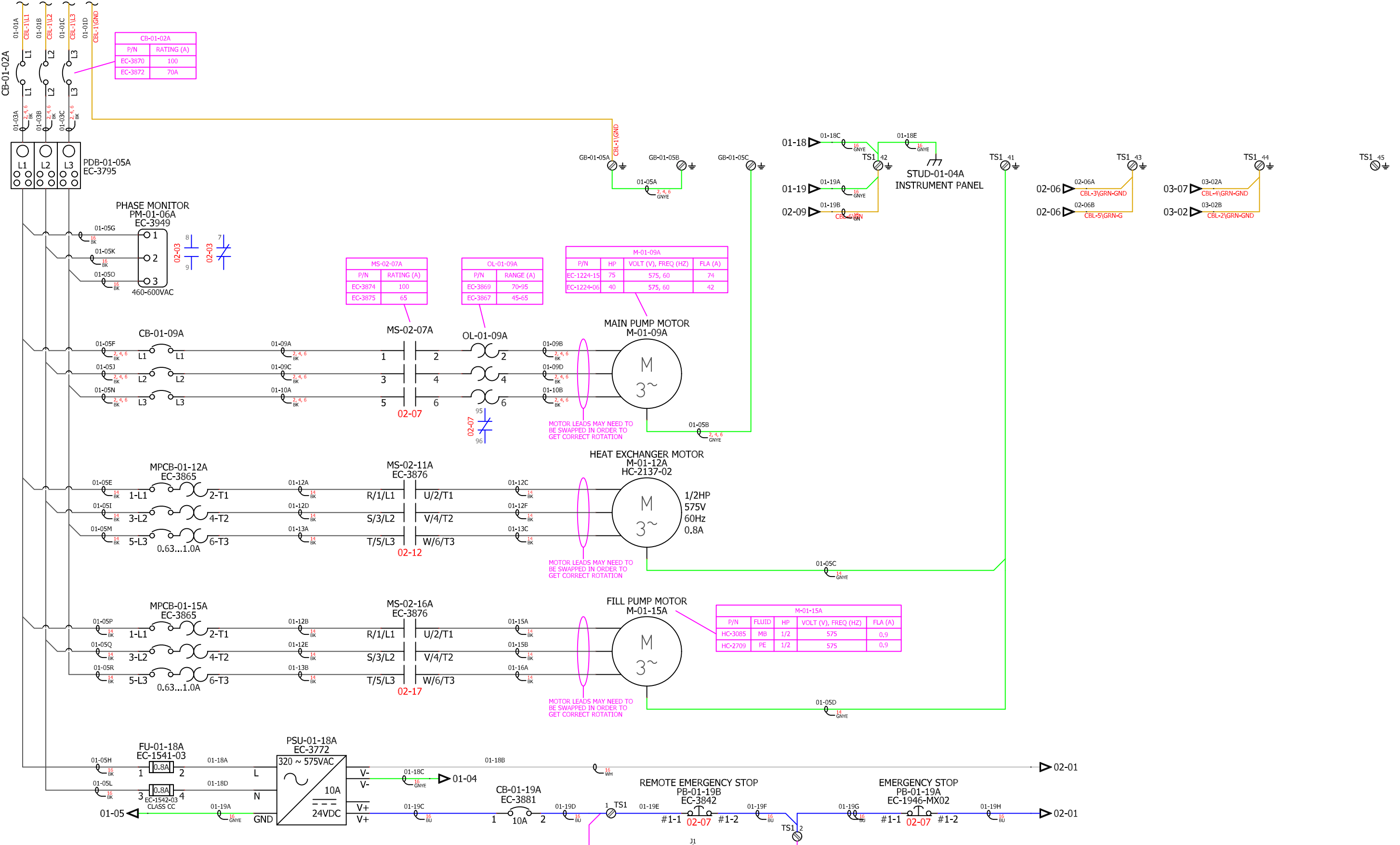

CB-01-02A	
P/N	RATING (A)
EC-3870	100
EC-3872	70A

MS-02-07A	
P/N	RATING (A)
EC-3874	100
EC-3875	65

OL-01-09A	
P/N	RANGE (A)
EC-3869	70-95
EC-3867	45-65

M-01-09A			
P/N	HP	VOLT (V), FREQ (HZ)	FLA (A)
EC-1224-15	75	575, 60	74
EC-1224-06	40	575, 60	42

M-01-15A				
P/N	FLUID	HP	VOLT (V), FREQ (HZ)	FLA (A)
HC-3085	MB	1/2	575	0.9
HC-2709	PE	1/2	575	0.9

TRONAIR
 AIRCRAFT GROUND SUPPORT EQUIPMENT

THIS DRAWING IS THE PROPERTY OF TRONAIR, INC. IT IS FURNISHED TO YOU FOR CONFIDENTIAL INFORMATION PURPOSES ONLY AND IS NOT TO BE DISCLOSED TO ANYONE OR REPRODUCED OR USED FOR MANUFACTURING PURPOSES WITHOUT THE EXPRESS WRITTEN PERMISSION OF TRONAIR, INC.

DWN BY	NGL	CKD BY	PEH	DATE	3/6/2026
SCHEMATIC, ELECTRICAL, 575V				SHEET	01 OF 09
INS-2969				REV	A

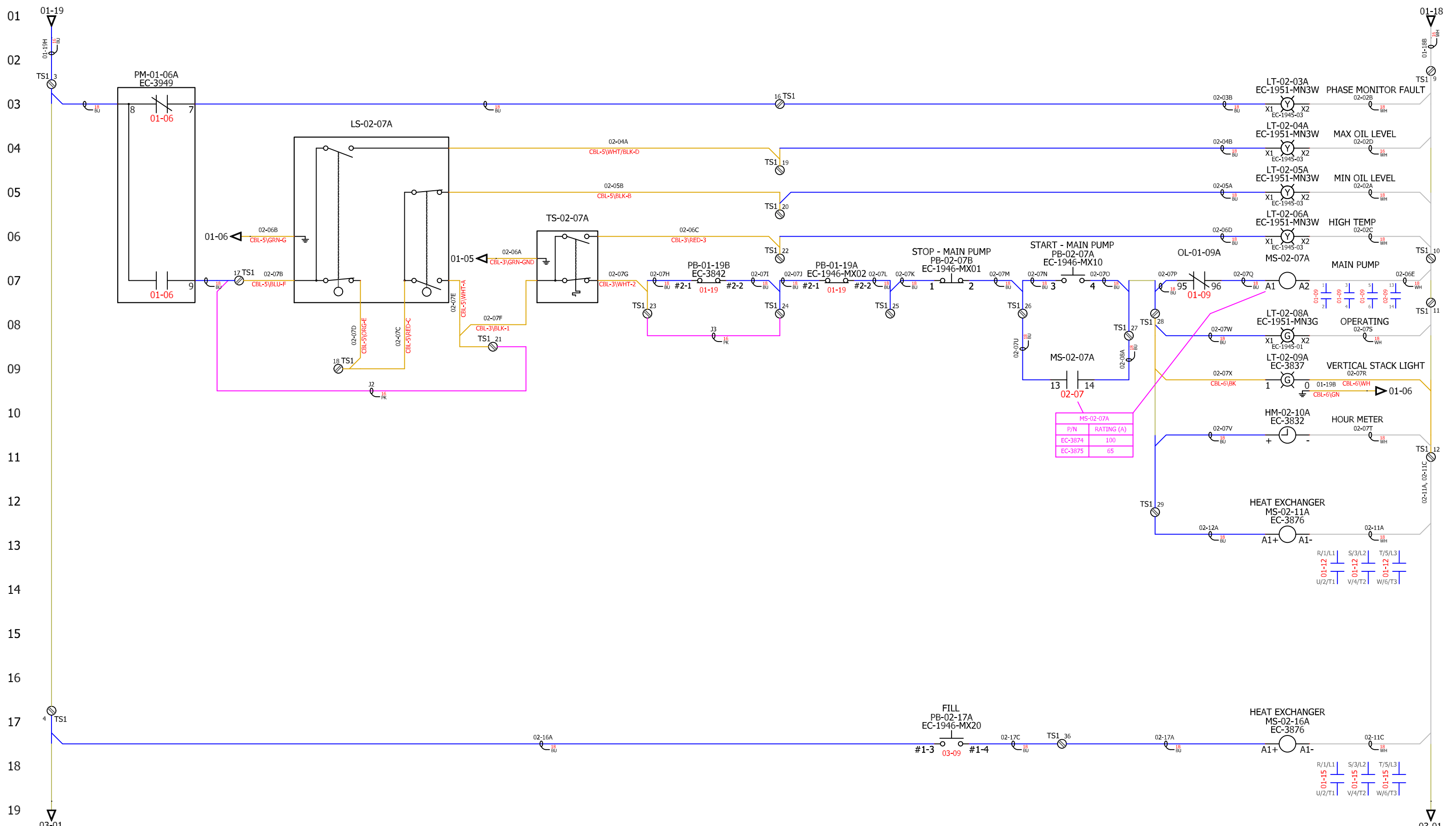

MS-02-07A	
P/N	RATING (A)
EC-3874	100
EC-3875	65

	AIRCRAFT GROUND SUPPORT EQUIPMENT	DWN BY NGL	CKD BY PEH	DATE 3/6/2026
	SCHEMATIC, ELECTRICAL, 575V			
	INS-2969	SHEET 02 OF 09	REV A	

THIS DRAWING IS THE PROPERTY OF TRONAIR, INC. IT IS FURNISHED TO YOU FOR CONFIDENTIAL INFORMATION PURPOSES ONLY AND IS NOT TO BE DISCLOSED TO ANYONE OR REPRODUCED OR USED FOR MANUFACTURING PURPOSES WITHOUT THE EXPRESS WRITTEN PERMISSION OF TRONAIR, INC.

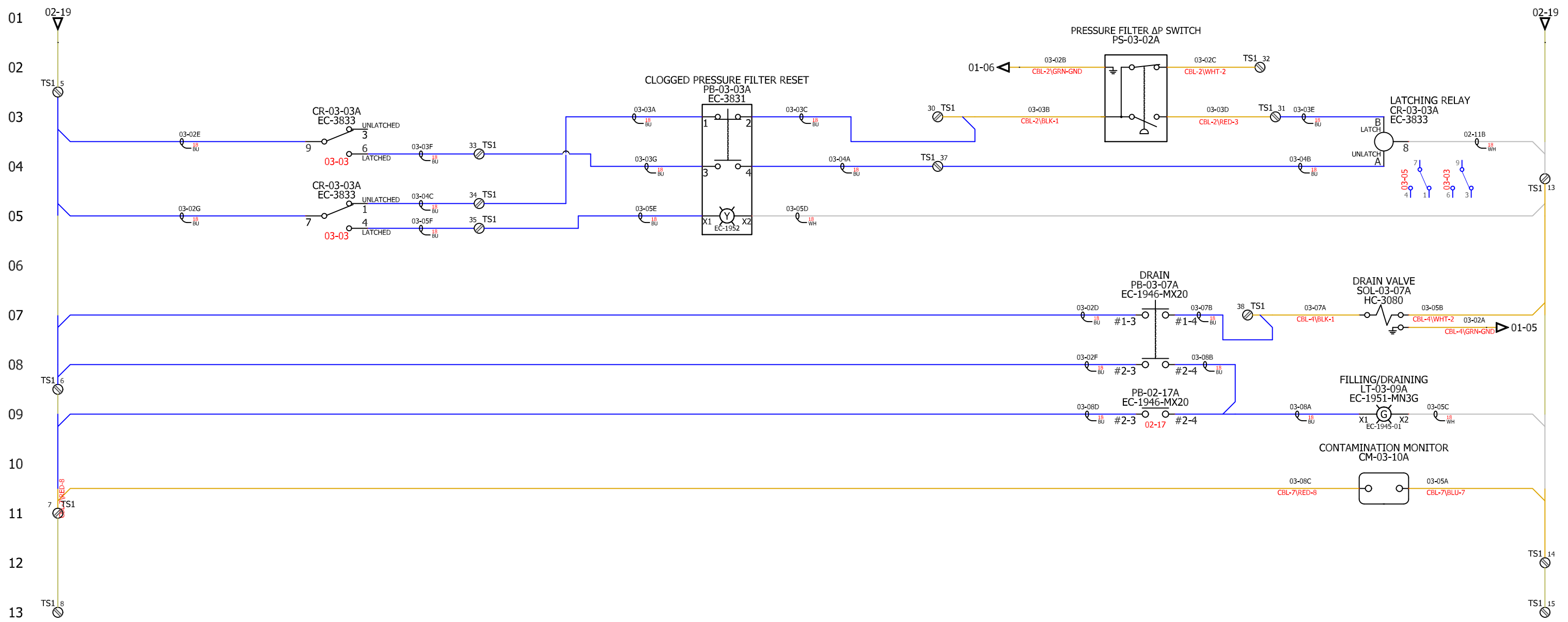

	AIRCRAFT GROUND SUPPORT EQUIPMENT		DWN BY	NGL	CKD BY	PEH	DATE	3/6/2026	
	SCHEMATIC, ELECTRICAL, 575V							SHEET	03 OF 09
	THIS DRAWING IS THE PROPERTY OF TRONAIR, INC. IT IS FURNISHED TO YOU FOR CONFIDENTIAL INFORMATION PURPOSES ONLY AND IS NOT TO BE DISCLOSED TO ANYONE OR REPRODUCED OR USED FOR MANUFACTURING PURPOSES WITHOUT THE EXPRESS WRITTEN PERMISSION OF TRONAIR, INC.							REV	A
			INS-2969						

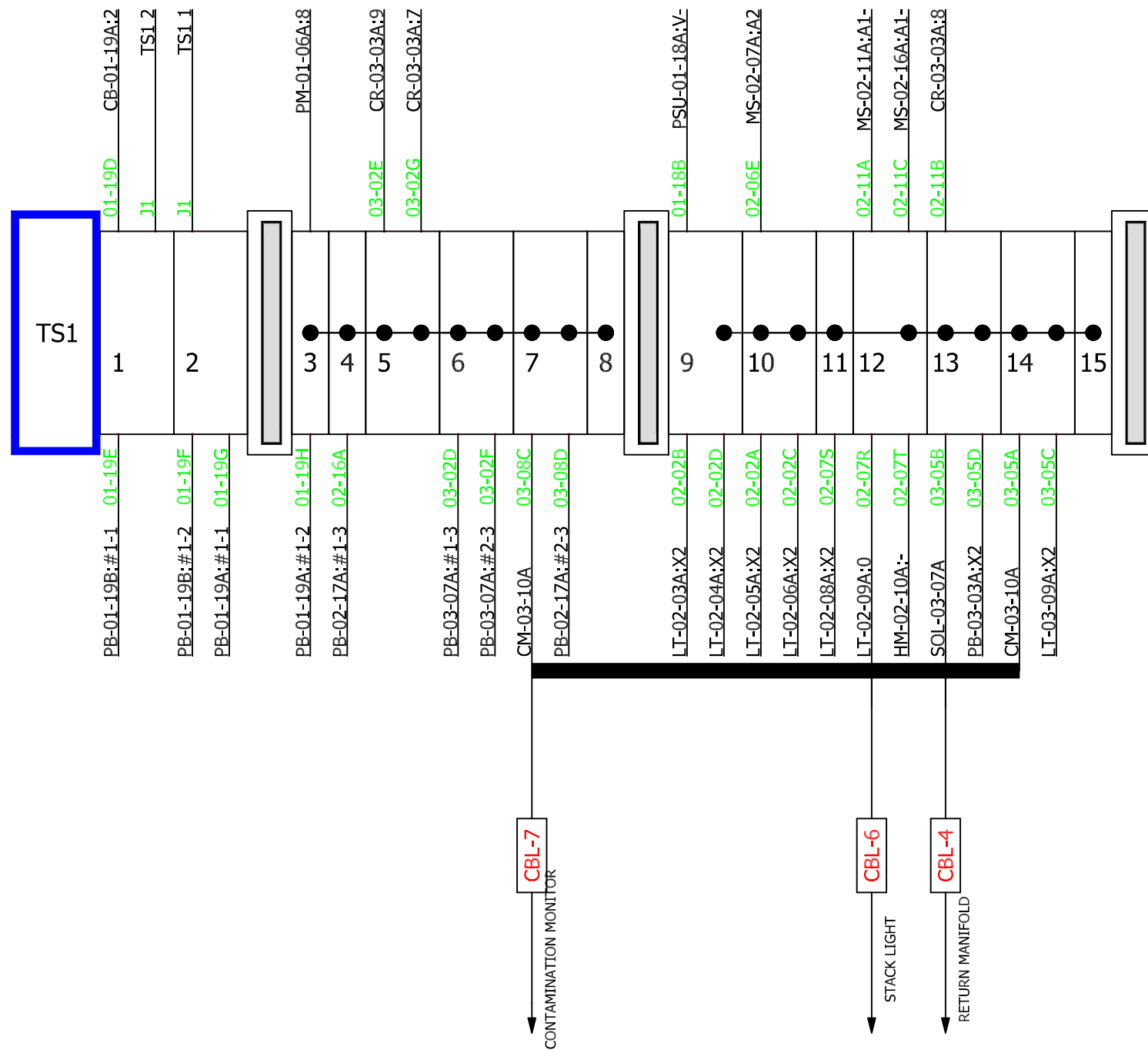

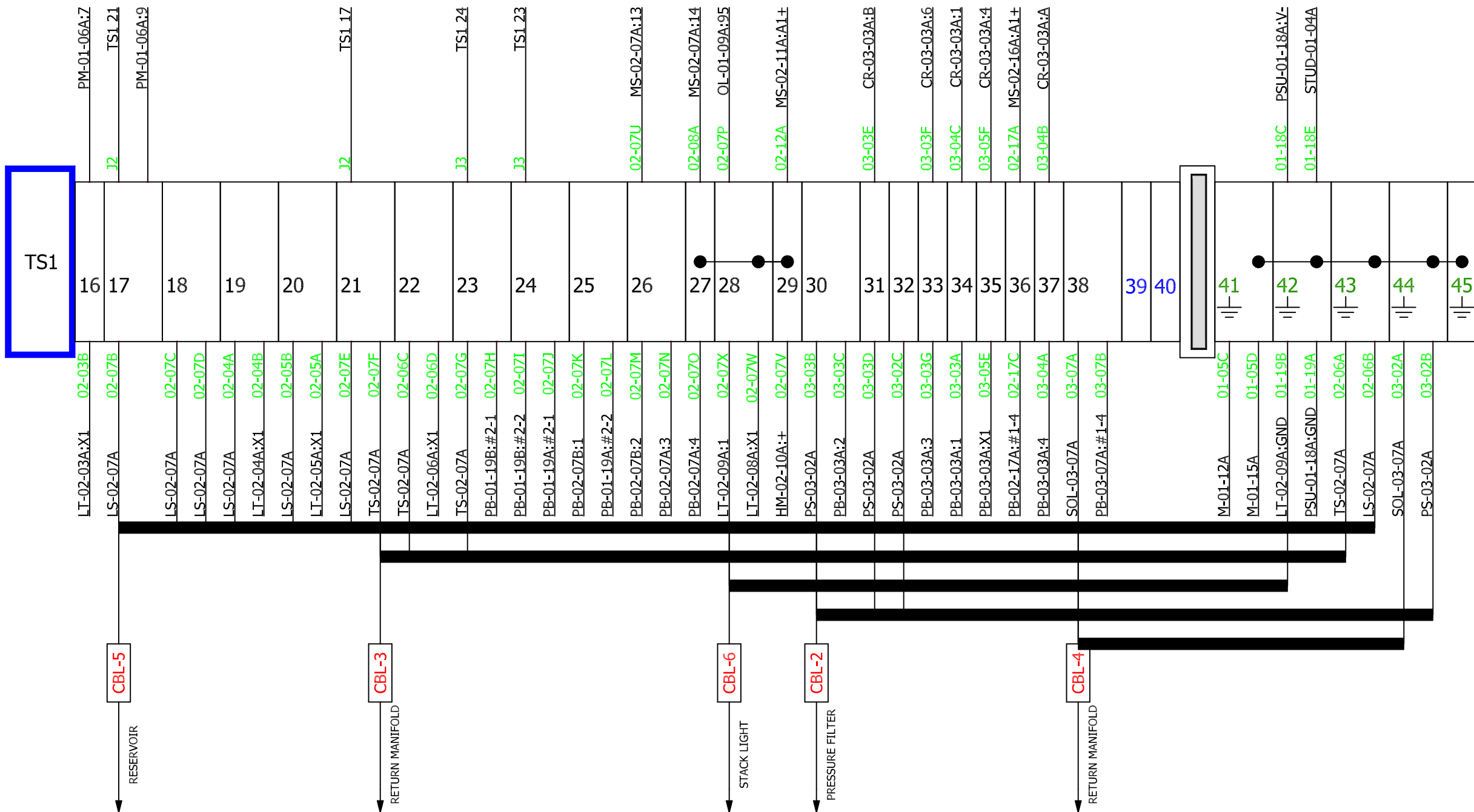

TS1

<p>AIRCRAFT GROUND SUPPORT EQUIPMENT</p> <p>THIS DRAWING IS THE PROPERTY OF TRONAIR, INC. IT IS FURNISHED TO YOU FOR CONFIDENTIAL INFORMATION PURPOSES ONLY AND IS NOT TO BE DISCLOSED TO ANYONE OR REPRODUCED OR USED FOR MANUFACTURING PURPOSES WITHOUT THE EXPRESS WRITTEN PERMISSION OF TRONAIR, INC.</p>	DWN BY NGL	CKD BY PEH	DATE 3/6/2026
	SCHEMATIC, ELECTRICAL, 575V		
	INS-2969	SHEET 05 OF 09	REV A

WIRE SCHEDULE

	Label	From	From Pin	To	To Pin	Section	Color	AC/DC
1	01-03A	CB-01-02A	L1	PDB-01-05A	L1	2, 4, 6 AWG	BK	AC
2	01-03B	CB-01-02A	L2	PDB-01-05A	L2	2, 4, 6 AWG	BK	AC
3	01-03C	CB-01-02A	L3	PDB-01-05A	L3	2, 4, 6 AWG	BK	AC
4	01-09A	CB-01-09A	L1	MS-02-07A	1	2, 4, 6 AWG	BK	AC
5	01-09C	CB-01-09A	L2	MS-02-07A	3	2, 4, 6 AWG	BK	AC
6	01-10A	CB-01-09A	L3	MS-02-07A	5	2, 4, 6 AWG	BK	AC
7	01-05F	CB-01-09A	L1	PDB-01-05A	L1	2, 4, 6 AWG	BK	AC
8	01-05J	CB-01-09A	L2	PDB-01-05A	L2	2, 4, 6 AWG	BK	AC
9	01-05N	CB-01-09A	L3	PDB-01-05A	L3	2, 4, 6 AWG	BK	AC
10	01-09B	M-01-09A		OL-01-09A	2	2, 4, 6 AWG	BK	AC
11	01-09D	M-01-09A		OL-01-09A	4	2, 4, 6 AWG	BK	AC
12	01-10B	M-01-09A		OL-01-09A	6	2, 4, 6 AWG	BK	AC
13	01-05A	GB-01-05A		GB-01-05B		2, 4, 6 AWG	GNYE	
14	01-05B	GB-01-05C		M-01-09A		2, 4, 6 AWG	GNYE	
15	01-12C	M-01-12A		MS-02-11A	U/2/T1	14 AWG	BK	AC
16	01-12F	M-01-12A		MS-02-11A	V/4/T2	14 AWG	BK	AC
17	01-13C	M-01-12A		MS-02-11A	W/6/T3	14 AWG	BK	AC
18	01-15A	M-01-15A		MS-02-16A	U/2/T1	14 AWG	BK	AC
19	01-15B	M-01-15A		MS-02-16A	V/4/T2	14 AWG	BK	AC
20	01-16A	M-01-15A		MS-02-16A	W/6/T3	14 AWG	BK	AC
21	01-12A	MPCB-01-12A	2-T1	MS-02-11A	R/1/L1	14 AWG	BK	AC
22	01-12D	MPCB-01-12A	4-T2	MS-02-11A	S/3/L2	14 AWG	BK	AC
23	01-13A	MPCB-01-12A	6-T3	MS-02-11A	T/5/L3	14 AWG	BK	AC
24	01-05E	MPCB-01-12A	1-L1	PDB-01-05A	L1	14 AWG	BK	AC
25	01-05I	MPCB-01-12A	3-L2	PDB-01-05A	L2	14 AWG	BK	AC
26	01-05M	MPCB-01-12A	5-L3	PDB-01-05A	L3	14 AWG	BK	AC
27	01-12B	MPCB-01-15A	2-T1	MS-02-16A	R/1/L1	14 AWG	BK	AC
28	01-12E	MPCB-01-15A	4-T2	MS-02-16A	S/3/L2	14 AWG	BK	AC
29	01-13B	MPCB-01-15A	6-T3	MS-02-16A	T/5/L3	14 AWG	BK	AC
30	01-05P	MPCB-01-15A	1-L1	PDB-01-05A	L1	14 AWG	BK	AC
31	01-05Q	MPCB-01-15A	3-L2	PDB-01-05A	L2	14 AWG	BK	AC
32	01-05R	MPCB-01-15A	5-L3	PDB-01-05A	L3	14 AWG	BK	AC
33	01-05C	M-01-12A		TS1 41		14 AWG	GNYE	GND
34	01-05D	M-01-15A		TS1 41		14 AWG	GNYE	GND
35	01-05H	FU-01-18A	1	PDB-01-05A	L1	16 AWG	BK	AC
36	01-05L	FU-01-18A	3	PDB-01-05A	L2	16 AWG	BK	AC
37	01-18A	FU-01-18A	2	PSU-01-18A	L	16 AWG	BK	AC
38	01-18D	FU-01-18A	4	PSU-01-18A	N	16 AWG	BK	AC
39	01-05G	PM-01-06A	1	PDB-01-05A	L1	16 AWG	BK	AC
40	01-05K	PM-01-06A	2	PDB-01-05A	L2	16 AWG	BK	AC
41	01-05O	PM-01-06A	3	PDB-01-05A	L3	16 AWG	BK	AC
42	01-19C	CB-01-19A	1	PSU-01-18A	V+	16 AWG	BU	DC
43	01-19D	CB-01-19A	2	TS1 1		16 AWG	BU	DC
44	01-19E	TS1 1		PB-01-19B	#1-1	16 AWG	BU	DC
45	01-19G	TS1 2		PB-01-19A	#1-1	16 AWG	BU	DC
46	01-19F	TS1 2		PB-01-19B	#1-2	16 AWG	BU	DC
47	01-19H	TS1 3		PB-01-19A	#1-2	16 AWG	BU	DC
48	01-18C	PSU-01-18A	V-	TS1 42		16 AWG	GNYE	GND
49	01-19A	PSU-01-18A	GND	TS1 42		16 AWG	GNYE	GND
50	01-18E	STUD-01-04A		TS1 42		16 AWG	GNYE	GND
51	J1	TS1 2		TS1 1		16 AWG	PK	
52	J2	TS1 21		TS1 17		16 AWG	PK	
53	J3	TS1 23		TS1 24		16 AWG	PK	
54	01-18B	PSU-01-18A	V-	TS1 9		16 AWG	WH	DC
55	02-02D	TS1 9		LT-02-04A	X2	16 AWG	WH	DC
56	03-03E	CR-03-03A	B	TS1 31		18 AWG	BU	DC
57	03-03F	CR-03-03A	6	TS1 33		18 AWG	BU	DC
58	03-04C	CR-03-03A	1	TS1 34		18 AWG	BU	DC
59	03-05F	CR-03-03A	4	TS1 35		18 AWG	BU	DC
60	03-04B	CR-03-03A	A	TS1 37		18 AWG	BU	DC

	Label	From	From Pin	To	To Pin	Section	Color	AC/DC
61	02-07V	HM-02-10A	+	TS1 29		18 AWG	BU	DC
62	03-08A	LT-03-09A	X1	PB-02-17A	#2-4	18 AWG	BU	DC
63	02-07Q	MS-02-07A	A1	OL-01-09A	96	18 AWG	BU	DC
64	02-07U	MS-02-07A	13	TS1 26		18 AWG	BU	DC
65	02-08A	MS-02-07A	14	TS1 27		18 AWG	BU	DC
66	02-07P	OL-01-09A	95	TS1 28		18 AWG	BU	DC
67	02-07H	PB-01-19B	#2-1	TS1 23		18 AWG	BU	DC
68	02-07O	PB-02-07A	4	TS1 27		18 AWG	BU	DC
69	02-07M	PB-02-07B	2	TS1 26		18 AWG	BU	DC
70	03-08B	PB-02-17A	#2-4	PB-03-07A	#2-4	18 AWG	BU	DC
71	03-08D	PB-02-17A	#2-3	TS1 7		18 AWG	BU	DC
72	02-17C	PB-02-17A	#1-4	TS1 36		18 AWG	BU	DC
73	03-03G	PB-03-03A	3	TS1 33		18 AWG	BU	DC
74	03-03A	PB-03-03A	1	TS1 34		18 AWG	BU	DC
75	03-05E	PB-03-03A	X1	TS1 35		18 AWG	BU	DC
76	03-04A	PB-03-03A	4	TS1 37		18 AWG	BU	DC
77	03-02D	PB-03-07A	#1-3	TS1 6		18 AWG	BU	DC
78	03-02F	PB-03-07A	#2-3	TS1 6		18 AWG	BU	DC
79		PM-01-06A	8	TS1 3		18 AWG	BU	DC
80		PM-01-06A	7	TS1 16		18 AWG	BU	DC
81		PM-01-06A	9	TS1 17		18 AWG	BU	DC
82	02-16A	TS1 4		PB-02-17A	#1-3	18 AWG	BU	DC
83	03-02E	TS1 5		CR-03-03A	9	18 AWG	BU	DC
84	03-02G	TS1 5		CR-03-03A	7	18 AWG	BU	DC
85	02-03B	TS1 16		LT-02-03A	X1	18 AWG	BU	DC
86	02-04B	TS1 19		LT-02-04A	X1	18 AWG	BU	DC
87	02-05A	TS1 20		LT-02-05A	X1	18 AWG	BU	DC
88	02-06D	TS1 22		LT-02-06A	X1	18 AWG	BU	DC
89	02-07J	TS1 24		PB-01-19A	#2-1	18 AWG	BU	DC
90	02-07I	TS1 24		PB-01-19B	#2-2	18 AWG	BU	DC
91	02-07L	TS1 25		PB-01-19A	#2-2	18 AWG	BU	DC
92	02-07K	TS1 25		PB-02-07B	1	18 AWG	BU	DC
93	02-07N	TS1 26		PB-02-07A	3	18 AWG	BU	DC
94	02-07W	TS1 28		LT-02-08A	X1	18 AWG	BU	DC
95	02-12A	TS1 29		MS-02-11A	A1+	18 AWG	BU	DC
96	03-03C	TS1 30		PB-03-03A	2	18 AWG	BU	DC
97	02-17A	TS1 36		MS-02-16A	A1+	18 AWG	BU	DC
98	03-07B	TS1 38		PB-03-07A	#1-4	18 AWG	BU	DC
99	02-11B	CR-03-03A	8	TS1 13		18 AWG	WH	DC
100	02-07T	HM-02-10A	-	TS1 12		18 AWG	WH	DC
101	02-02B	LT-02-03A	X2	TS1 9		18 AWG	WH	DC
102	02-02A	LT-02-05A	X2	TS1 10		18 AWG	WH	DC
103	02-02C	LT-02-06A	X2	TS1 10		18 AWG	WH	DC
104	02-07S	LT-02-08A	X2	TS1 11		18 AWG	WH	DC
105	03-05C	LT-03-09A	X2	TS1 14		18 AWG	WH	DC
106	02-06E	TS1 10		MS-02-07A	A2	18 AWG	WH	DC
107	02-11A	TS1 12		MS-02-11A	A1-	18 AWG	WH	DC
108	02-11C	TS1 12		MS-02-16A	A1-	18 AWG	WH	DC
109	03-05D	TS1 13		PB-03-03A	X2	18 AWG	WH	DC



AIRCRAFT GROUND SUPPORT EQUIPMENT

DWN BY NGL CKD BY PEH DATE 3/6/2026

SCHEMATIC, ELECTRICAL, 575V

THIS DRAWING IS THE PROPERTY OF TRONAIR, INC. IT IS FURNISHED TO YOU FOR CONFIDENTIAL INFORMATION PURPOSES ONLY AND IS NOT TO BE DISCLOSED TO ANYONE OR REPRODUCED OR USED FOR MANUFACTURING PURPOSES WITHOUT THE EXPRESS WRITTEN PERMISSION OF TRONAIR, INC.

INS-2969 SHEET 06 OF 09 REV A

CABLE SCHEDULE

CBL-1: EC-1227-XX*XXXX, INPUT POWER CABLE

Label	Conductor ID	From	To	Section	Color	Length (in)
01-01A	L1	CB-01-02A: L1	INPUT POWER: L1	AWG		0
01-01B	L2	CB-01-02A: L2	INPUT POWER: L2	AWG		0
01-01C	L3	CB-01-02A: L3	INPUT POWER: L3	AWG		0
01-01D	GND	GB-01-05A:	INPUT POWER: GND	AWG	GN	0

CBL-2: EC-2198, PRESSURE FILTER DIN CABLE

Label	Conductor ID	From	To	Section	Color	Length (in)
03-03B	BLK-1	PS-03-02A:	TS1 30:	16 AWG	BK	118.11
03-03D	RED-3	PS-03-02A:	TS1 31:	16 AWG	RD	118.11
03-02C	WHT-2	PS-03-02A:	TS1 32:	16 AWG	WH	118.11
03-02B	GRN-GND	PS-03-02A:	TS1 44:	16 AWG	GN	118.11

CBL-3: EC-2198, TEMPERATURE SWITCH DIN CABLE

Label	Conductor ID	From	To	Section	Color	Length (in)
02-07F	BLK-1	TS-02-07A:	TS1 21:	16 AWG	BK	118.11
02-06C	RED-3	TS-02-07A:	TS1 22:	16 AWG	RD	118.11
02-07G	WHT-2	TS-02-07A:	TS1 23:	16 AWG	WH	118.11
02-06A	GRN-GND	TS-02-07A:	TS1 43:	16 AWG	GN	118.11

CBL-4: EC-2198, DRAIN SOLENOID DIN CABLE

Label	Conductor ID	From	To	Section	Color	Length (in)
03-05B	WHT-2	SOL-03-07A:	TS1 13:	16 AWG	WH	118.11
03-07A	BLK-1	SOL-03-07A:	TS1 38:	16 AWG	BK	118.11
03-02A	GRN-GND	SOL-03-07A:	TS1 44:	16 AWG	GN	118.11

CBL-5: EC-1783, RESERVOIR LEVEL SENSOR CABLE

Label	Conductor ID	From	To	Section	Color	Length (in)
02-07B	BLU-F	LS-02-07A:	TS1 17:	18 AWG	BU	144
02-07C	RED-C	LS-02-07A:	TS1 18:	18 AWG	RD	144
02-07D	ORG-E	LS-02-07A:	TS1 18:	18 AWG	OG	144
02-04A	WHT/BLK-D	LS-02-07A:	TS1 19:	18 AWG	WHBK	144
02-05B	BLK-B	LS-02-07A:	TS1 20:	18 AWG	BK	144
02-07E	WHT-A	LS-02-07A:	TS1 21:	18 AWG	WH	144
02-06B	GRN-G	LS-02-07A:	TS1 43:	18 AWG	GN	144

CBL-6: EC-1170-06-108, STACK LIGHT CABLE

Label	Conductor ID	From	To	Section	Color	Length (in)
02-07R	WH	LT-02-09A: 0	TS1 12:	18 AWG	WH	0
02-07X	BK	LT-02-09A: 1	TS1 28:	18 AWG	BK	0
01-19B	GN	LT-02-09A: GND	TS1 42:	18 AWG	GN	0

CBL-7: EC-2956, CONTAMINATION MONITOR CABLE

Label	Conductor ID	From	To	Section	Color	Length (in)
03-08C	RED-8	CM-03-10A:	TS1 7:	22 AWG	RD	196.85
03-05A	BLU-7	CM-03-10A:	TS1 14:	22 AWG	BU	196.85

TRONAIR
AIRCRAFT GROUND SUPPORT EQUIPMENT

THIS DRAWING IS THE PROPERTY OF TRONAIR, INC. IT IS FURNISHED TO YOU FOR CONFIDENTIAL INFORMATION PURPOSES ONLY AND IS NOT TO BE DISCLOSED TO ANYONE OR REPRODUCED OR USED FOR MANUFACTURING PURPOSES WITHOUT THE EXPRESS WRITTEN PERMISSION OF TRONAIR, INC.

DWN BY	NGL	CKD BY	PEH	DATE	3/6/2026
SCHEMATIC, ELECTRICAL, 575V					
INS-2969			SHEET	07 OF 09	REV A

SYMBOL	DEVICE DESCRIPTION
	3-POLE CIRCUIT BREAKER SYMBOL PREFIX: CB
	2-POLE CIRCUIT BREAKER SYMBOL PREFIX: CB
	1-POLE CIRCUIT BREAKER SYMBOL PREFIX: CB
	3-POLE POWER DISTRIBUTION BLOCK SYMBOL PREFIX: PDB
	3-POLE CONTACTS NORMALLY OPEN
	3-POLE OVERLOAD RELAY SYMBOL PREFIX: OL
	PHASE MONITOR SYMBOL PREFIX: PM
	AC/DC POWER SUPPLY SYMBOL PREFIX: PSU
	CONTACTOR COIL SYMBOL PREFIX: CON
	CONTACT NORMALLY OPEN
	CONTACT NORMALLY CLOSED
	3-POLE CONTACTS NORMALLY OPEN

SYMBOL	DEVICE DESCRIPTION
	NORMALLY CLOSED MUSHROOM HEAD PUSHBUTTON SYMBOL PREFIX: PB
	NORMALLY CLOSED PUSHBUTTON SYMBOL PREFIX: PB
	NORMALLY CLOSED PUSHBUTTON CONTACT
	NORMALLY OPEN PUSHBUTTON SYMBOL PREFIX: PB
	NORMALLY OPEN PUSHBUTTON CONTACT
	SWITCH SPDT
	MAINTAINED SWITCH SPST SYMBOL PREFIX: SW
	LEVEL SWITCH NO & NC SYMBOL PREFIX: LS
	TEMPERATURE SWITCH NO & NC SYMBOL PREFIX: TS
	PRESSURE SWITCH NO & NC SYMBOL PREFIX: PS
	LATCHING CONTROL RELAY SYMBOL PREFIX: CR
	HOUR METER SYMBOL PREFIX: HM
	PILOT LIGHT (LAMP) SYMBOL PREFIX: LT
	LETTER INDICATES COLOR G = GREEN Y = YELLOW
	3 PHASE PUMP MOTOR WITH GROUND SYMBOL PREFIX: M
	GROUND STUD (CHASSIS) SYMBOL PREFIX: STUD

SYMBOL	DEVICE DESCRIPTION
	SOLENOID WITH GROUND SYMBOL PREFIX: PB
	ELECTRONIC MOTOR STARTER & OVERLOAD SYMBOL PREFIX: MS
	CONTAMINATION MONITOR SYMBOL PREFIX: CM
	TERMINAL BLOCK
	GROUNDING TERMINAL BLOCK

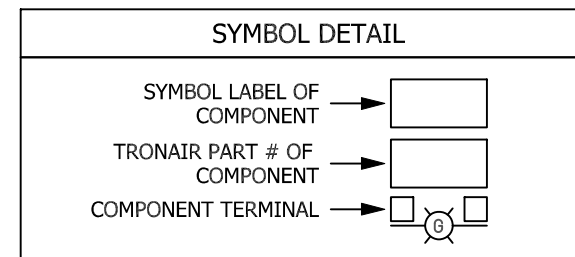
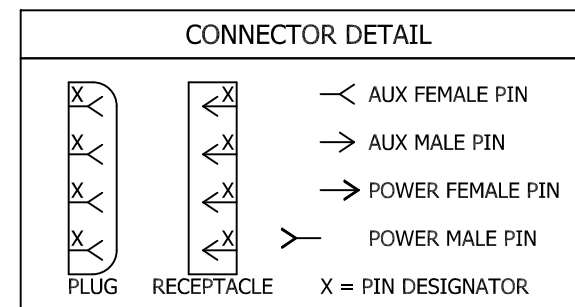
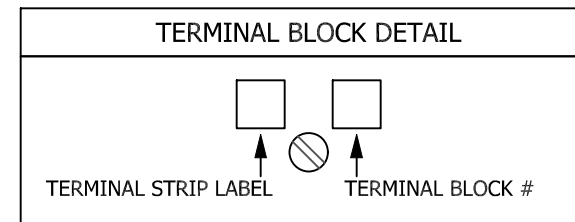
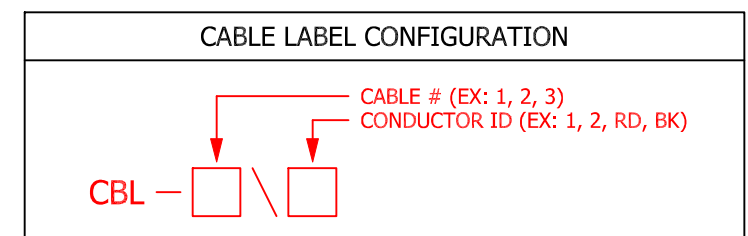
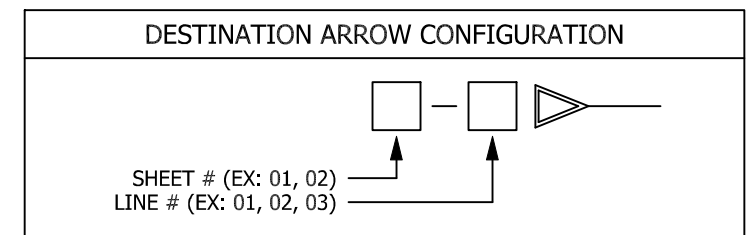
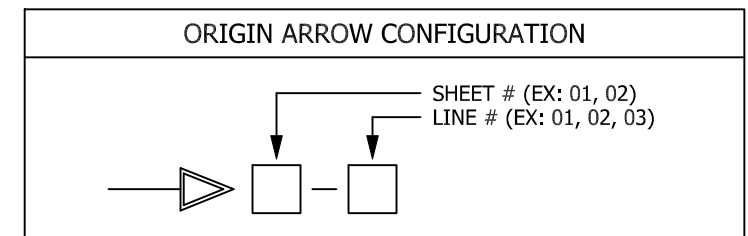
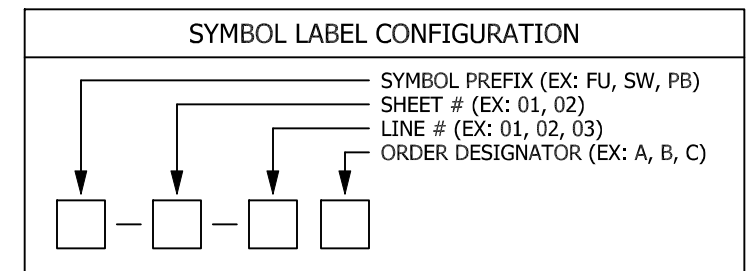
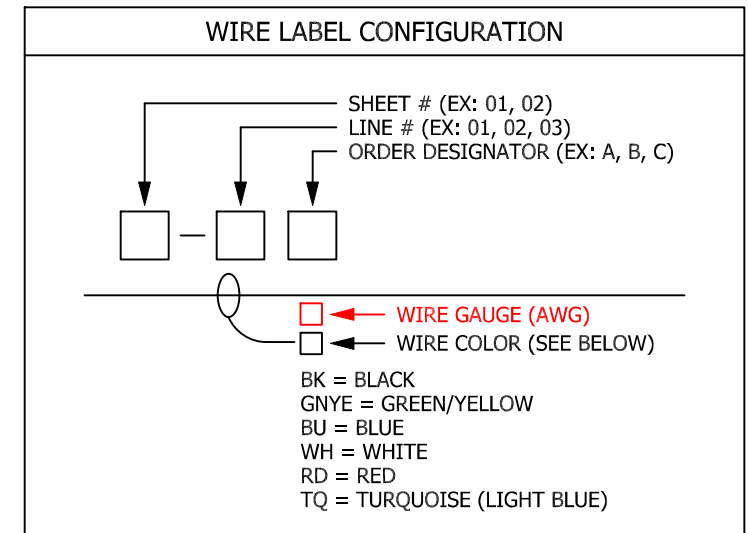

TRONAIR

AIRCRAFT GROUND
SUPPORT EQUIPMENT

DWN BY NGL CKD BY PEH DATE 3/6/2026

SCHEMATIC, ELECTRICAL, 575V

INS-2969 SHEET 08 OF 09 REV A

THIS DRAWING IS THE PROPERTY OF TRONAIR, INC. IT IS FURNISHED TO YOU FOR CONFIDENTIAL INFORMATION PURPOSES ONLY AND IS NOT TO BE DISCLOSED TO ANYONE OR REPRODUCED OR USED FOR MANUFACTURING PURPOSES WITHOUT THE EXPRESS WRITTEN PERMISSION OF TRONAIR, INC.

REVISION HISTORY

REV	DESCRIPTION	EC#	DWN	CHK	DATE
A	ORIGINAL RELEASE	30100	NGL	PEH	3/6/2026



THIS DRAWING IS THE PROPERTY OF TRONAIR, INC. IT IS FURNISHED TO YOU FOR CONFIDENTIAL INFORMATION PURPOSES ONLY AND IS NOT TO BE DISCLOSED TO ANYONE OR REPRODUCED OR USED FOR MANUFACTURING PURPOSES WITHOUT THE EXPRESS WRITTEN PERMISSION OF TRONAIR, INC.

DWN BY	NGL	CKD BY	PEH	DATE	3/6/2026
--------	-----	--------	-----	------	----------

SCHEMATIC, ELECTRICAL, 575V

INS-2969	SHEET	09 OF 09	REV	A
-----------------	-------	----------	-----	---



APPENDIX IV

Wiring Diagram (INS-2947)

THIS DRAWING IS THE PROPERTY OF TRONAIR, INC. IT IS FURNISHED TO YOU FOR CONFIDENTIAL INFORMATION PURPOSES ONLY AND IS NOT TO BE DISCLOSED TO ANYONE OR REPRODUCED OR USED FOR MANUFACTURING PURPOSES WITHOUT THE EXPRESS WRITTEN PERMISSION OF TRONAIR, INC.

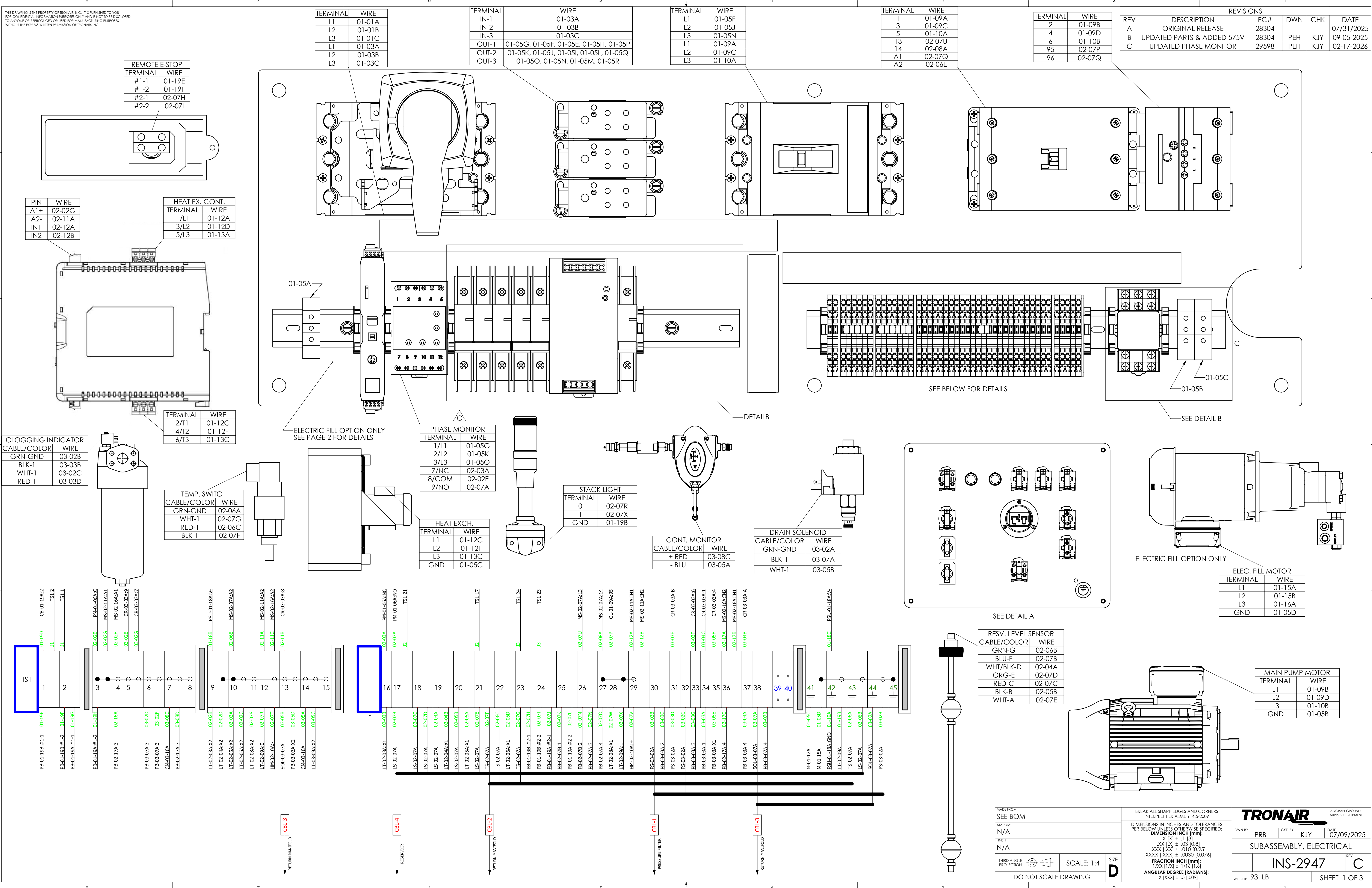

TERMINAL	WIRE
L1	01-01A
L2	01-01B
L3	01-01C
L1	01-03A
L2	01-03B
L3	01-03C

TERMINAL	WIRE
IN-1	01-03A
IN-2	01-03B
IN-3	01-03C
OUT-1	01-05G, 01-05F, 01-05E, 01-05H, 01-05P
OUT-2	01-05K, 01-05J, 01-05I, 01-05L, 01-05Q
OUT-3	01-05O, 01-05N, 01-05M, 01-05R

TERMINAL	WIRE
L1	01-05F
L2	01-05J
L3	01-05N
L1	01-09A
L2	01-09C
L3	01-10A

TERMINAL	WIRE
1	01-09A
3	01-09C
5	01-10A
13	02-07U
14	02-08A
A1	02-07Q
A2	02-06E

TERMINAL	WIRE
2	01-09B
4	01-09D
6	01-10B
95	02-07P
96	02-07Q

REVISIONS					
REV	DESCRIPTION	EC#	DWN	CHK	DATE
A	ORIGINAL RELEASE	28304	-	-	07/31/2025
B	UPDATED PARTS & ADDED 575V	28304	PEH	KJY	09-05-2025
C	UPDATED PHASE MONITOR	29598	PEH	KJY	02-17-2026

REMOTE E-STOP	
TERMINAL	WIRE
#1-1	01-19E
#1-2	01-19F
#2-1	02-07H
#2-2	02-07I

PIN	WIRE
A1+	02-02G
A2-	02-11A
IN1	02-12A
IN2	02-12B

HEAT EX. CONT.	
TERMINAL	WIRE
1/L1	01-12A
3/L2	01-12D
5/L3	01-13A

TERMINAL	WIRE
2/T1	01-12C
4/T2	01-12F
6/T3	01-13C

CLOGGING INDICATOR	
CABLE/COLOR	WIRE
GRN-GND	03-02B
BLK-1	03-03B
WHT-1	03-02C
RED-1	03-03D

TEMP. SWITCH	
CABLE/COLOR	WIRE
GRN-GND	02-06A
WHT-1	02-07G
RED-1	02-06C
BLK-1	02-07F

PHASE MONITOR	
TERMINAL	WIRE
1/L1	01-05G
2/L2	01-05K
3/L3	01-05O
7/NC	02-03A
8/COM	02-02E
9/NO	02-07A

HEAT EXCH.	
TERMINAL	WIRE
L1	01-12C
L2	01-12F
L3	01-13C
GND	01-05C

STACK LIGHT	
TERMINAL	WIRE
0	02-07R
1	02-07X
GND	01-19B

CONT. MONITOR	
CABLE/COLOR	WIRE
+ RED	03-08C
- BLU	03-05A

DRAIN SOLENOID	
CABLE/COLOR	WIRE
GRN-GND	03-02A
BLK-1	03-07A
WHT-1	03-05B

RESV. LEVEL SENSOR	
CABLE/COLOR	WIRE
GRN-G	02-06B
BLU-F	02-07B
WHT/BLK-D	02-04A
ORG-E	02-07D
RED-C	02-07C
BLK-B	02-05B
WHT-A	02-07E

ELEC. FILL MOTOR	
TERMINAL	WIRE
L1	01-15A
L2	01-15B
L3	01-16A
GND	01-05D

MAIN PUMP MOTOR	
TERMINAL	WIRE
L1	01-09B
L2	01-09D
L3	01-10B
GND	01-05B

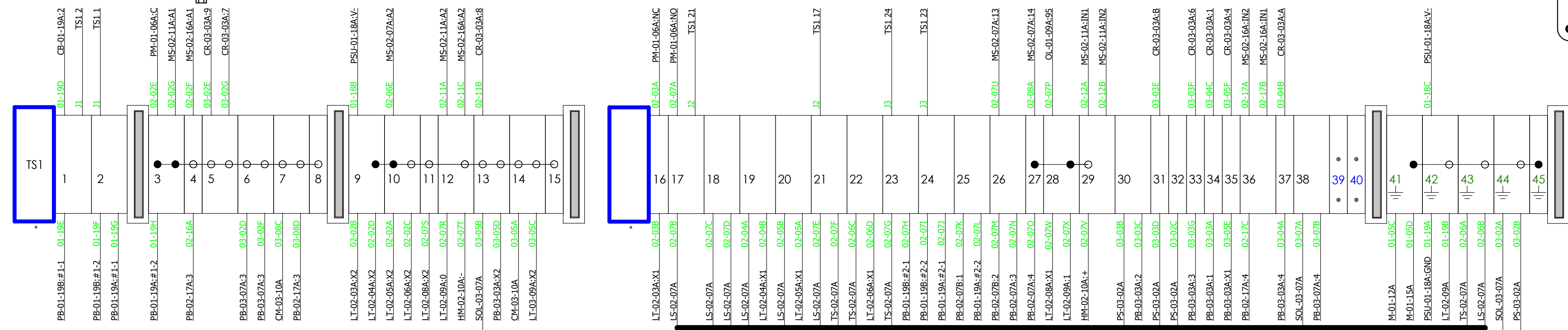

MADE FROM SEE BOM	BREAK ALL SHARP EDGES AND CORNERS INTERPRET PER ASME Y14.5-2009	TRONAIR <small>AIRCRAFT GROUND SUPPORT EQUIPMENT</small>
MATERIAL N/A	DIMENSIONS IN INCHES AND TOLERANCES PER BELOW UNLESS OTHERWISE SPECIFIED: DIMENSION INCH [mm]: .XX [X] ± .13 .XX [X] ± .03 [0.8] .XXX [XXX] ± .010 [0.25] .XXXX [XXXX] ± .0030 [0.076] FRACTION INCH [mm]: 1/XX [1/X] ± 1/16 [1.6] ANGULAR DEGREE [RADIAN]: X [XXX] ± .5 [0.09]	
THIRD ANGLE PROJECTION	SCALE: 1:4	CKD BY KJY
DO NOT SCALE DRAWING	SIZE D	DATE 07/09/2025
SUBASSEMBLY, ELECTRICAL		REV C
WEIGHT: 93 LB		SHEET 1 OF 3

ELECTRIC FILL OPTION ONLY

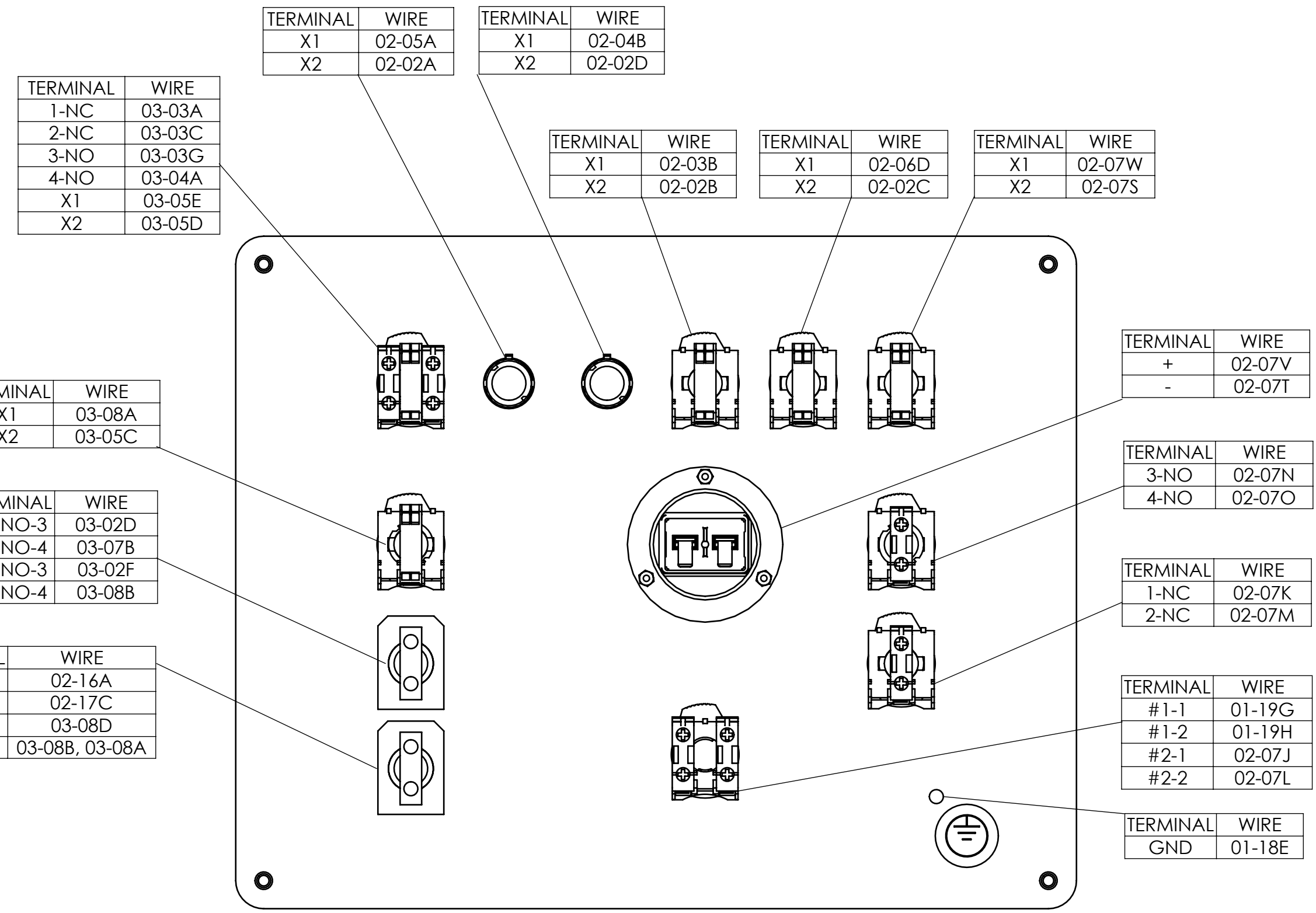

DETAIL A

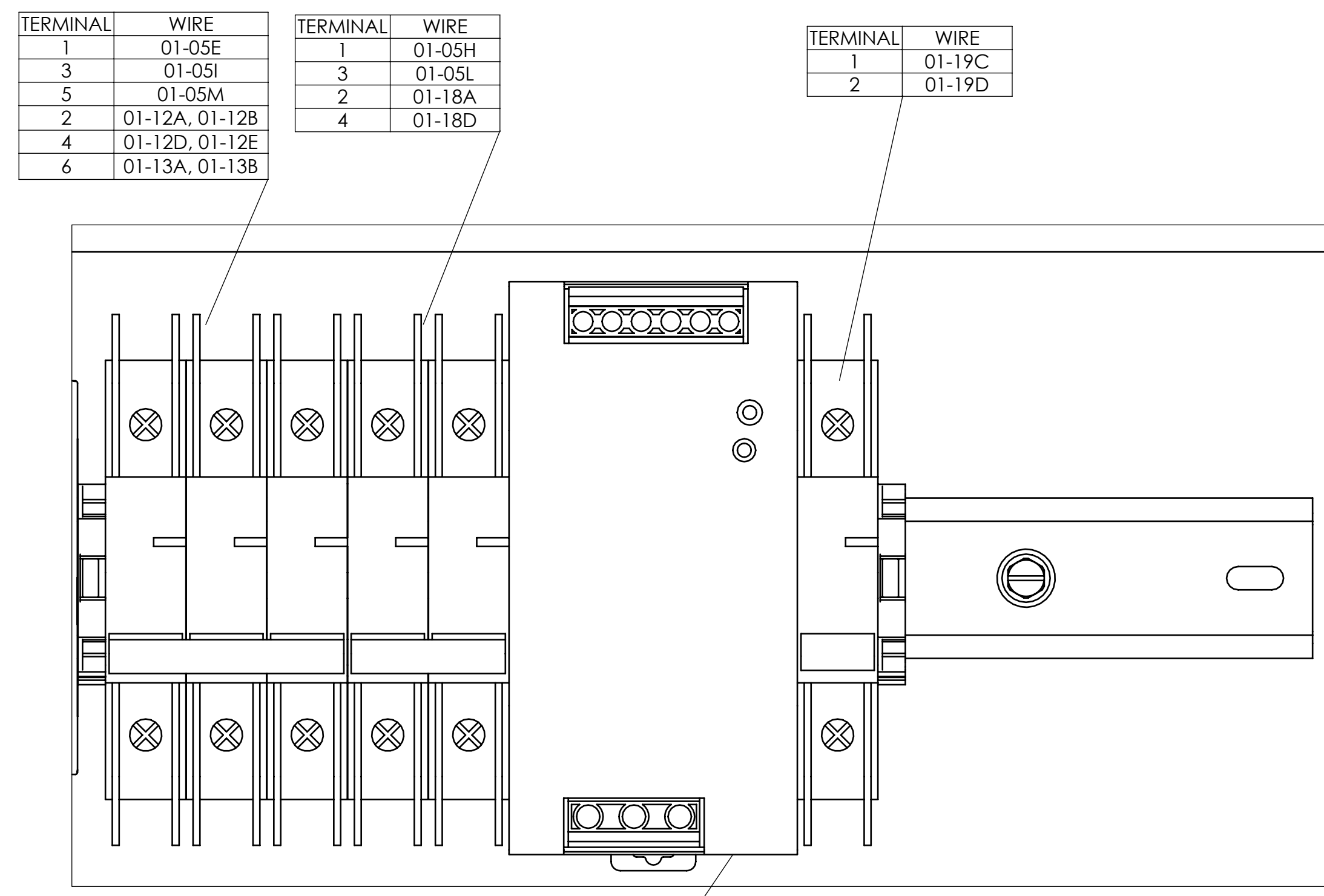

DETAIL B

TERMINAL	WIRE
L	01-18A
N	01-18D
GND	01-19A
V-	01-18B
V-	01-18C
V+	01-19C

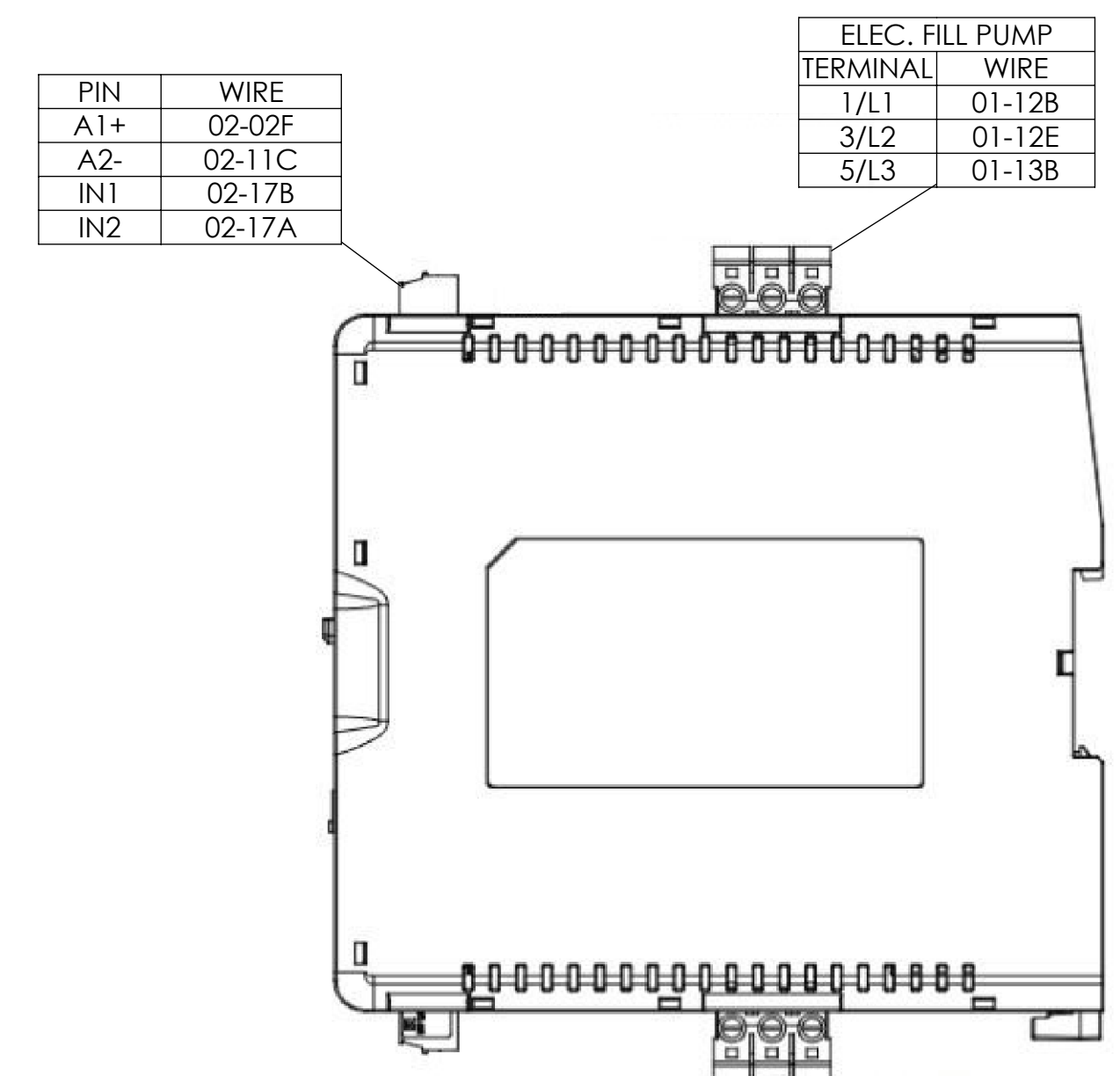

ELECTRIC FILL OPTION ONLY

LATCH RELAY	
TERMINAL	WIRE
6	03-03F
9	0302E
1	03-04C
4	03-05F
7	03-02G
A	03-04B
B	03-03E
8	02-11B

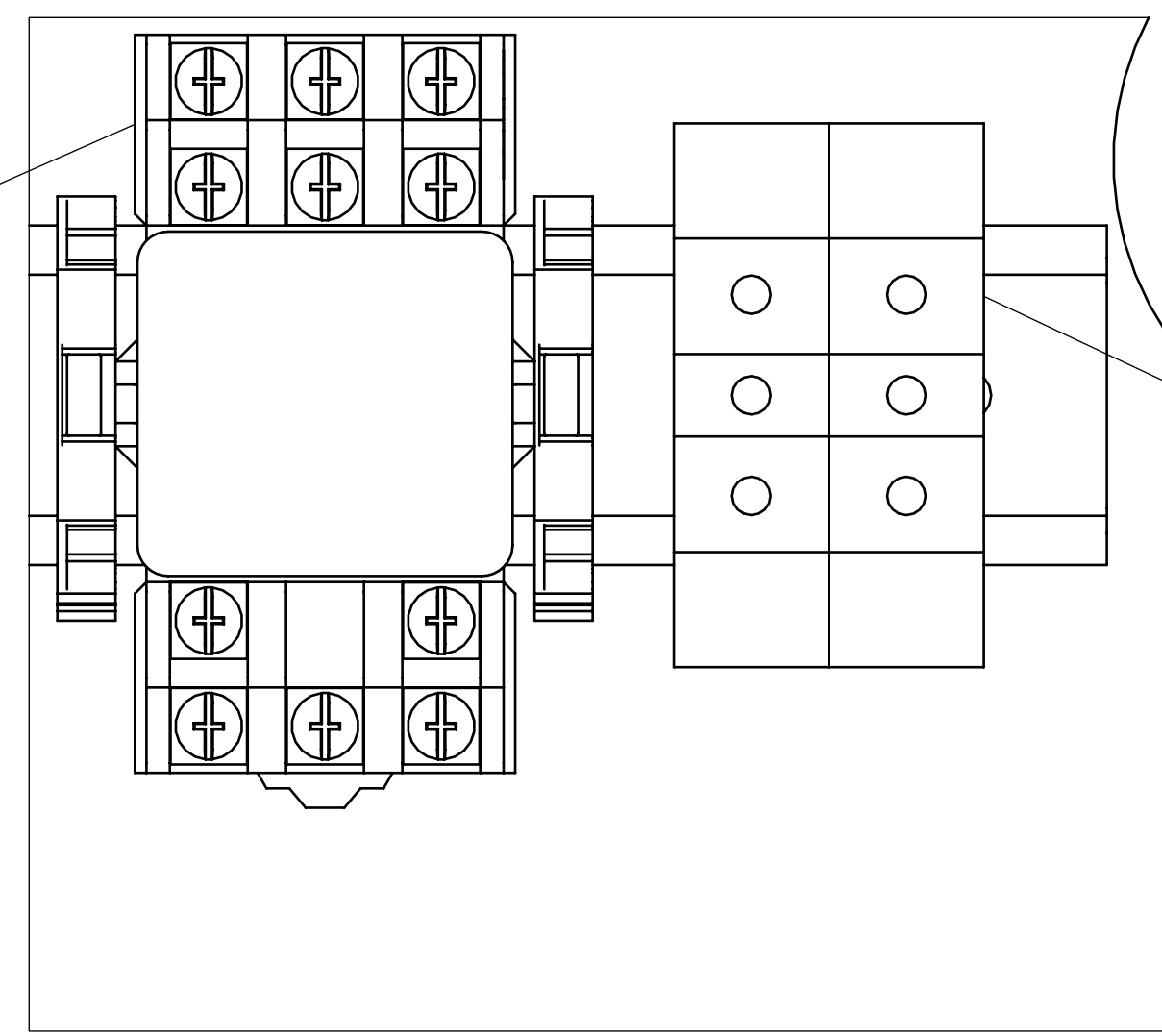

DETAIL C SCALE 4 : 3

GROUND TERMINAL	
TERMINAL	WIRE
LEFT	01-05B
RIGHT	01-05C

PROPRIETARY AND CONFIDENTIAL
 THE INFORMATION CONTAINED IN THIS DRAWING IS THE SOLE PROPERTY OF...
 REPRODUCTION IN PART OR AS A WHOLE WITHOUT THE WRITTEN PERMISSION OF... IS PROHIBITED.

UNLESS OTHERWISE SPECIFIED:		NAME		DATE
DIMENSIONS ARE IN INCHES		DRAWN		
TOLERANCES:		CHECKED		
FRACTIONAL ±		ENG APPR.		
ANGULAR ±		MFG APPR.		
TWO PLACE DECIMAL ±				
THREE PLACE DECIMAL ±				
INTERPRET GEOMETRIC TOLERANCING PER:		Q.A. COMMENTS:		
MATERIAL	N/A			
FINISH	N/A			
NEXT ASSY	USED ON			
APPLICATION	DO NOT SCALE DRAWING			

TITLE:	ASSEMBLY, ELECTRICAL INSTRUMENT	
SIZE	DWG. NO.	REV
D	INS-2947	C
SCALE: 1:2	WEIGHT: 4.42	SHEET 2 OF 3

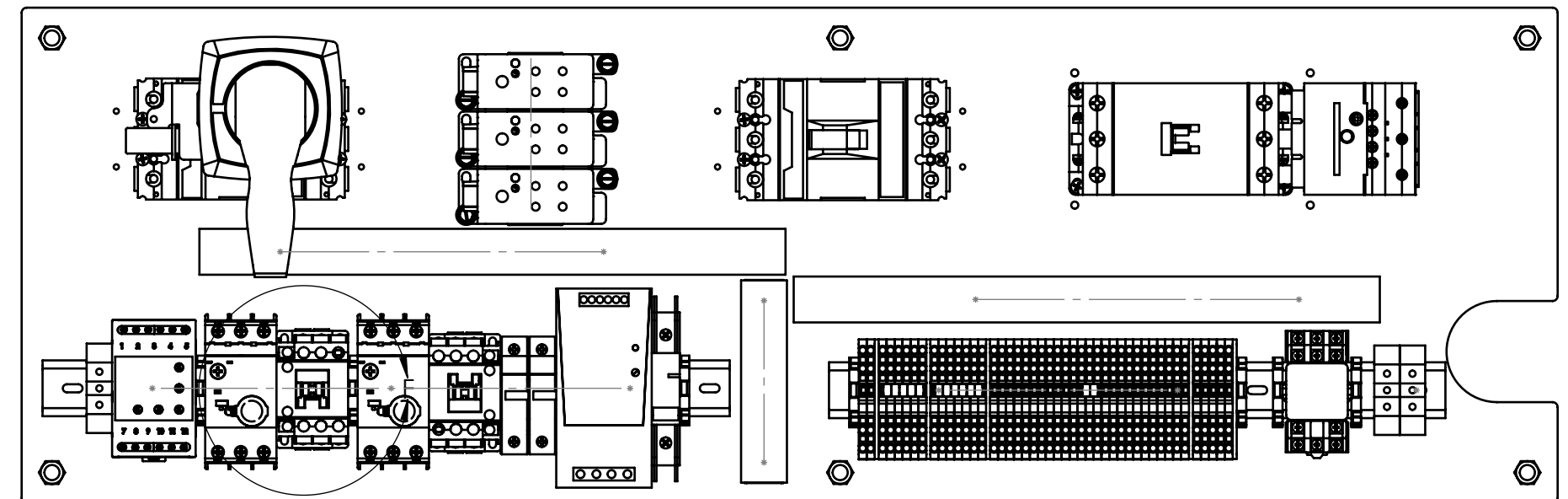
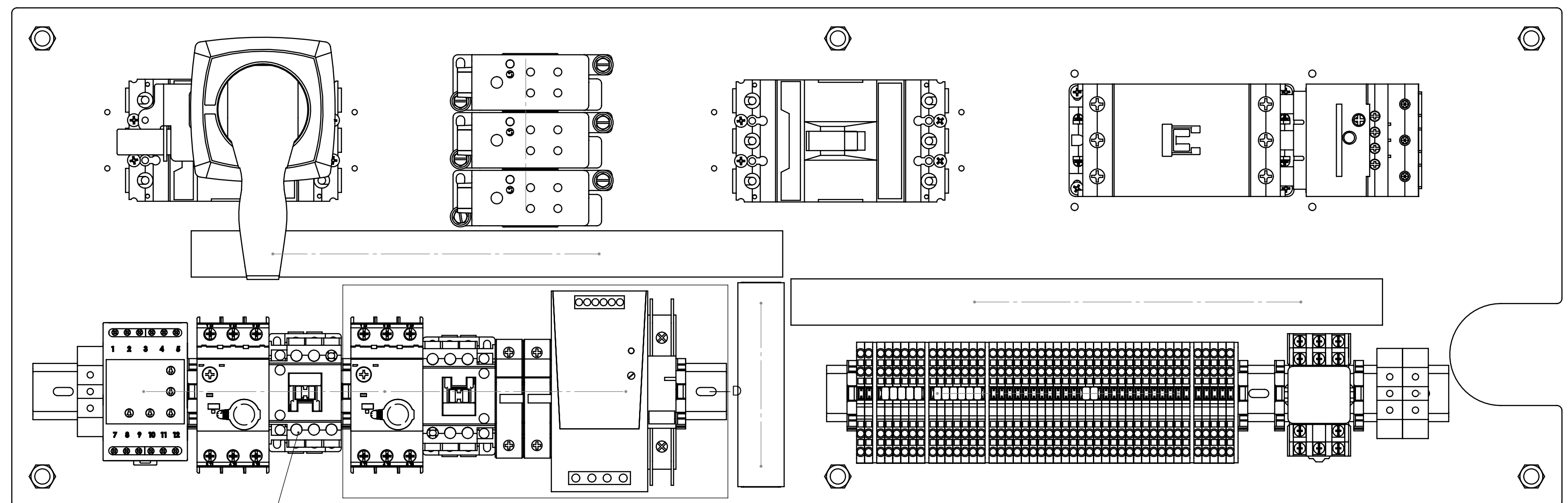

ELECTRIC FILL OPTION SEE DETAILS E&F

HEAT EXCH. MOTOR	
TERMINAL	WIRE
1-L1	01-05E
3-L2	01-05I
5-L3	01-05M
2-T1	01-12A
4-T2	01-12D
6-T3	01-13A

HEAT EXCH. MOTOR	
TERMINAL	WIRE
R/1/L1	01-12A
S/3/L2	01-12D
T/5/L3	01-13A
U/2/T1	01-12C
V/4/T2	01-12F
W/6/T3	01-13C

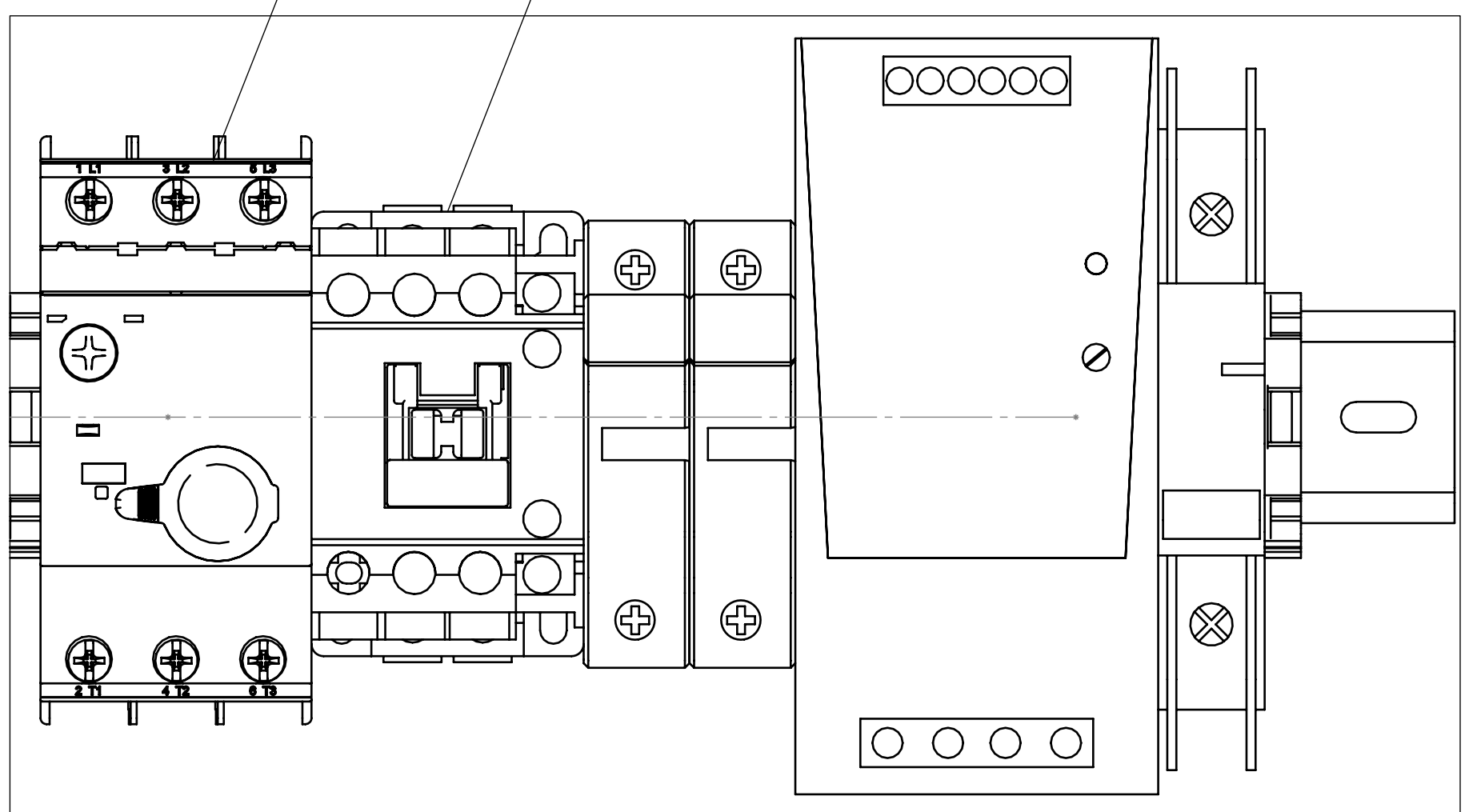

DETAIL D
SCALE 1 : 1

FILL PUMP MOTOR	
TERMINAL	WIRE
1-L1	01-05P
3-L2	01-05Q
5-L3	01-05R
2-T1	01-12B
4-T2	01-12E
6-T3	01-13B

FILL PUMP MOTOR	
TERMINAL	WIRE
R/1/L1	01-12B
S/3/L2	01-12E
T/5/L3	01-13B
U/2/T1	01-15A
V/4/T2	01-15B
W/6/T3	01-16A

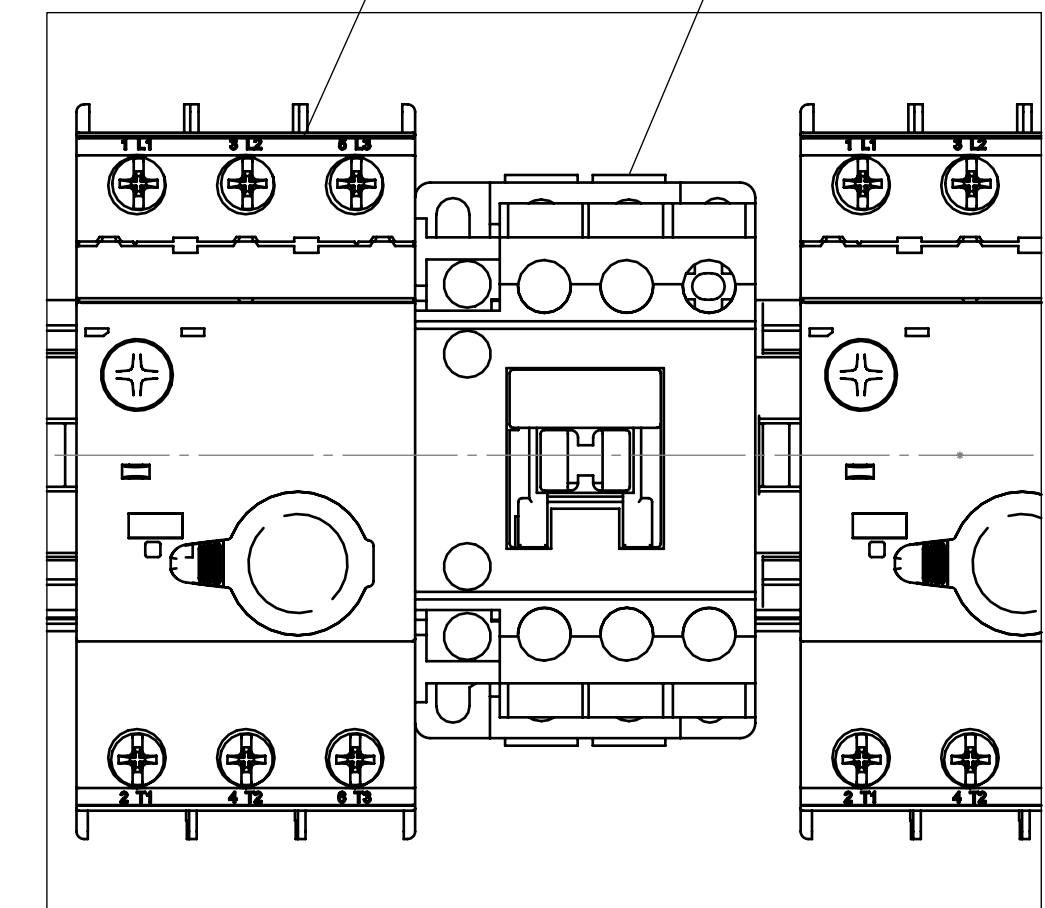

DETAIL F
SCALE 1 : 1

DIST. BLOCK	
TERMINAL	WIRE
OUT 1	01-05P, 01-05E
OUT 2	01-05Q, 01-05I
OUT 3	01-05R, 01-05M

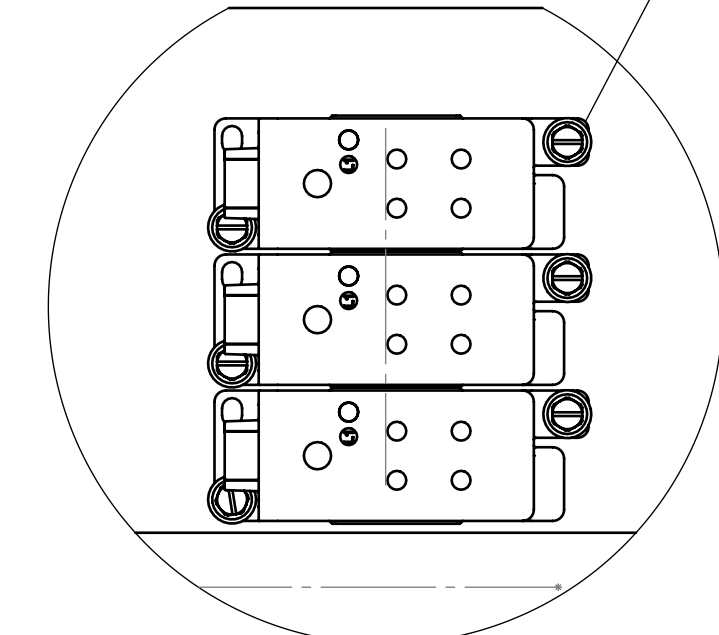

DETAIL E
SCALE 1 : 2

575V WITH ELECTRIC FILL PUMP

575V ASSEMBLIES (-02 AND -03 ONLY)

PROPRIETARY AND CONFIDENTIAL
THE INFORMATION CONTAINED IN THIS DRAWING IS THE SOLE PROPERTY OF...
REPRODUCTION IN PART OR AS A WHOLE WITHOUT THE WRITTEN PERMISSION OF... IS PROHIBITED.

UNLESS OTHERWISE SPECIFIED: DIMENSIONS ARE IN INCHES FRACTIONAL ± ANGULAR: MACH ± BEND ± TWO PLACE DECIMAL ± THREE PLACE DECIMAL ±	DRAWN CHECKED ENG APPR. MEG APPR.	NAME DATE	TITLE: SUBASSEMBLY, ELECTRICAL
INTERPRET GEOMETRIC TOLERANCING PER: MATERIAL FINISH NEXT ASSY USED ON APPLICATION	<SEE BOM> N/A DO NOT SCALE DRAWING	Q.A. COMMENTS:	SIZE DWG. NO. D INS-2947 SCALE: 1:4 WEIGHT: 72
			REV C SHEET 3 OF 3



APPENDIX V

Oilgear Pump Manual

OILGEAR TYPE "PVG" PUMPS - 048/065/075/100/130 SERVICE INSTRUCTIONS

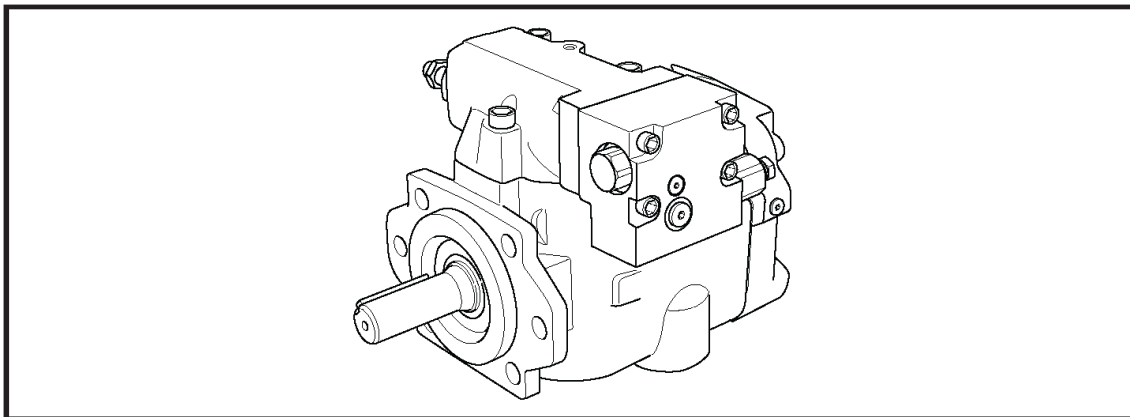

Figure 1. Typical Oilgear "PVG" Open Loop Pump

PURPOSE OF INSTRUCTIONS

These instructions will simplify the installation, operation, maintenance and troubleshooting of Oilgear type "PVG" pumps.

Become familiar with the construction, principle of operation and characteristics of your pump to help you attain satisfactory performance, reduce shut-down and increase the pump's service life. Some pumps have been modified from those described in this bulletin and other changes may be made without notice.

REFERENCE MATERIAL

Fluid Recommendations	Bulletin 90000
Contamination Evaluation Guide.....	Bulletin 90004
Filtration Recommendations	Bulletin 90007
Piping Information	Bulletin 90011

Pump Control Instructions

"P-1NN" Pressure Compensator	Data Sheet 947541
"P-1NN/F" Pressure Compensator w/Load Sense	Data Sheet 947542
"P-1NN/H" Pressure Compensator w/H.P. Limited	Data Sheet 947543
"P-1NN/G" Horsepower Limit w/Load Sense	Data Sheet 947544
"P-2 -" Dual Pressure Compensator	Data Sheet 947545
"P-A" and "P-B" Electrohydraulic Proportional Pressure Compensator	Data Sheet 947546
"P-C -" Soft Starting	Data Sheet 947547
"V-S" Electrohydraulic Servo Valve w/o Amplifier	Data Sheet 947719
"V-A" Electrohydraulic Servo Valve w/Amplifier	Data Sheet 947720

THE OILGEAR COMPANY

2300 South 51st Street
Milwaukee, Wisconsin 53219

Safety First

Read and understand this entire instruction sheet before repairing, or adjusting your Oilgear product.

Those who use and maintain this equipment must be thoroughly trained and familiar with the product. If incorrectly used or maintained, this product and its equipment can cause severe injury.

SAFETY SYMBOLS

The following signal words are used in this instruction sheet to identify areas of concern where your safety may be involved. Carefully read the text and observe any instructions provided to ensure your safety.

DANGER

THIS SIGNAL WORD INDICATES AN IMMEDIATELY HAZARDOUS SITUATION WHICH, IF NOT AVOIDED, WILL RESULT IN DEATH OR SERIOUS INJURY.

WARNING

This signal word indicates a potentially hazardous situation which, if not avoided, could result in death or serious injury.

CAUTION

This signal word indicates that a potentially hazardous situation exists which, if not avoided, may result in damage to equipment or minor personal injury.

NOTE

While not directly relevant to the topic being discussed, the NOTE is used to emphasize information provided, or provide additional information which may be of benefit.

WARNING

This service information is designed for the maintenance of your Oilgear product. It contains the information on the correct procedures determined by Oilgear for the safe manner of servicing. Always keep this instruction sheet in a location where it is readily available for the persons who use and maintain the product. Additional copies of this instruction sheet are available through the Oilgear Company. (Contact phone number.) Or visit our website: www.oilgear.com. Please contact us if you have any questions regarding the information in this instruction bulletin.

NOTE

The cleanliness of working on this pump or the hydraulic system is extremely important to the safety and reliability of the pump and the system. Always make sure the fittings are clean on the outside before removing them from their connections, are capped and plugged when removed and placed in a clean rag or container until they are reinstalled.

WARNING

Some service operations may require special tools or equipment. If you require information on these items, please contact Oilgear before attempting these repairs and service operations.

WARNING

Read, understand, and follow the safety guidelines, dangers, and warnings contained in this instruction sheet to promote reliable operation and prevent serious personal injury.

WARNING

DO NOT attempt to service this machinery in an environment where safety regulations are not established and in place.

WARNING

DO NOT operate the hydraulic system if a leak is present. Serious injury may result.

WARNING

Hydraulic systems operate under very high pressure. Hydraulic fluid escaping from a pressurized system can penetrate unprotected body tissue. DO NOT inspect for hydraulic leaks with bare hands or other exposed body parts. As a minimum, wear leather gloves prior to inspecting for leaks and use cardboard or wood. If leaks are present, relieve pressure and allow system to cool prior to servicing. If injured by escaping hydraulic oil, contact a physician immediately. Serious complications may arise if not treated immediately. If you have questions regarding inspecting for hydraulic leaks, please contact Oilgear prior to servicing.

⚠ WARNING

Hydraulic hoses and tubing must be inspected on a daily basis for leaks, cuts, abrasions, damage and improper clearance along any mounting frame for hidden damage before the unit is put into service. Replace damaged hoses or hoses you suspect are damaged before the system is returned to service! Hoses must be replaced every two years. Failure to properly inspect and maintain the system may result in serious injury.

⚠ WARNING

Hydraulic systems are hot. DO NOT TOUCH! Serious personal injury may result from hot oil. When you have completed working on the hydraulic system, thoroughly clean any spilled oil from the equipment. Do not spill any hydraulic fluids on the ground. Clean any hydraulic fluids from your skin as soon as you have completed maintenance and repairs. Dispose of used oil and system filters as required by law.

⚠ WARNING

Use correct hoses, fittings, and adapters with the correct SAE rating when replacing hoses to prevent possible serious injury. Always replace hoses, fittings, and adapters with replacements that have a proper, suitable, working pressure rating. Replacement hoses must be of the correct length and must comply with the hose manufacturer's and Oilgear's installation guidelines and recommendations.

⚠ WARNING

Hydraulic hoses have the SAE ratings marked on the hose to assist you in selecting the correct hose. The same manufacturer must supply any replacement hydraulic hoses and fitting assemblies. As an example: Brand "X" hose and brand "Y" fitting will not normally be compatible. No "Twist" is allowed in the hydraulic hoses. "Twist" may result in premature hose failure. This can cause serious injury. Please contact Oilgear for assistance when required.

⚠ WARNING

Hydraulic cylinders can be holding a function in a certain position when the pump is OFF. An example of this is a function being held in the lift or partial lift position by the cylinders. If a hydraulic line is removed or the hydraulic circuits or controls are being worked on, gravity may allow the function being held in position to drop. All workers and personnel must remain clear of these areas when working on or operating the hydraulic system. Block and secure all devices and functions which apply before beginning work or operation. Failure to comply with this can result in serious injury or death.

⚠ WARNING

Any hydraulic pipe which is replaced must conform to SAE J1065 specifications. If incorrect hydraulic pipe is installed, the hydraulic system may fail, causing serious injury. Damaged or leaking fittings, pipes or hoses must be replaced before the system is returned to service.

⚠ WARNING

DO NOT heat hydraulic pipe. The carbon content of this steel tube is such that if heated for bending, and either water or air quenched, the pipe may lose its ductility and thereby be subject to failure under high pressure or hydraulic chock conditions. Serious injury can result. Damaged or leaking pipes must be replaced before the system is returned to service. Please contact Oilgear if you require assistance or have questions.

⚠ WARNING

All hydraulic pressure must be relieved from the hydraulic system prior to removing any components from the system. To relieve the hydraulic pressure from the hydraulic system, turn off the motor and operate the control panel with the key in the ON position. Failure to comply can result in serious injury. If you have any questions concerning relieving the hydraulic pressure from the system, please contact Oilgear.

WARNING

Hydraulic components can be heavy. Use caution while lifting these components. Serious personal injury can be avoided with proper handling of the components.

WARNING

Please contact Oilgear if you require assistance, when performing hydraulic test procedures, use the proper hydraulic gauges. Installing an incorrect test gauge could result in serious injury if the gauge fails. Use properly rated hydraulic hoses to allow the test gauge to be read away from moving parts and functions.

WARNING

Increasing hydraulic pressure beyond the recommendations may result in serious damage to the pump and system or serious personal injury and may void the Oilgear Warranty. If you have questions concerning hydraulic pressures or testing procedures, please contact Oilgear before attempting the test procedures or making adjustments.

WARNING

An Oilgear pump must not be modified in any way without authorization from Oilgear. Modifications may not comply with safety standards, including ANSI safety standards, and may result in serious personal injury. Please contact Oilgear if you require assistance.

WARNING

DO NOT enter under hydraulic supported equipment unless they are fully supported or blocked. Failure to follow this procedure can result in serious injury or death.

WARNING

Any Oilgear pump safety decals must be replaced anytime they are damaged, missing, or cannot be read clearly. Failure to have proper decals in place can result in serious injury or death. (If you require safety decals, please contact Oilgear for replacement safety decals, at no charge.)

WARNING

Be sure everyone is clear of the area around the hydraulic system before operating after servicing. Remain attentive at all times when operating to check your work until you are completely sure it is safe to return to service. Failure to heed this warning may result in serious personal injury or death.

WARNING

Wear the proper protective clothing when operating, servicing or maintaining the hydraulic system or the Oilgear pump. Wear the correct protective gear, safety glasses, gloves, and safety shoes. Serious injury can result without proper protective gear.

WARNING

Make sure to keep hands and feet and other parts of your body clear of revolving or moving parts. Failure to comply can cause serious injury.

WARNING

DO NOT wear watches, rings, or jewelry while working with electrical and mechanical equipment. These items can be hazardous and can cause serious and painful injuries if they come into contact with electrical wires, moving parts, or hydraulic equipment.

PREPARATION AND INSTALLATION

MOUNTING

Pump Without Reservoir - The pump can be mounted in any position. But, the recommended mounting position is with the drive shaft on a horizontal plane and the case drain port 1 on the top side. Secure the pump to a rigid mounting surface. Refer to the referenced Oilgear Piping Information Bulletin 90011.

Pump With Reservoir - These pumps are usually fully piped and equipped. It may be necessary to connect to a super-charge circuit when used. Mount reservoir on level foundation with the reservoir bottom at least six inches above floor level to facilitate fluid changes.

PIPING AND FITTINGS

Refer to the referenced Oilgear Piping Information Bulletin 90011 and individual circuit diagram before connecting the pump to the system. Inlet velocity must not exceed 5 fps (1,5 mps). Inlet should be unrestricted and have a minimum of fittings.

NOTE

DO NOT use an inlet strainer.

Arrange line from "case drain" so the case remains full of fluid (non-siphoning). Case pressure must be less than 25 psi (1,7 bar). For higher case pressures and the special shaft seals required, contact our Customer Service. Each drain line must be a separate line, unrestricted, full sized and connected directly to the reservoir below the lowest fluid level. Make provisions for opening this line without draining (siphoning) reservoir.

WARNING

Running the pump in NEUTRAL position (zero delivery) for extended periods without a supercharge circuit can damage the pump. The system and pump must be protected against overloads by separate high pressure relief valves. Install bleed valve(s) at the highest point(s) in system.

POWER

Power is required in proportion to volume and pressure used. Motor size recommendations for specific applications can be obtained from The Oilgear Company. Standard low starting torque motors are suitable for most applications.

CAUTION

DO NOT start or stop unit under load unless system is approved by Oilgear. It may be necessary to provide delivery bypass in some circuits.

DRIVE

Verify rotation direction plate on the pump's housing. Clockwise pumps must be driven clockwise and counterclockwise pumps must be driven counterclockwise. Use direct drive coupling. Size and install coupling per manufacturer's instructions.

CAUTION

DO NOT drive the coupling onto the pump drive shaft. If it is too tight, it may be necessary to heat coupling for installation. Refer to manufacturer's instructions.

Misalignment of pump shaft to driver's shaft should not exceed 0.005 inches (0,13 mm) Total Indicator Readout (TIR) in any plane.

FILTRATION

Keep the fluid clean at all times to ensure long life from your hydraulic system. Refer to the referenced Oilgear Filtration Recommendations bulletin 90007 and Oilgear Contamination Evaluation Guide Bulletin 90004. Oilgear recommends use of a filter in the pressure or return line. Replace filter element(s) when the filter condition indicator reaches change area at normal fluid temperature. Drain and thoroughly clean filter case. Use replacement element(s) of same beta 10 ratio (normally a ratio of 4 with hydraulic oils).

FLUID COOLING

When the pump is operated continuously at the rated pressure or frequently at peak load, auxiliary cooling of the fluid may be necessary. Fluid temperature should not exceed limits specified in the referenced Oilgear Fluid Recommendations Bulletin 90000.

AIR BREATHER

On most installations, an air breather is mounted on top of fluid reservoir. It is important for the breather to be the adequate size to allow air flow in and out of reservoir as fluid level changes. Keep the breather case filled to the "fluid level" mark. About once every six months, remove cover, wash screen in solvent and allow screen to dry, clean and refill case to level mark and install screen. Refer to the manufacturer's recommendations.

FLUID, FILLING AND STARTING RECOMMENDATIONS

Refer to instruction plate on the unit, reservoir, machine and/or reference, Fluid Recommendations bulletin. Fire resistant fluids and phosphate ester fluids can be used in accordance with fluid manufacturer's recommendations.

1. Pump all fluid into reservoir through a clean (beta 10 ratio of 4 or more) filter. Fill reservoir to, but not above, "high level" mark on the sight gauge.
2. **Remove case drain line and fill pump case with hydraulic fluid.**
3. Turn drive shaft a few times by hand with a spanner wrench to make sure parts rotate.

Unit	048/065/075/100/130
Approximate Torque to turn drive shaft	9-24 ft•lb (12-32 N•m)

Table 1. Torque to Turn Shaft

With pump under "no load" or with pump control at NEUTRAL:

4. Turn drive unit ON and OFF several times before allowing pump to reach full speed. The system can usually be filled by running the pump and operating the control.
5. The fluid level in the reservoir should decrease. Stop the pump. **DO NOT** allow the fluid level to go beyond the "low level." If the level reaches "low level" mark, add fluid and repeat step.

NOTE

With differential (cylinder) systems, the fluid must not be above "high level" when the ram is retracted or below "low level" when extended. Bleed air from the system by loosening connections or opening petcocks at the highest point in the system. Close connections or petcocks tightly when solid stream of fluid appears.

CONSTRUCTION

See Figures 2, 8 and 9.

1. A drive shaft (301) runs through the center line of pump housing (001) and valve plate (401) with the pump cylinder barrel (101) splined to it.
2. A bearing (306) supports the outboard end of the drive shaft and a bushing supports the inboard end. (The bushing is part of valve plate assembly.)
3. The pump cylinder barrel is carried in a polymerous (journal type) cylinder bearing (202).
4. The valve plate (401) has two crescent shaped ports.
5. The pumping piston/shoe assemblies (102) in the cylinder barrel are held against a swashblock (201) by a shoe retainer (104).
6. The shoe retainer is held in position by the fulcrum ball (103) which is forced outward by the shoe retainer spring (105).
7. The spring acts against the pump cylinder barrel, forcing it against the valve plate while also forcing the piston shoes against the swashblock.
8. The semi-cylindrical shaped swashblock limits the piston stroke and can be swiveled in arc shaped saddle bearings (204).
9. The swashblock is swiveled by a control (included in referenced material). Refer to PRINCIPLE OF OPERATION.

SPECIFICATIONS

NOTE Refer to reference material, pump control material and individual application circuit for exceptions.

Unit	THEORETICAL MAXIMUM DISPLACEMENT		RATED CONTINUOUS PRESSURE		MAXIMUM PRESSURE		FLOW RATE at 1800 rpm rated continuous pressure and 14.7 psia (bar abs) inlet condition		MAXIMUM SPEED	POWER INPUT at rated continuous pressure & 1800 rpm	
	in 3/rev	ml/rev	psi	bar	psi	bar	gpm	l/mi	rpm	hp	kw
PVG 048	2.93	48,0	5000	344,8	5800	400,0	21.1	79,9	2700	73	54,5
PVG 065	3.98	65,0	5000	344,8	5800	400,0	28.8	108,9	2700	100	74,6
PVG 075	4.60	75,4	3750	258,6	4250	293,1	33.3	126,0	2700	89	66,4
PVG 100	6.00	98,3	5000	344,8	5800	400,0	42.4	160,5	2400	150	111,9
PVG 130	7.94	130,2	3750	258,6	4250	293,1	57.6	218,0	2400	150	111,9

Case pressure should be less than 25 psi (1,7 bar). For higher pressure, consult factory.
Higher speeds available - consult factory.

Table 2. Nominal Performance Data with 150--300 SSU viscosity fluids.

Unit	Length		Width		Height		Weight		Face Mounting
	inches	mm	inches	mm	inches	mm	lbs.	kg	
PVG 048, 065, 075	12.0	303,0	6.9	174,5	6.3	160,4	68*	31	SAE "B" 2 and 4 bolt
PVG 100, 130	13.0	330,5	8.4	212,9	7.3	185,7	110*	50	SAE "C" 2 bolt

All dimensions (without controls) are approximate. For detailed dimensions, contact your Oilgear Representative.

* Weight with P Control and rear port valve plate

Table 3. Nominal Dimensions and Weights without controls.

Refer to installation drawings for more detailed dimensions and port configurations.

TROUBLESHOOTING		
PROBLEM	CAUSES	REMEDY
Unresponsive or Sluggish Control	Low control input (pilot) pressure for "R" and "V" volume type controls only.	Refer to referenced control instruction material.
	Swashblock saddle bearings (204) worn or damaged.	Inspect bearings. Replace.
Insufficient Pump Volume	Delivery limited by faulty control	Refer to appropriate control instruction material.
	Obstructed suction circuit or insufficient supercharge volume.	Inspect for obstruction and verify supercharge.
	Insufficient drive motor speed.	Refer to appropriate power material.
	Worn or grooved cylinder barrel (101) and/or valve plate (401) mating surfaces.	Inspect components. Replace.
	Worn piston/shoe assemblies (102) or piston bores in cylinder (101).	
Worn or damaged piston shoe or swashblock (201).		
Irregular or Unsteady Operation	Faulty control.	Inspect components. Replace.
	Fluid level in reservoir is low or supercharge is insufficient.	Verify fluid level and/or supercharge.
	Air entering hydraulic system.	Inspect system for leak.
	Worn axial piston pump.	Inspect components. Replace.
Loss of Pressure	Faulty output circuit components (cylinder, motors, valves or other related components).	Inspect components. Replace.
	Worn piston pump.	Inspect components. Replace.
	Worn or grooved cylinder barrel (101) and/or valve plate (401) mating surfaces.	
	Worn piston/shoe assemblies (102) or piston bores in cylinder.	
Faulty output circuit components.		
Excessive or High Peak Pressure	Faulty output circuit components.	Check the relief valves.
Excessive Noise	Pump stopped or started incorrectly under load.	Verify operation procedure of pump.
	Low fluid level in reservoir or insufficient supercharge causing cavitation.	Verify fluid level and/or supercharge.
	Air entering hydraulic system.	Inspect system for leak.
	Fluid too cold or viscosity too high.	Verify fluid temperature and/or type.
	Suction line problem i.e.; obstructions in line, line too long, line diameter too small or too many bends and/or loops in line.	Inspect line and for obstruction.
	Broken or worn piston/shoe assembly (102).	Inspect components. Replace.
Pump rotating in wrong direction.	Inspect operation direction of pump.	
Excessive Heating	Operating pump above rated or peak pressure.	Verify pump limitations.
	Low fluid level in reservoir or insufficient supercharge.	Verify fluid level and/or supercharge.
	Air entering hydraulic system.	Inspect system for leak.
	Worn piston pump.	Inspect components. Replace.
	Worn or grooved cylinder barrel (101) and/or valve plate (401) mating surfaces.	
	Faulty output circuit components (continuous blowing relief valves or "slip" through valves, cylinder or other components).	
Insufficient cooling provision or clogged coolers.	Inspect for obstruction.	

PRINCIPLE OF OPERATION

The illustrations show the pump driven clockwise (right hand) from the top (plan) view.

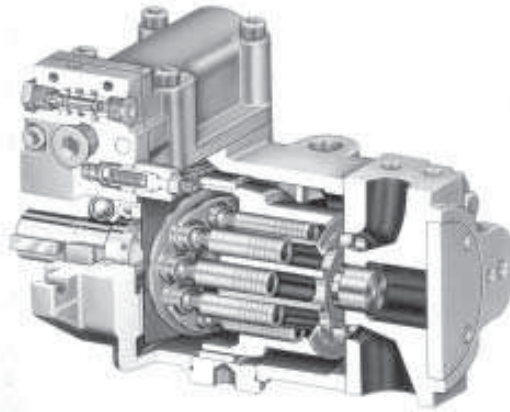

Figure 2. Cut-a-way of a Typical "PVG" Pump (92011R)

Position B, Pump During Full Delivery FROM PORT B - Figure 3

Rotating the drive shaft (301) clockwise turns the splined cylinder, which contains the pumping pistons (102). When the cylinder rotates, the pistons move in and out within their bores as the shoes ride against the angled (C) swashblock (201).

As the cylinder rotates, the individual piston bores are connected, alternately, to the crescent shaped upper (port A) and lower (port B) in the valve plate. While connected to the upper side (suction) port A, each piston moves outward **OUT**, drawing fluid from port A into the piston bore until its outermost stroke (D) is reached. At this point, the piston bore passes from the upper crescent port A to the lower crescent port B.

While rotating across the lower crescent, each piston moves across the angled swashblock face and then each piston is forced inward **IN**. Each piston then displaces fluid through the lower crescent to port B until its innermost stroke (D) is reached. At this point, the piston bore passes from the lower to the upper crescent again and the cycle is repeated.

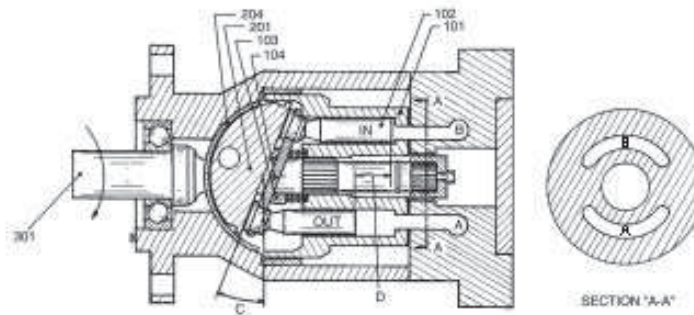

Figure 3. Position B, Pump During Full Delivery From Port B

Position B/2, Pump During One Half Delivery FROM PORT B - Figure 4

This illustration shows that the angle (E) of the swashblock determines the length of the piston stroke (F), (the difference between outermost and innermost position) which determines the amount of delivery from the pump. In this case, the stroke angle (E) is one-half of the stroke, which means the piston stroke is one-half and the pump delivery is one-half.

Position N, Pump In Neutral, No Stroke, No Delivery - Figure 5

Neutral position results when the control centers the swashblock. The swashblock angle (G) is now zero and swashblock face is parallel to the cylinder face. There is no inward or outward motion of the pump pistons as piston shoes rotate around the swashblock face. With no inward and outward motion or no stroke (H), **NEUTRAL** no fluid is being displaced from the piston bores to the crescents in the valve plate and there is no delivery from pump ports.

NOTE Illustration reference numbers match the part item number in the parts list.

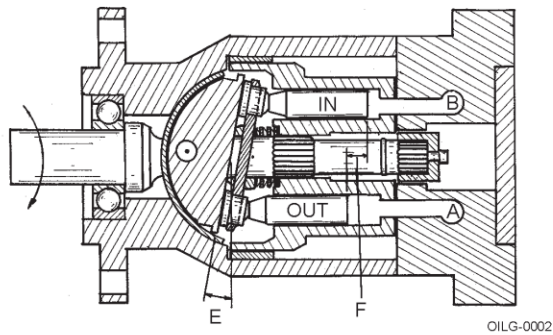

Figure 4. Position B/2, Pump During One Half Delivery From Port B

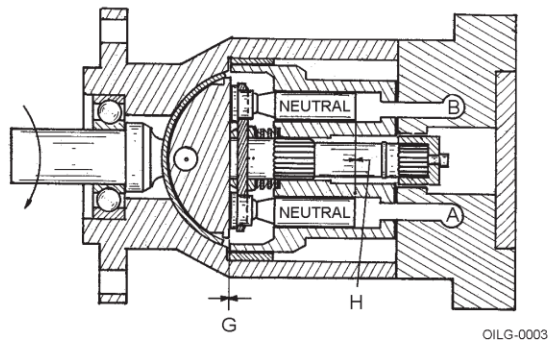

Figure 5. Position N, Pump In Neutral, No Stroke, No Delivery

Refer to **SPECIFICATIONS**

TESTING AND ADJUSTING

WARNING

Shut the pump OFF and release pressure from the system before disassembling components. Failure to comply with these instructions could result in personal injury or death. Blocking the pressure line between the pump and the system (or pump) high pressure relief valve will result in damage and could result in serious personal injury.

PISTON PUMP

To check for a worn piston pump, make a leak measurement test from the case drain while the pump is under pressure. After the unit is warm, either install a flow meter in the drain line or have the flow from the drain line directed into a large container or reservoir. The pump case must remain full of fluid during this test.

CAUTION

DO NOT run a pump on stroke against a blocked output unless it is protected by a high pressure relief valve and then run no longer than necessary to check slip. Limit discharge to prevent dropping reservoir fluid below low level.

With an accurate high pressure gauge in the pressure line, start the pump and stall (or block) output device to raise system pressure to maximum (as set by system relief valve). Read the measurement on the flow meter or time and measure the case drain flow used to fill a known size container and calculate the flow rate in terms of cubic inches per minute (cipm). The leakage should conform to **Table 4**.

NOTE *Additional leakage indicates wear, but does not become critical until it impairs performance.*

DISASSEMBLY

NOTE

The cleanliness of working on this pump or the hydraulic system is extremely important to the safety and reliability of the pump and the system.

When disassembling or assembling the pump, choose a clean, dry, dust and sand free area where no traces of abrasive particles are in the air which can damage the pump and system. DO NOT work near welding, sandblasting, grinding benches or similar conditions.

Always make sure the fittings are clean on the outside before removing them from their connections. Make sure they are capped and plugged when removed. Place them on a clean surface and in a clean rag or container until they are reinstalled. When cleaning parts which have been disassembled, it is important to use CLEAN cleaning solvents and parts are allowed to dry. All tools and gauges should be clean prior to working with the system and use new, CLEAN lint free rags to handle and dry parts.

WARNING

DO NOT attempt to remove or install any components or assembly while the pump and system is running. Always stop the pump, shut OFF the power and release pressure from the system before servicing or testing. Be sure provisions have been made so the case drain line can be disconnected from the unit without causing the line to drain (siphon) the reservoir.

(continued)

DISASSEMBLY (Continued)

1. Disconnect case drain line from port 1 or 1A.
2. Drain pump case through the remaining (port 1 or 1A) on the bottom of case. If plugs are inaccessible, it may be necessary to remove the pump from the mounting and drive motor before draining it.
3. After removing the pump from the mounting and before disassembly, cap or plug all ports and clean the outside of unit thoroughly to prevent dust from entering the system. See Figures 9 and 10.

NOTE

Depending on what part or parts are to be inspected, it may not be necessary to completely take apart all assemblies.

CONTROL GROUP

Refer to the reference material for the information which applies to the control your pump is equipped with. Some force is required to remove the control housing.

1. Remove socket head cap screws.
2. Lift the control group assembly, with control pin, straight up from the top of the pump assembly. The control pin may or may not remain in the swashblock (201).
3. Remove control gasket and O-rings from the pump housing.

VALVE PLATE GROUP

If another pump is coupled to thru-shaft pumps, it will be necessary to remove coupling half before removing valve plate.

1. Block the pump on a bench with the drive shaft facing down.
2. Remove the valve plate (401) by removing four hex head cap screws (403) and lifting it straight up.
3. Remove valve plate gasket (411) and O-ring (404).

Unit - Size		Case Slip at Full Stroke and Indicated Pressure						
		500 psi	1000 psi	2000 psi	3000 psi	3750 psi	4000 psi	5000 psi
048, 065, 075	cipm	130	195	455	760	1070	N/A	N/A
	lpm	2,1	3,2	7,5	12,5	17,5	N/A	N/A
100	cipm	190	250	400	600		900	1200
	lpm	3,1	4,1	6,5	9,8		14,7	19,7
130	cipm	300	400	600	1000	1400	N/A	N/A
	lpm	4,9	6,6	9,8	16,4	22,9	N/A	N/A

**Table 4. NOMINAL CASE SLIP versus High Pressure at 1800 rpm
(Viscosities of 90-110 SSU)**

ROTATING GROUP

⚠ WARNING

The rotating group is heavy. Be careful not to damage cylinder wear surface which mates against the valve plate, bearing diameters or piston shoes. Use proper lifting techniques and assistance from others to prevent personal injury.

On thru-shaft pumps, the tailshaft bushing assembly (307, 308, 309) or a coupling will have to be removed (a "jacking" screw can be used) before the rotating group can be disassembled.

1. Place the pump in a horizontal position.
2. Remove the rotating group by turning shaft (301) slowly, while pulling the cylinder barrel (101) from the housing.
3. Identify (number) each pump piston shoe assembly (102) and its respective bore in the cylinder barrel (101) and shoe retainer (104) for easy reassembly.
4. See Figure 6. Lift out shoe retainer (104) with pistons (102) and remove the fulcrum ball (103) and shoe retainer spring (105).

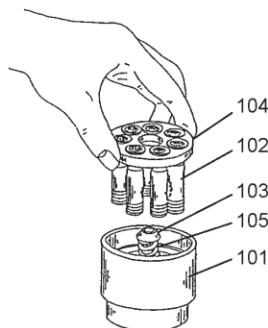

OILG-0004

Figure 6. Rotating Group Disassembly (5V-12015-L).

5. Remove retaining ring (208) and pull the hydrodynamic bearing (202) and roll pins, if necessary, (205) from the housing. Note the position of roll pin (205) inside of case.

DRIVE SHAFT GROUP

1. Remove the drive key (303), if used and the drive shaft bearing retainer ring (305).
2. Grasp outboard end of drive shaft (301) and pull it out of the pump housing.
3. Remove the shaft seal retainer (302) and shaft seal (007) from the housing only if necessary.

SWASHBLOCK GROUP

On 100/130 remove guide plate (203) and (206) first. Reach inside the case and remove the swashblock (201) and saddle bearings (204).

INSPECTION

Clean all parts thoroughly and allow them to dry. Inspect all seals and O-rings for hardening, cracking or deterioration. Replace if necessary or if you suspect damage. Check all locating pins for damage and springs for cracking or signs of cracking or signs of wear.

⚠ WARNING

Wear proper protective gear when using solvents or compressed air, servicing or maintaining the hydraulic system or the Oilgear pump. Wear correct protective gear, safety glasses, gloves, and safety shoes. Serious injury can result without proper protective gear.

CONTROL GROUP

Refer to the reference material on pump controls. Be sure to carefully check the control pin for cracks and/or signs of fatigue. Check fit of the pin in the swashblock. It should be a slip-fit without side-play. Replace if necessary or if you suspect damage.

VALVE PLATE GROUP

Inspect the valveplate (401) surface which mates with the cylinder barrel (101) for excessive wear or scoring. Remove minor defects by lightly stoning the surface with a hard stone which is flat to within 0.001 inches (0,03 mm).

NOTE *Be sure to stone lightly. Any excessive stoning will remove the hardened surface. If wear or damage is extensive, replace the valve plate.*

ROTATING GROUP

Inspect cylinder barrel (101) piston bores and the face which mate with the valve plate for wear and scoring. Remove minor defects on the face by lightly stoning or lapping the surface.

Inspect the cylinder bearing (202) for damage and replace if necessary. Check all piston and shoe assemblies (102) to be sure they ride properly on the swashblock.

NOTE *Be sure to stone lightly. Any excessive stoning will remove the hardened surface. If wear or damage is extensive and defects cannot be removed, replace the cylinder barrel.*

See **Figure 7**. Check each shoe face for nicks and scratches, and the shoe for smooth pivot action on the piston.

NOTE *If one or more piston/shoe assembly needs to be replaced, replace all the piston/shoe assemblies. When installing new piston/shoe assemblies or the rotating group, make sure the pistons move freely in their respective bores.*

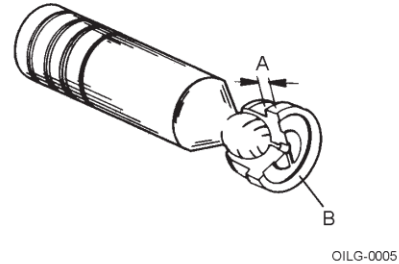

Figure 7. Piston and Shoe Inspection (5V-12015-L)

- (A) All shoes must be equal within 0.001 inches (0,025 mm) at this dimension.
- (B) All shoe faces must be free of nicks.

NOTE *End play should not exceed 0.003 inches (0,076 mm) when new or 0.006 inches (0,152 mm) when worn.*

SWASHBLOCK GROUP

Inspect the swashblock (201) for wear and scoring. If defects are minor, stone the swashblock lightly. If damage is extensive, replace the swashblock.

Check the small hole in the face of the swashblock. The hole provides "porting" for the hydrostatic balance fluid of the piston/shoe assembly to be channeled through the swashblock to the face of the saddle bearing, providing pressure lubrication.

Compare the saddle bearing (204) thickness in a worn area to thickness in an unworn area. Replace saddle bearings if the difference is greater than 0.015 inches (0,4 mm).

Check the mating surface of swashblock for cracks or excessive wear. The swashblock movement in the saddle bearings must be smooth. Replace if necessary.

NOTE *Be sure to stone lightly. Any excessive stoning will remove the hardened surface. If wear or damage is extensive and defects cannot be removed, replace if necessary or if you suspect them of being bad.*

DRIVE SHAFT GROUP

Check:

- the shaft seal (007) for deterioration or cracks. Replace if necessary (press-out).
- the shaft bearing (306) for galling, pitting, binding or roughness.
- the rear shaft bushing in valve plate.
- the shaft and its splines for wear. Replace any parts necessary.

ASSEMBLY

See Figures 8, 9 and 10. Follow the disassembly procedures in reverse for re-assembling the pump.

During assembly, install new gaskets, seals and O-rings. Apply a thin film of CLEAN grease or hydraulic fluid to sealing components to ease assembly. If a new rotating group is used, lubricate thoroughly with CLEAN hydraulic fluid. Apply fluid generously to all wear surfaces.

SWASHBLOCK GROUP

If removed,

1. Press shaft seal (007) into front of pump housing.
2. Place housing on a bench with the mounting flange side down.
3. Press the two roll pins (207) (if they are replaced or removed) into the pump housing so the pins extend 0.050 to 0.065 inches (1,3 to 1,6 mm) from the case.
4. Grease the back side of each saddle bearing (204) and place on the pin to locate the bearings in the pump case. Make sure the pins do not protrude.
5. PVG 100 and 130, the swashblock is inserted from the valve plate end. PVG 048, 065 and 075, the swashblock is inserted through the control mounting face. Insert swashblock (201) into the pump housing. Once in place, be sure the swashblock swivels in the saddle bearings. With new bearings, swiveling may be stiff and not always smooth. PVG 110, 130; assemble (203) and (206).

6. Make sure the roll pin (205) is inserted into the cylinder bearing (202). Position the cylinder bearing so the pin is located nearest the control facing the outboard end of the drive shaft (301). The bearing should be positioned with "scarf" cuts (PVG 130 only) positioned top and bottom and with the pin (205) located on top of internal cast boss. The bearing should fit into place with a little difficulty and be square to the axis of the pump.
7. Tap bearing into place if necessary using extreme care not to damage the bearing.
8. Insert retaining ring (208) to hold bearing in place.

DRIVE SHAFT GROUP

1. Place the housing on its side with the axis horizontal.
2. Install the seal retainer (302).
3. Lubricate the shaft seal (007) and shaft.
4. Insert the drive shaft (301) and bearing assembly into the housing.
5. Lock in place with the drive shaft bearing retainer ring (305).

ROTATING GROUP

See Figure 6.

1. Place the cylinder barrel (101), wear surface down, on a clean cloth.
2. Place the shoe retainer spring (105) in the center of the barrel with the fulcrum ball (103) on top of it.
3. Insert the identified pistons (102) into their corresponding identified holes of the shoe retainer (104). As a unit, fit the pistons into their corresponding, identified bores in the cylinder barrel. **DO NOT FORCE.** If everything is aligned properly, the pistons will fit smoothly.

⚠ WARNING

The rotating group weight is heavy. Be careful not to damage cylinder wear surface which mates against the valve plate, bearing diameters or piston shoes. Use proper lifting techniques and assistance from others to prevent personal injury.

The rotating group can now be carefully installed over the tail of the drive shaft (301) and into the pump housing (001).

NOTE When installing the rotating group, support the weight of the cylinder barrel (101), as cylinder spline is passed over the tailshaft, to avoid scratching or damage.

4. Push cylinder forward until the cylinder spline reaches the drive shaft spline and rotate slightly to engage shaft splines. Continue to slide cylinder forward until it encounters the cylinder bearing (202). Lifting the tailshaft slightly helps the cylinder (101) and the cylinder bearing (202) engagement. Continue pushing the cylinder forward until the piston shoes contact the swashblock, the back of the cylinder should be located approximately 0.4 inches (10,2 mm) outside the back of the pump housing.

NOTE On thru-shaft pumps without another pump or device connected to them, slide assembly onto the shaft (301) and secure cap assembly (307, 309) in with socket head shoulder screw (308).

VALVE PLATE GROUP

1. Place the pump housing on a bench with the open end facing up.
2. Install new O-ring (411) and gasket (407) on the housing.
3. Position the valve plate (401) on pins (005) and housing. Make sure the tail end of shaft engages the bushing.
4. Hand-tighten the hex head cap screw (403) closest to O-ring (404) first, then alternately tighten the other cap screws. On thru-shaft units connected to another pump or device, install coupling (half).

Refer to **PREPARATION** and **INSTALLATION** when pump is ready to be returned to service.

PVG Assembly Torques		
Item no.	Pump	
	048/065/075	100/130
002	100 ft-lb	100 ft-lb
004	37 ft-lb	37 ft-lb
206	N/A	87 in-lb
308	57 in-lb	57 in-lb
403	100 ft-lb	100 ft-lb
408	45 in-lb	45 in-lb
409	45 in-lb	45 in-lb
410	120 in-lb	120 in-lb
503 cover plate	28 ft-lb	28 ft-lb
503 SAE A or A-A adapt	15 ft-lb	15 ft-lb
503 SAE B adapter	37 ft-lb	37 ft-lb
503 SAE C adapter	N/A	74 ft-lb
507	28 ft-lb	28 ft-lb

PARTS LIST

Parts used in these assemblies are per Oilgear specifications. Use only Oilgear parts to ensure compatibility with assembly requirements. When

ordering replacement parts, be sure to include pump type and serial number, bulletin number and item number. Specify type of hydraulic fluid to assure seal and packing compatibility.

Item	Qty.	Description
HOUSING ASSEMBLY GROUP		
001	1	Housing, Pump
003	1	Nameplate, Identification
004	1	Plug
005	4	Pin, Roll - 048, 065, 130
005	2	Pin, Roll - 100, 130
006	2	Pin, Roll - 100, 130
007	1	Seal, Shaft
008	2	Screw
010	1	Seal, O-ring
ROTARY ASSEMBLY GROUP		
101	1	Barrel, Cylinder
102	9	Assembly, Piston/Shoe
103	1	Ball, Fulcrum
104	1	Retainer, Shoe
105	1	Spring, Shoe Retainer
SWASHBLOCK ASSEMBLY GROUP		
201	1	Swashblock
202	1	Bearing, Cylinder
203	1	Guide Plate - 100, 130 only
204	2	Bearing, Saddle
205	1	Pin, Roll (2 for PVG 130)
206	2	Screw - 100, 130 only
207	2	Pin, Roll
208	1	Ring, Retainer

PARTS LIST drawings on pages 19, 20 and 30.

Parts are common between pumps. Only the differences are shown.

O-ring Sizes ARP 568 Uniform Size number with Durometer

Item Number	Pump	
	048, 065, 075	100, 130
010	916 - 70	916 - 70
404	012 - 90	013 - 90
405	902 - 90	902 - 90
406	903 - 90	903 - 90
407	904 - 90	904 - 90
413	138 - 70	138 - 70

Item	Qty.	Description
		DRIVE SHAFT ASSEMBLY GROUP
301	1	Drive Shaft
302	1	Retainer, Seal Side
303	1	Key, Drive Shaft (keyed shafts only)
304	1	Ring, Retainer, External
305	1	Ring, Retainer, Internal
306	1	Bearing, Front
307	1	Bushing (used on thru-shaft w/ cover plate)
308	1	Screw (used on thru-shaft w/ cover plate)
309	1	Roll Pin (used on thru-shaft w/ cover plate)
		VALVE PLATE ASSEMBLY GROUP
401	1	Valve Plate w/bearing
403	4	Screw, Socket Head Cap (048, 065, 075)
403	4	Screw, Hex Head Cap (100, 130)
404	1	Seal, O-ring
405	1	Seal, O-ring
406	1	Seal, O-ring (not required for all versions)
407	1	Seal, O-ring
408	1	Plug, #2 HP
409	1	Plug, #3 HP (not required for all versions)
410	1	Plug, #4 HP
411	1	Gasket, Valve Plate

PARTS LIST drawings on pages 19, 20 and 30.

Parts are common between pumps. Only the differences are shown.

Parts used in this assembly are per Oilgear specifications. Use only Oilgear parts to ensure the compatibility with the assembly requirements. When ordering replacement parts, be sure to include pump type and serial number, bulletin number and item number. To assure seal and packing compatibility, specify type of hydraulic fluid.

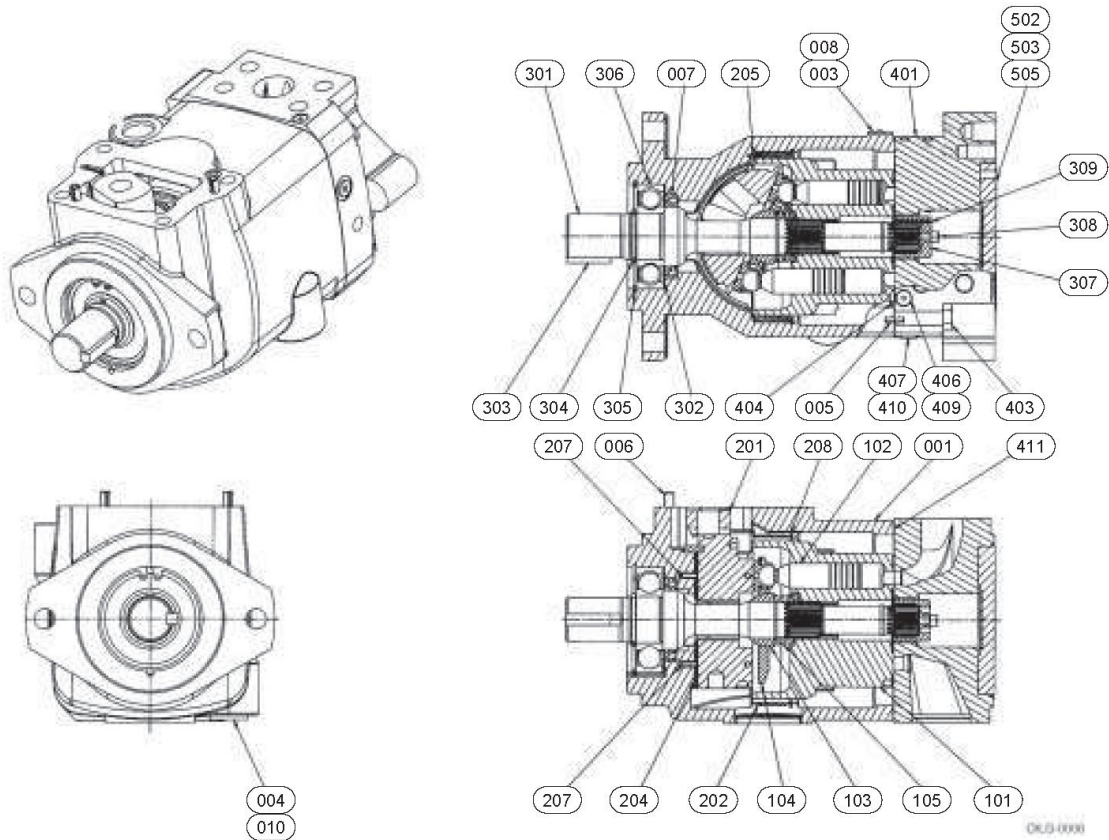
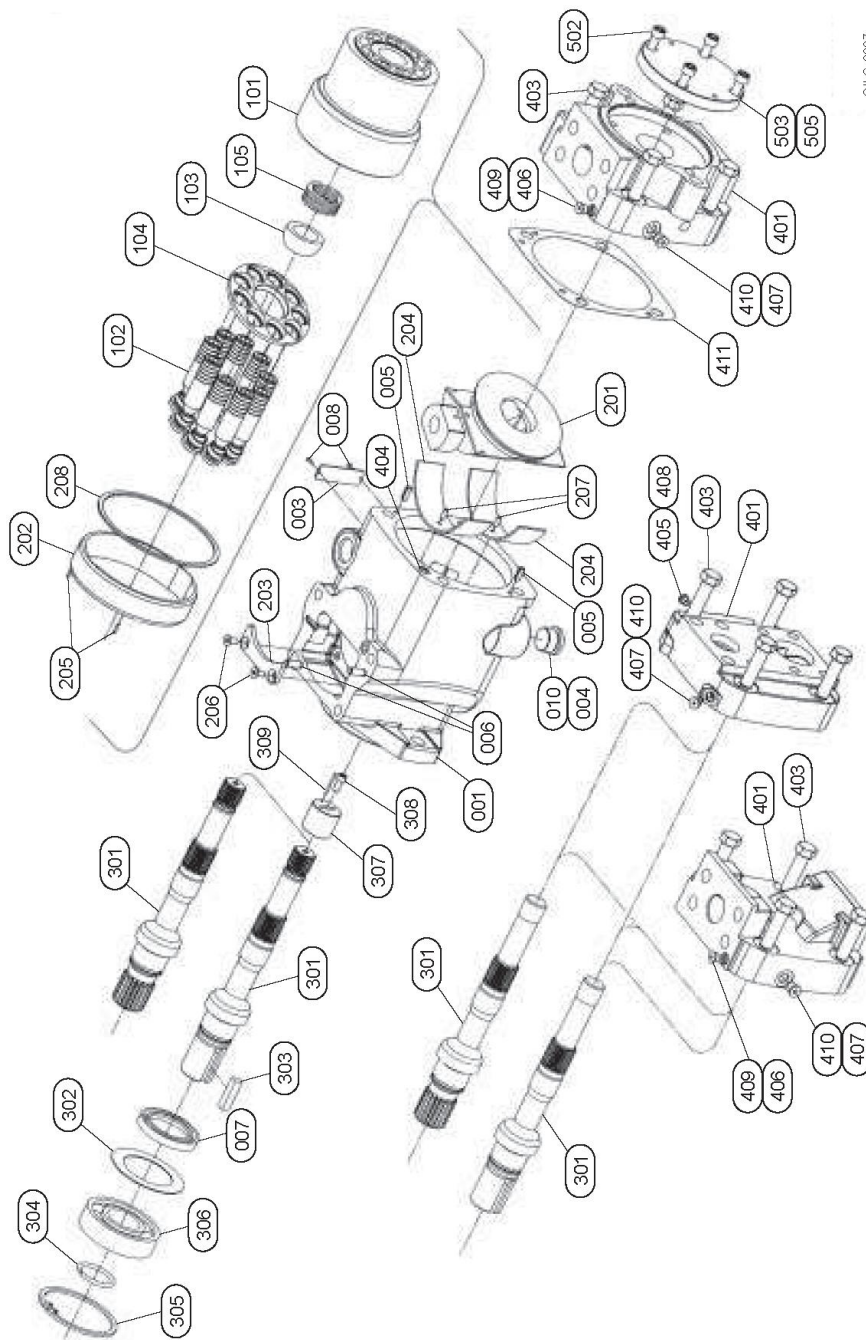

Figure 8. Cross section and plan view parts drawing, PVG 100/130 (516246 sheet 1 of 3).

NOTE

Pins shown out of position. Hydrobearing (202) to be assembled with scarf cuts positioned top and bottom with pins (205), which locate on top of internal cast boss (PVG 130 only).



OILG-0007

Figure 9. Exploded parts drawing, PVG 100/130 (516246 sheet 2 of 3).

SERVICE KITS

PVG B Pump Service Kits

SERVICE KIT Drawings on pages 30 and 31.

Document Number: 517105-SK

Revision: 0 (10-6-03)

Sheet 1 of 3

Description	Kit No.	Design Series	Items Included (quantity is 1 unless noted)
Housing Kits			
Viton Seals	L517105-604	All(A)	001,002,003,004,005(4),007,008(2),010,011,207(2)
Nitrile Seals	L517105-603	All(A)	
EPR Seals	L517105-602	All(A)	
Shaft & Bearing Kits			
Viton or Nitrile seals			
1" Dia. Keyed (Code Y) Std	L517104-301	All	301B,302,303,304,305,306
13T, 16/32 Spline (Code K) Std	L517104-305	All	301C,302,304,305,306
15T, 16/32 Spline (Code S) Std	L517104-302	All	301A,302,304,305,306
1" Dia. Keyed (Code Y) T-S	L517104-303	All	301D,302,303,304,305,306
13T, 16/32 Spline (Code K) T-S	L517104-306	All	301E,302,304,305,306
15T, 16/32 Spline (Code S) T-S	L517104-304	All	301E,302,304,305,306
EPR Seals			
1" Dia. Keyed (Code Y) Std	L517104-313	All	301B,302,303,304,305,306
13T, 16/32 Spline (Code K) Std	L517104-315	All	301C,302,304,305,306
15T, 16/32 Spline (Code S) Std	L517104-317	All	301A,302,304,305,306
1" Dia. Keyed (Code Y) T-S	L517104-312	All	301D,302,303,304,305,306
13T, 16/32 Spline (Code K) T-S	L517104-314	All	301E,302,304,305,306
15T, 16/32 Spline (Code S) T-S	L517104-316	All	301E,302,304,305,306
Swashblock			
All	516597-050	B2(B)	201
Saddle Bearing			
Standard	L517105-220	All	204(2)
High Temp	L517105-221	All	
Hydrodynamic Bearing Kit			
All	L517105-210	All	202,205,208
Rotating Group			
PVG-048/065	L517104-103	B2(B)	101,102(9),103,104,105
PVG-075	L517105-103	B2(B)	
Piston & Shoe Sub-Assembly			
PVG-048/065	K407905-R65	B2(B)	102(9)
PVG-075	K407905-A75	B2(B)	
Shoe Retainer & Fulcrum Ball			
PVG-048/065	L319221-365	All	103,104
PVG-075	L319221-375	All	

PVG B Pump Service Kits

Reference: 517105 Ass'y Drwg

Document Number: 517105-SK

Revision: 0 (10-6-03)

Sheet 2 of 3

Description	Kit No.	Design Series	Items Included (quantity is 1 unless noted)
Valve Plate Kits			
PVG-048/065 Rear Port LH			
Viton Seals	L517104-401	All	401A,403(4),404,405,406,407,408,409,410,411
Nitrile Seals	L517104-411	All	
EPR Seals	L517104-408	All	
PVG-048/065 Rear Port RH			
Viton Seals	L517104-402	All	401B,403(4),404,405,406,407,408,409,410,411
Nitrile Seals	L517104-412	All	
EPR Seals	L517104-413	All	
PVG-048/065 Side Port LH			
Viton Seals	L517104-405	All	401C,403(4),404,405,406,407,408,409,410,411
Nitrile Seals	L517104-414	All	
EPR Seals	L517104-415	All	
PVG-048/065 Side Port RH			
Viton Seals	L517104-406	All	401D,403(4),404,405,406,407,408,409,410,411
Nitrile Seals	L517104-416	All	
EPR Seals	L517104-417	All	
PVG-048/065 Side Port, Thru-Shaft LH			
Viton Seals	L517104-403	All	401E,403(4),404,405(2),407(2),408(2),410(2),411
Nitrile Seals	L517104-418	All	
EPR Seals	L517104-410	All	
PVG-048/065 Side Port, Thru-Shaft RH			
Viton Seals	L517104-404	All	401F,403(4),404,405(2),406,407,408(2),409,410,411
Nitrile Seals	L517104-419	All	
EPR Seals	L517104-420	All	
PVG-075 Rear Port LH			
Viton Seals	L517105-401	All	401A,403(4),404,405,406,407,408,409,410,411
Nitrile Seals	L517105-417	All	
EPR Seals	L517105-410	All	
PVG-075 Rear Port RH			
Viton Seals	L517105-402	All	401B,403(4),404,405,406,407,408,409,410,411
Nitrile Seals	L517105-418	All	
EPR Seals	L517105-411	All	
PVG-075 Side Port LH			
Viton Seals	L517105-405	All	401C,403(4),404,405,406,407,408,409,410,411
Nitrile Seals	L517105-419	All	
EPR Seals	L517105-414	All	
PVG-075 Side Port RH			
Viton Seals	L517105-406	All	401D,403(4),404,405,406,407,408,409,410,411
Nitrile Seals	L517105-420	All	
EPR Seals	L517105-415	All	
PVG-075 Side Port, Thru-Shaft LH			
Viton Seals	L517105-403	All	401E,403(4),404,405(2),407(2),408(2),410(2),411
Nitrile Seals	L517105-409	All	
EPR Seals	L517105-412	All	
PVG-075 Side Port, Thru-Shaft RH			
Viton Seals	L517105-404	All	401F,403(4),404,405(2),406,407,408(2),409,410,411
Nitrile Seals	L517105-416	All	
EPR Seals	L517105-413	All	

PVG B Pump Service Kits

Reference: 517105 Ass'y Drwg

Document Number: 517105-SK

Revision: 0 (10-6-03)

Sheet 3 of 3

Description	Kit No.	Design Series	Items Included (quantity is 1 unless noted)
Basic Seal Kit			
Viton Seals	K517105-B11	All	007,010,011,404,405(2),406,407(2),411 Control 313,330,341(2)
Nitrile Seals	K517105-B12	All	
EPR Seals	K517105-B13	All	
Seal Kits for Options			
Standard Cover Plate			
Viton Seals	238270-138	All	505
Nitrile Seals	233370-138	All	
EPR Seals	242080-138	All	
SAE B Adaptor			
Viton Seals	L250667-017	All	505,506
Nitrile Seals	L250667-016	All	
EPR Seals	L250667-018	All	
SAE A Adaptor			
Viton Seals	L250667-014	All	505,506
Nitrile Seals	L250667-013	All	
EPR Seals	L250667-015	All	
SAE A-A Adaptor			
Viton Seals	L250667-019	All	505,508
Nitrile Seals	L250667-020	All	
EPR Seals	L250667-021	All	
Shaft Seal			
Viton Seals	51155-5	All	007
Nitrile Seals	51155-7	All	
EPR Seals	L51155-3RP	All	
Cover Plate Kit			
Viton Seals	L319076-101	All	307,308,309,502,503(4),505
Nitrile Seals	L319076-105	All	
EPR Seals	L319076-115	All	
Rear Shaft Cover Kit			
All	L319263	All	307,308,309
SAE B Adaptor/Coupling Kit			
Viton Seals	L319076-100	All	501,502,503(2),504(2),505,506
Nitrile Seals	L319076-107	All	
EPR Seals	L319076-108	All	
SAE A Adaptor/Coupling Kit 9 tooth			
Viton Seals	L319076-103	All	501,502,503(2),504(2),505,506,507(4)
Nitrile Seals	L319076-109	All	
EPR Seals	L319076-110	All	
SAE A Adaptor/Coupling Kit 11 tooth			
Viton Seals	L319076-106	All	501,502,503(2),504(2),505,506,507(4)
Nitrile Seals	L319076-111	All	
EPR Seals	L319076-112	All	
SAE A-A Adaptor/Coupling Kit			
Viton Seals	L319076-104	All	501,502,503(2),504(2),505,507(4),508
Nitrile Seals	L319076-113	All	
EPR Seals	L319076-114	All	
Name Tag & Screws			
All	L50921	All	003,008(2)

Std = Rear ported or Side ported w/o thru-shaft, T-S = Side ported w/ thru-shaft

(A) Pump cases are interchangeable

- A1 series has #12 SAE threaded case drain connection
- B1 and B2 have #16 SAE threaded case drain connection

(B) Swashblock and Rotating group/piston and shoe assembly must have matching design series

- B2 parts must all be same design series
- A1, B1 parts can be intermixed between series

PVG C Pump Service Kits

Document Number: 516246-SK

Revision: 0 (10-6-03)

Sheet 1 of 6

Description	Kit No.	Design Series	Items Included (quantity is 1 unless noted)	
Housing Kits				
USA				
Viton Seals	L516275-601	All(A)	001,002,003,004,005(2),006(2),007,008(2),010,011,207(2)	
Nitrile Seals	L516275-603	All(A)		
EPR Seals	L516275-602	All(A)		
Metric				
Viton Seals	L516679-601	All(A)		
Nitrile Seals	L516679-602	All(A)		
EPR Seals	L516679-605	All(A)		
Shaft & Bearing Kits				
Viton or Nitrile seals				
1.50" Dia. Keyed (Code Z) Short	L516175-301	All(B)	301D,302,303,304,305,306	
1.50" Dia. Keyed (Code Y) Std	L516175-307	All(B)	301D,302,303,304,305,306	
14T, 12/24 Spline (Code K) Std	L516175-305	All	301E,302,304,305,306	
17T, 12/24 Spline (Code S) Std	L516175-302	All	301E,302,304,305,306	
1.50" Dia. Keyed (Code Z) T-S Short	L516175-303	All(B)	301A,302,303,304,305,306	
1.50" Dia. Keyed (Code Y) T-S	L516175-308	All(B)	301A,302,303,304,305,306	
14T, 12/24 Spline (Code K) T-S	L516175-306	All	301B,302,304,305,306	
17T, 12/24 Spline (Code S) T-S	L516175-304	All	301B,302,304,305,306	
EPR Seals				
1.50" Dia. Keyed (Code Z) Short	L516175-328	All(B)	301D,302,303,304,305,306	
1.50" Dia. Keyed (Code Y) Std	L516175-322	All(B)	301D,302,303,304,305,306	
14T, 12/24 Spline (Code K) Std	L516175-324	All	301E,302,304,305,306	
17T, 12/24 Spline (Code S) Std	L516175-326	All	301E,302,304,305,306	
1.50" Dia. Keyed (Code Z) T-S Short	L516175-327	All(B)	301A,302,303,304,305,306	
1.50" Dia. Keyed (Code Y) T-S	L516175-321	All(B)	301A,302,303,304,305,306	
14T, 12/24 Spline (Code K) T-S	L516175-323	All	301B,302,304,305,306	
17T, 12/24 Spline (Code S) T-S	L516175-325	All	301B,302,304,305,306	
Swashblock				
All	515794	All	201	
Guide Plate Assembly				
USA	L516175-225	All	203,206(2)	
Metric	L516679-225	All		
Saddle Bearing				
Standard	L516175-220	All	204(2)	
High Temp	L516175-221	All		
Hydrodynamic Bearing Kit				
PVG-100	L516175-210	All	202,205,208	
PVG-130	L516275-210	All		
Rotating Group				
PVG-100	L516175-101	All	101,102(9),103,104,105	
PVG-130	L516275-102	C2(C)		

PVG C Pump Service Kits

Document Number: 516246-SK

Revision: 0 (10-6-03)

Sheet 2 of 6

Description	Kit No.	Design Series	Items Included (quantity is 1 unless noted)
Piston & Shoe Sub-Assembly			
PVG-100	K407812-800	All	102(9)
PVG-130	K407837-800	All	
Shoe Retainer & Fulcrum Ball			
PVG-100	L318925-001	All	103, 104
PVG-130	L318926	All	
Valve Plate Kits			
USA			
PVG-100 Rear Port LH			
Viton Seals	L516175-401	All	401D,403(4),404,405,407,408,410,411
Nitrile Seals	L516175-413	All	
EPR Seals	L516175-407	All	
PVG-100 Rear Port RH			
Viton Seals	L516175-402	All	401D,403(4),404,405,406,407,408,409,410,411
Nitrile Seals	L516175-414	All	
EPR Seals	L516175-408	All	
PVG-100 Side Port LH			
Viton Seals	L516175-405	All	401E,403(4),404,405,406,407,408,409,410,411
Nitrile Seals	L516175-417	All	
EPR Seals	L516175-411	All	
PVG-100 Side Port RH			
Viton Seals	L516175-406	All	401E,403(4),404,405,406,407,408,409,410,411
Nitrile Seals	L516175-418	All	
EPR Seals	L516175-412	All	
PVG-100 Side Port, Thru-Shaft LH			
Viton Seals	L516175-403	All	401A,403(4),404,405(2),406,407,408(2),409,410,411
Nitrile Seals	L516175-415	All	
EPR Seals	L516175-409	All	
PVG-100 Side Port, Thru-Shaft RH			
Viton Seals	L516175-404	All	401A,403(4),404,405(2),406,407,408(2),409,410,411
Nitrile Seals	L516175-416	All	
EPR Seals	L516175-410	All	
PVG-130 Rear Port LH			
Viton Seals	L516275-401	C2(C)	401D,403(4),404,405,407,408,410,411
Nitrile Seals	L516275-425	C2(C)	
EPR Seals	L516275-407	C2(C)	
PVG-130 Rear Port RH			
Viton Seals	L516275-402	C2(C)	401D+D161,403(4),404,405,406,407,408,409,410,411
Nitrile Seals	L516275-428	C2(C)	
EPR Seals	L516275-408	C2(C)	
PVG-130 Side Port LH			
Viton Seals	L516275-405	C2(C)	401E,403(4),404,405,406,407,408,409,410,411
Nitrile Seals	L516275-417	C2(C)	

PVG C Pump Service Kits

Document Number: 516246-SK

Revision: 0 (10-6-03)

Sheet 3 of 6

Description	Kit No.	Design Series	Items Included (quantity is 1 unless noted)
PVG-130 Side Port RH			
Viton Seals	L516275-424	C2(C)	401E,403(4),404,405,406,407,408,409,410,411
Nitrile Seals	L516275-418	C2(C)	
EPR Seals	L516275-412	C2(C)	
PVG-130 Side Port, Thru-Shaft LH			
Viton Seals	L516275-403	C2(C)	401A,403(4),404,405(2),406,407,408(2),409,410,411
Nitrile Seals	L516275-415	C2(C)	
EPR Seals	L516275-409	C2(C)	
PVG-130 Side Port, Thru-Shaft RH			401A,403(4),404,405(2),406,407,408(2),409,410,411
Viton Seals	L516275-404	C2(C)	
Nitrile Seals	L516275-416	C2(C)	
EPR Seals	L516275-410	C2(C)	
Metric			
PVG-100 Rear Port LH			
Viton Seals	L516678-401	All	401D,403(4),404,405,407,408,410,411
Nitrile Seals	L516678-407	All	
EPR Seals	L516678-408	All	
PVG-100 Rear Port RH			
Viton Seals	L516678-402	All	401D,403(4),404,405,406,407,408,409,410,411
Nitrile Seals	L516678-409	All	
EPR Seals	L516678-410	All	
PVG-100 Side Port LH			
Viton Seals	L516678-405	All	401E,403(4),404,405,406,407,408,409,410,411
Nitrile Seals	L516678-411	All	
EPR Seals	L516678-412	All	
PVG-100 Side Port RH			
Viton Seals	L516678-406	All	401E,403(4),404,405,406,407,408,409,410,411
Nitrile Seals	L516678-413	All	
EPR Seals	L516678-414	All	
PVG-100 Side Port, Thru-Shaft LH			
Viton Seals	L516678-403	All	401A,403(4),404,405(2),406,407,408(2),409,410,411
Nitrile Seals	L516678-415	All	
EPR Seals	L516678-416	All	
PVG-100 Side Port, Thru-Shaft RH			
Viton Seals	L516678-404	All	401A,403(4),404,405(2),406,407,408(2),409,410,411
Nitrile Seals	L516678-417	All	
EPR Seals	L516678-418	All	
PVG-130 Rear Port LH			
Viton Seals	L516679-425	C2(C)	401D,403(4),404,405,407,408,410,411
Nitrile Seals	L516679-427	C2(C)	
EPR Seals	L516679-429	C2(C)	
PVG-130 Rear Port RH			
Viton Seals	L516679-420	C2(C)	401D+D161,403(4),404,405,406,407,408,409,410,411
Nitrile Seals	L516679-414	C2(C)	
EPR Seals	L516679-430	C2(C)	
PVG-130 Side Port LH			
Viton Seals	L516679-407	C2(C)	401E,403(4),404,405,406,407,408,409,410,411
Nitrile Seals	L516679-419	C2(C)	
EPR Seals	L516679-431	C2(C)	

PVG C Pump Service Kits

Document Number: 516246-SK

Revision: 0 (10-6-03)

Sheet 4 of 6

Description	Kit No.	Design Series	Items Included (quantity is 1 unless noted)	
PVG-130 Side Port RH				
Viton Seals	L516679-428	C2(C)	401E,403(4),404,405,406,407,408,409,410,411	
Nitrile Seals	L516679-432	C2(C)		
EPR Seals	L516679-433	C2(C)		
PVG-130 Side Port, Thru-Shaft LH				
Viton Seals	L516679-421	C2(C)	401A,403(4),404,405(2),406,407,408(2),409,410,411	
Nitrile Seals	L516679-434	C2(C)		
EPR Seals	L516679-435	C2(C)		
PVG-130 Side Port, Thru-Shaft RH				
Viton Seals	L516679-404	C2(C)	401A,403(4),404,405(2),406,407,408(2),409,410,411	
Nitrile Seals	L516679-436	C2(C)		
EPR Seals	L516679-437	C2(C)		
Basic Seal Kit				
USA				
Viton Seals	K516175-C11	All	007,010,011,404,405(2),406,407(2),411 Control 330,313	
Nitrile Seals	K516175-C12	All		
EPR Seals	K516175-C13	All		
Metric				
Viton Seals	K516678-C11	All		
Nitrile Seals	K516678-C12	All		
EPR Seals	K516678-C13	All		
Seal Kits for Options				
Standard Cover Plate				
Viton Seals	238270-138	All	505	
Nitrile Seals	233370-138	All		
EPR Seals	242080-138	All		
SAE C Adaptor				
Viton Seals	238270-049	All	505	
Nitrile Seals	233370-049	All		
EPR Seals	242080-049	All		
SAE B Adaptor				
Viton Seals	L250667-017	All	505,506	
Nitrile Seals	L250667-016	All		
EPR Seals	L250667-018	All		
SAE A Adaptor				
Viton Seals	L250667-014	All	505,506	
Nitrile Seals	L250667-013	All		
EPR Seals	L250667-015	All		
SAE A-A Adaptor				
Viton Seals	L250667-019	All	505,508	
Nitrile Seals	L250667-020	All		
EPR Seals	L250667-021	All		
Shaft Seal				
Viton Seals	51156-5	All	007	
Nitrile Seals	51156-7	All		
EPR Seals	L51156-3RP	All		

PVG C Pump Service Kits

Document Number: 516246-SK

Revision: 0 (10-6-03)

Sheet 5 of 6

Description	Kit No.	Design Series	Items Included (quantity is 1 unless noted)
Cover Plate Kit			
USA			307,308,309,502,503(4),505
Viton Seals	L319076-001	All	
Nitrile Seals	L319076-013	All	
EPR Seals	L319076-301	All	
Metric			
Viton Seals	L319076-M01	All	
Nitrile Seals	L319076-M07	All	
EPR Seals	L319076-M08	All	
Rear Shaft Cover Kit			
All	L319066-006	All	307,308,309
SAE C Adaptor/Coupling Kit			
USA			501,503(2),504(2),505
Viton Seals	L319076	All	
Nitrile Seals	L319076-008	All	
EPR Seals	L319076-300	All	
Metric			
Viton Seals	L319076-M00	All	
Nitrile Seals	L319076-M09	All	
EPR Seals	L319076-M10	All	
SAE B-B Adaptor/Coupling Kit			
USA			501,502,503(2),504(2),505,506
Viton Seals	L319076-005	All	
Nitrile Seals	L319076-012	All	
EPR Seals	L319076-014	All	
Metric			
Viton Seals	L319076-M05	All	
Nitrile Seals	L319076-M11	All	
EPR Seals	L319076-M12	All	
SAE B Adaptor/Coupling Kit			
USA			501,502,503(2),504(2),505,506
Viton Seals	L319076-002	All	
Nitrile Seals	L319076-007	All	
EPR Seals	L319076-302	All	
Metric			
Viton Seals	L319076-M02	All	
Nitrile Seals	L319076-M13	All	
EPR Seals	L319076-M14	All	
SAE A Adaptor/Coupling Kit 9 tooth			
USA			501,502,503(2),504(2),505,506,507(4)
Viton Seals	L319076-003	All	
Nitrile Seals	L319076-011	All	
EPR Seals	L319076-303	All	
Metric			
Viton Seals	L319076-M03	All	
Nitrile Seals	L319076-M15	All	
EPR Seals	L319076-M16	All	

PVG C Pump Service Kits

Document Number: 516246-SK

Revision: 0 (10-6-03)

Sheet 6 of 6

Description	Kit No.	Design Series	Items Included (quantity is 1 unless noted)
SAE A Adaptor/Coupling Kit 11 tooth			
USA			
Viton Seals	L319076-006	All	501,502,503(2),504(2),505,506,507(4)
Nitrile Seals	L319076-015	All	
EPR Seals	L319076-016	All	
Metric			
Viton Seals	L319076-M06	All	
Nitrile Seals	L319076-M17	All	
EPR Seals	L319076-M18	All	
SAE A-A Adaptor/Coupling Kit			
USA			
Viton Seals	L319076-004	All	501,502,503(2),504(2),505,507(4),508
Nitrile Seals	L319076-017	All	
EPR Seals	L319076-018	All	
Metric			
Viton Seals	L319076-M04	All	
Nitrile Seals	L319076-M19	All	
EPR Seals	L319076-M20	All	
Name Tag & Screws			
All	L50921	All	003,008(2)

Std = Rear ported or Side ported w/o thru-shaft, T-S = Side ported w/ thru-shaft

(A) Pump cases are interchangeable

A1 series has #12 SAE threaded case drain connection

B1, C1, C2, D3, D4, E1 have #16 SAE threaded case drain connection

(B) Code "Y" shaft is length of Code "Z" shaft for Design Series "A1"

Parts are interchangeable between Design Series

(C) PVG130 Valve plate and Rotating group must be matched

A1, B1, C1 parts can be intermixed between series

C2, D3, D4, E1 parts can be intermixed between series

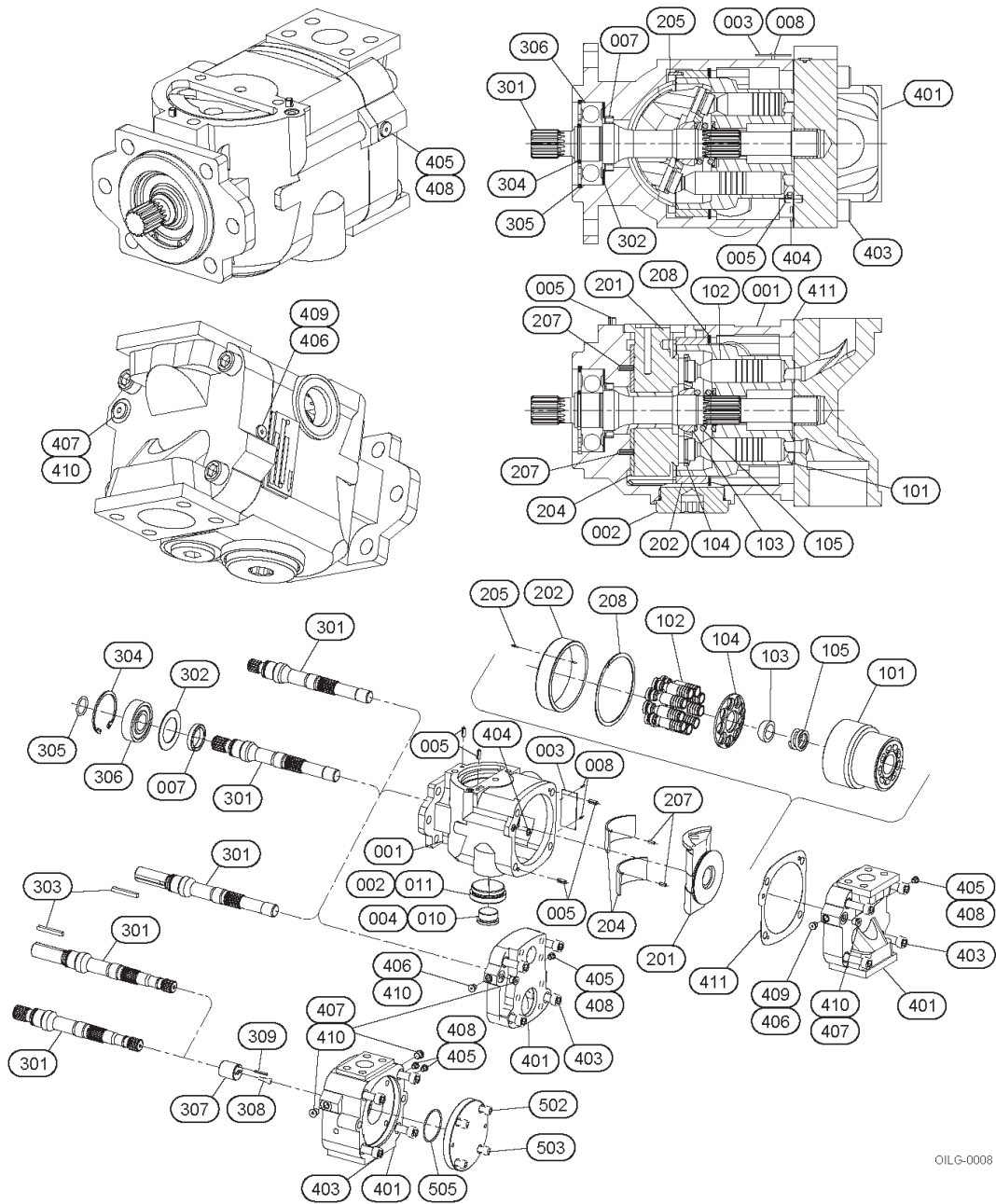

OILG-0008

Figure 10. Cross Section and Exploded Parts Drawing for PVG 048, 065 and 075 (517105 sheet 1 and 2)

NOTE Cylinder bearing (202) to be held in position with roll pin (205) which must be located in the cast side slot of housing (001).

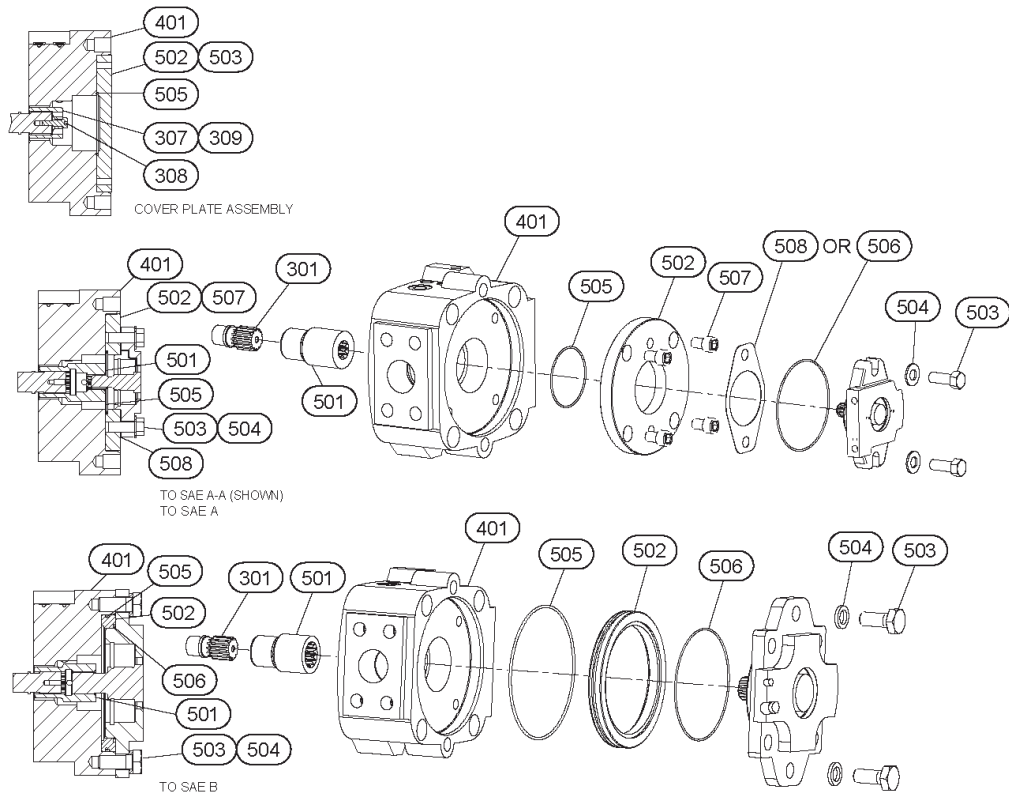

THRU-SHAFT OPTIONS OILG-0009

Available for PVG 048, 065, 075, 100 and 130
(Drawing 517105 sheet 6 and 7)

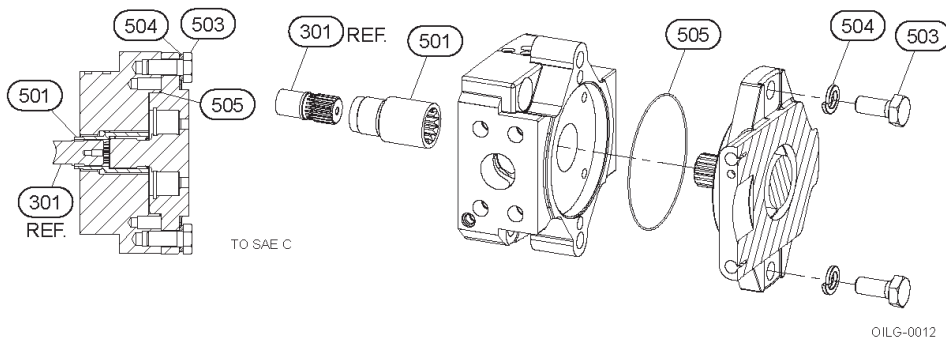

OILG-0012

Available for PVG 100 and 130
(Drawing 516246 sheet 6, 7 and 8)

Figure 11. Cross Section and Exploded Parts Drawing

AFTER SALES SERVICES

At Oilgear we build products to last. It is the nature of this type of machinery to require proper maintenance regardless of the care we put into manufacturing. Oilgear has several service programs in place to help you.

STAY-ON-STREAM SERVICE

By signing up for Oilgear's Stay-On-Steam program, you can prepare for problems before they happen. Certain field tests such as fluid testing, slip testing and electronic profile recording comparisons can be performed by our field service people or your own factory trained personnel. These tests can indicate problems before they become "down-time" difficulties.

SERVICE SCHOOLS

Oilgear conducts training to train your maintenance personnel. "General" hydraulic or electronic training is conducted at our Milwaukee, Wisconsin plant on a regular basis. "Custom" training, specifically addressing your particular hydraulic and electro-hydraulic equipment can be conducted at your facilities.

SPARE PARTS AVAILABILITY

Prepare for your future needs by stocking Oilgear original factory parts. Having the correct parts and necessary skills "in-plant" enables you to minimize "down-time." Oilgear has developed parts kits to cover likely future needs. Oilgear Field Service Technicians are also ready to assist you and your maintenance people in troubleshooting and repairing equipment.





APPENDIX VI

5711

Safety Data Sheet

MIL-PRF-5606 Hydraulic Fluid

Product Name: MOBIL AERO HFA
Revision Date: 01 Oct 2015
Page 1 of 12

SAFETY DATA SHEET

SECTION 1 PRODUCT AND COMPANY IDENTIFICATION

PRODUCT

Product Name: MOBIL AERO HFA
Product Description: Base Oil and Additives
Product Code: 201550401020, 490110-00, 970584
Intended Use: Aviation hydraulic oil

COMPANY IDENTIFICATION

Supplier: EXXON MOBIL CORPORATION
22777 Springwoods Village Parkway
Spring, TX. 77253 USA

24 Hour Health Emergency 609-737-4411
Transportation Emergency Phone 800-424-9300 or 703-527-3887 CHEMTREC
Product Technical Information 800-662-4525
MSDS Internet Address <http://www.exxon.com>, <http://www.mobil.com>

SECTION 2 HAZARDS IDENTIFICATION

This material is hazardous according to regulatory guidelines (see (M)SDS Section 15).

CLASSIFICATION:

Flammable liquid: Category 4.
Aspiration toxicant: Category 1.

LABEL:

Pictogram:



Signal Word: Danger

Hazard Statements:

H227: Combustible liquid. H304: May be fatal if swallowed and enters airways.

Precautionary Statements:

P210: Keep away from flames and hot surfaces. -- No smoking. P273: Avoid release to the environment. P280: Wear protective gloves and eye / face protection. P301 + P310: IF SWALLOWED: Immediately call a POISON CENTER or doctor/physician. P331: Do NOT induce vomiting. P370 + P378: In case of fire: Use water fog, foam, dry chemical or carbon dioxide (CO2) to extinguish. P403 + P235: Store in a well-ventilated place. Keep cool. P405: Store locked up. P501: Dispose of contents and container in accordance with local regulations.

Product Name: MOBIL AERO HFA
 Revision Date: 01 Oct 2015
 Page 2 of 12

Other hazard information:

HAZARD NOT OTHERWISE CLASSIFIED (HNOC): None as defined under 29 CFR 1910.1200.

PHYSICAL / CHEMICAL HAZARDS

Material can accumulate static charges which may cause an ignition. Material can release vapors that readily form flammable mixtures. Vapor accumulation could flash and/or explode if ignited. Combustible.

HEALTH HAZARDS

High-pressure injection under skin may cause serious damage. Excessive exposure may result in eye, skin, or respiratory irritation.

ENVIRONMENTAL HAZARDS

No significant hazards.

NFPA Hazard ID:	Health: 1	Flammability: 2	Reactivity: 0
HMIS Hazard ID:	Health: 1*	Flammability: 2	Reactivity: 0

NOTE: This material should not be used for any other purpose than the intended use in Section 1 without expert advice. Health studies have shown that chemical exposure may cause potential human health risks which may vary from person to person.

SECTION 3	COMPOSITION / INFORMATION ON INGREDIENTS
------------------	-------------------------------------------------

This material is defined as a mixture.

Hazardous Substance(s) or Complex Substance(s) required for disclosure

Name	CAS#	Concentration*	GHS Hazard Codes
2,6-DI-TERT-BUTYL-P-CRESOL	128-37-0	0.1 - < 1%	H400(M factor 1), H410(M factor 1)
DISTILLATES (PETROLEUM), HYDROTREATED LIGHT	64742-47-8	5 - < 10%	H304
HYDROTREATED LIGHT NAPHTHENIC DISTILLATE (PETROLEUM)	64742-53-6	50 - < 70%	H227, H304
HYDROTREATED MIDDLE DISTILLATE (PETROLEUM)	64742-46-7	20 - < 30%	H304
TRIPHENYL PHOSPHATE	115-86-6	0.1 - < 0.25%	H400(M factor 1), H410(M factor 1)

* All concentrations are percent by weight unless material is a gas. Gas concentrations are in percent by volume.

As per paragraph (i) of 29 CFR 1910.1200, formulation is considered a trade secret and specific chemical identity and exact percentage (concentration) of composition may have been withheld. Specific chemical identity and exact percentage composition will be provided to health professionals, employees, or designated representatives in accordance with applicable provisions of paragraph (i).

SECTION 4	FIRST AID MEASURES
------------------	---------------------------

INHALATION

Remove from further exposure. For those providing assistance, avoid exposure to yourself or others. Use adequate respiratory protection. If respiratory irritation, dizziness, nausea, or unconsciousness occurs, seek immediate medical assistance. If breathing has stopped, assist ventilation with a mechanical device or use mouth-to-mouth resuscitation.

SKIN CONTACT

Wash contact areas with soap and water. Remove contaminated clothing. Launder contaminated clothing before reuse. If product is injected into or under the skin, or into any part of the body, regardless of the appearance of the wound or its size, the individual should be evaluated immediately by a physician as a surgical emergency. Even though initial symptoms from high pressure injection may be minimal or absent, early surgical treatment within the first few hours may significantly reduce the ultimate extent of injury.

EYE CONTACT

Flush thoroughly with water. If irritation occurs, get medical assistance.

INGESTION

Seek immediate medical attention. Do not induce vomiting.

NOTE TO PHYSICIAN

If ingested, material may be aspirated into the lungs and cause chemical pneumonitis. Treat appropriately.

SECTION 5 FIRE FIGHTING MEASURES

EXTINGUISHING MEDIA

Appropriate Extinguishing Media: Use water fog, foam, dry chemical or carbon dioxide (CO₂) to extinguish flames.

Inappropriate Extinguishing Media: Straight Streams of Water

FIRE FIGHTING

Fire Fighting Instructions: Evacuate area. Prevent runoff from fire control or dilution from entering streams, sewers, or drinking water supply. Firefighters should use standard protective equipment and in enclosed spaces, self-contained breathing apparatus (SCBA). Use water spray to cool fire exposed surfaces and to protect personnel.

Unusual Fire Hazards: Combustible. Pressurized mists may form a flammable mixture.

Hazardous Combustion Products: Aldehydes, Incomplete combustion products, Oxides of carbon, Phosphorus oxides, Smoke, Fume, Sulfur oxides

FLAMMABILITY PROPERTIES

Flash Point [Method]: >82°C (180°F) [ASTM D-93]

Flammable Limits (Approximate volume % in air): LEL: 0.7 UEL: 7.0 [Estimated]

Autoignition Temperature: >225°C (437°F)

SECTION 6 ACCIDENTAL RELEASE MEASURES

NOTIFICATION PROCEDURES

In the event of a spill or accidental release, notify relevant authorities in accordance with all applicable

regulations. US regulations require reporting releases of this material to the environment which exceed the applicable reportable quantity or oil spills which could reach any waterway including intermittent dry creeks. The National Response Center can be reached at (800)424-8802.

PROTECTIVE MEASURES

Avoid contact with spilled material. Warn or evacuate occupants in surrounding and downwind areas if required due to toxicity or flammability of the material. See Section 5 for fire fighting information. See the Hazard Identification Section for Significant Hazards. See Section 4 for First Aid Advice. See Section 8 for advice on the minimum requirements for personal protective equipment. Additional protective measures may be necessary, depending on the specific circumstances and/or the expert judgment of the emergency responders.

For emergency responders: Respiratory protection: respiratory protection will be necessary only in special cases, e.g., formation of mists. Half-face or full-face respirator with filter(s) for dust/organic vapor or Self Contained Breathing Apparatus (SCBA) can be used depending on the size of spill and potential level of exposure. If the exposure cannot be completely characterized or an oxygen deficient atmosphere is possible or anticipated, SCBA is recommended. Work gloves that are resistant to hydrocarbons are recommended. Gloves made of polyvinyl acetate (PVA) are not water-resistant and are not suitable for emergency use. Chemical goggles are recommended if splashes or contact with eyes is possible. Small spills: normal antistatic work clothes are usually adequate. Large spills: full body suit of chemical resistant, antistatic material is recommended.

SPILL MANAGEMENT

Land Spill: Eliminate all ignition sources (no smoking, flares, sparks or flames in immediate area). Stop leak if you can do it without risk. All equipment used when handling the product must be grounded. Do not touch or walk through spilled material. Prevent entry into waterways, sewer, basements or confined areas. A vapor suppressing foam may be used to reduce vapors. Use clean non-sparking tools to collect absorbed material. Absorb or cover with dry earth, sand or other non-combustible material and transfer to containers. Large Spills: Water spray may reduce vapor; but may not prevent ignition in closed spaces. Recover by pumping or with suitable absorbent.

Water Spill: Stop leak if you can do it without risk. Confine the spill immediately with booms. Warn other shipping. Remove from the surface by skimming or with suitable absorbents. Seek the advice of a specialist before using dispersants.

Water spill and land spill recommendations are based on the most likely spill scenario for this material; however, geographic conditions, wind, temperature, (and in the case of a water spill) wave and current direction and speed may greatly influence the appropriate action to be taken. For this reason, local experts should be consulted. Note: Local regulations may prescribe or limit action to be taken.

ENVIRONMENTAL PRECAUTIONS

Large Spills: Dike far ahead of liquid spill for later recovery and disposal. Prevent entry into waterways, sewers, basements or confined areas.

SECTION 7	HANDLING AND STORAGE
------------------	-----------------------------

HANDLING

Avoid contact with skin. Avoid prolonged breathing of mists and heated vapor. Prevent small spills and leakage to avoid slip hazard. Material can accumulate static charges which may cause an electrical spark (ignition source). When the material is handled in bulk, an electrical spark could ignite any flammable vapors from liquids or residues that may be present (e.g., during switch-loading operations). Use proper bonding and/or ground procedures. However, bonding and grounds may not eliminate the hazard from static

accumulation. Consult local applicable standards for guidance. Additional references include American Petroleum Institute 2003 (Protection Against Ignitions Arising out of Static, Lightning and Stray Currents) or National Fire Protection Agency 77 (Recommended Practice on Static Electricity) or CENELEC CLC/TR 50404 (Electrostatics - Code of practice for the avoidance of hazards due to static electricity).

Static Accumulator: This material is a static accumulator.

STORAGE

The container choice, for example storage vessel, may effect static accumulation and dissipation. Keep container closed. Handle containers with care. Open slowly in order to control possible pressure release. Store in a cool, well-ventilated area. Storage containers should be grounded and bonded. Fixed storage containers, transfer containers and associated equipment should be grounded and bonded to prevent accumulation of static charge.

SECTION 8	EXPOSURE CONTROLS / PERSONAL PROTECTION
------------------	------------------------------------------------

EXPOSURE LIMIT VALUES

Exposure limits/standards (Note: Exposure limits are not additive)

Substance Name	Form	Limit / Standard		NOTE	Source
2,6-DI-TERT-BUTYL-P-CRESOL	Inhalable fraction and vapor	TWA	2 mg/m3	N/A	ACGIH
DISTILLATES (PETROLEUM), HYDROTREATED LIGHT [total hydrocarbon vapor]	Non-Aerosol	TWA	200 mg/m3	Skin	ACGIH
HYDROTREATED LIGHT NAPHTHENIC DISTILLATE (PETROLEUM)	Mist.	TWA	5 mg/m3	N/A	OSHA Z1
HYDROTREATED LIGHT NAPHTHENIC DISTILLATE (PETROLEUM)	Inhalable fraction.	TWA	5 mg/m3	N/A	ACGIH
HYDROTREATED LIGHT NAPHTHENIC DISTILLATE (PETROLEUM)	Mist.	TWA	5 mg/m3	N/A	ACGIH
HYDROTREATED MIDDLE DISTILLATE (PETROLEUM)	Mist.	TWA	5 mg/m3	N/A	OSHA Z1
HYDROTREATED MIDDLE DISTILLATE (PETROLEUM)	Inhalable fraction.	TWA	5 mg/m3	N/A	ACGIH
TRIPHENYL PHOSPHATE		TWA	3 mg/m3	N/A	OSHA Z1
TRIPHENYL PHOSPHATE		TWA	3 mg/m3	N/A	ACGIH

Exposure limits/standards for materials that can be formed when handling this product: When mists/aerosols can occur the following are recommended: 5 mg/m³ - ACGIH TLV (inhalable fraction), 5 mg/m³ - OSHA PEL.

NOTE: Limits/standards shown for guidance only. Follow applicable regulations.

No biological limits allocated.

ENGINEERING CONTROLS

The level of protection and types of controls necessary will vary depending upon potential exposure conditions.

Control measures to consider:

Use explosion-proof ventilation equipment to stay below exposure limits.

PERSONAL PROTECTION

Personal protective equipment selections vary based on potential exposure conditions such as applications, handling practices, concentration and ventilation. Information on the selection of protective equipment for use with this material, as provided below, is based upon intended, normal usage.

Respiratory Protection: If engineering controls do not maintain airborne contaminant concentrations at a level which is adequate to protect worker health, an approved respirator may be appropriate. Respirator selection, use, and maintenance must be in accordance with regulatory requirements, if applicable. Types of respirators to be considered for this material include:

No special requirements under ordinary conditions of use and with adequate ventilation.

For high airborne concentrations, use an approved supplied-air respirator, operated in positive pressure mode. Supplied air respirators with an escape bottle may be appropriate when oxygen levels are inadequate, gas/vapor warning properties are poor, or if air purifying filter capacity/rating may be exceeded.

Hand Protection: Any specific glove information provided is based on published literature and glove manufacturer data. Glove suitability and breakthrough time will differ depending on the specific use conditions. Contact the glove manufacturer for specific advice on glove selection and breakthrough times for your use conditions. Inspect and replace worn or damaged gloves. The types of gloves to be considered for this material include:

If prolonged or repeated contact is likely, chemical resistant gloves are recommended. If contact with forearms is likely, wear gauntlet style gloves.

Eye Protection: If contact is likely, safety glasses with side shields are recommended.

Skin and Body Protection: Any specific clothing information provided is based on published literature or manufacturer data. The types of clothing to be considered for this material include:

If prolonged or repeated contact is likely, chemical, and oil resistant clothing is recommended.

Specific Hygiene Measures: Always observe good personal hygiene measures, such as washing after handling the material and before eating, drinking, and/or smoking. Routinely wash work clothing and protective equipment to remove contaminants. Discard contaminated clothing and footwear that cannot be cleaned. Practice good housekeeping.

ENVIRONMENTAL CONTROLS

Comply with applicable environmental regulations limiting discharge to air, water and soil. Protect the environment by applying appropriate control measures to prevent or limit emissions.

SECTION 9

PHYSICAL AND CHEMICAL PROPERTIES

Note: Physical and chemical properties are provided for safety, health and environmental considerations only and may not fully represent product specifications. Contact the Supplier for additional information.

GENERAL INFORMATION

Physical State: Liquid

Color: Red

Product Name: MOBIL AERO HFA
 Revision Date: 01 Oct 2015
 Page 7 of 12

Odor: Characteristic
Odor Threshold: N/D

IMPORTANT HEALTH, SAFETY, AND ENVIRONMENTAL INFORMATION

Relative Density (at 15 °C): 0.88
Flammability (Solid, Gas): N/A
Flash Point [Method]: >82°C (180°F) [ASTM D-93]
Flammable Limits (Approximate volume % in air): LEL: 0.7 UEL: 7.0 [Estimated]
Autoignition Temperature: >225°C (437°F)
Boiling Point / Range: N/D
Decomposition Temperature: N/D
Vapor Density (Air = 1): N/D
Vapor Pressure: [N/D at 20 °C]
Evaporation Rate (n-butyl acetate = 1): N/D
pH: N/A
Log Pow (n-Octanol/Water Partition Coefficient): N/D
Solubility in Water: Negligible
Viscosity: 13.8 cSt (13.8 mm2/sec) at 40 °C | 5.1 cSt (5.1 mm2/sec) at 100°C [ASTM D 445]
Oxidizing Properties: See Hazards Identification Section.

OTHER INFORMATION

Freezing Point: N/D
Melting Point: N/A
Pour Point: -60°C (-76°F) [ASTM D97]
DMSO Extract (mineral oil only), IP-346: < 3 %wt

SECTION 10 STABILITY AND REACTIVITY

REACTIVITY: See sub-sections below.

STABILITY: Material is stable under normal conditions.

CONDITIONS TO AVOID: Open flames and high energy ignition sources.

MATERIALS TO AVOID: Strong oxidizers

HAZARDOUS DECOMPOSITION PRODUCTS: Material does not decompose at ambient temperatures.

POSSIBILITY OF HAZARDOUS REACTIONS: Hazardous polymerization will not occur.

SECTION 11 TOXICOLOGICAL INFORMATION

INFORMATION ON TOXICOLOGICAL EFFECTS

Hazard Class	Conclusion / Remarks
Inhalation	
Acute Toxicity: No end point data for material.	Minimally Toxic. Based on assessment of the components.
Irritation: No end point data for material.	Elevated temperatures or mechanical action may form vapors, mist, or fumes which may be irritating to the eyes, nose, throat, or lungs.

Product Name: MOBIL AERO HFA
 Revision Date: 01 Oct 2015
 Page 8 of 12

Ingestion	
Acute Toxicity: No end point data for material.	Minimally Toxic. Based on assessment of the components.
Skin	
Acute Toxicity: No end point data for material.	Minimally Toxic. Based on assessment of the components.
Skin Corrosion/Irritation: No end point data for material.	May dry the skin leading to discomfort and dermatitis. Based on assessment of the components.
Eye	
Serious Eye Damage/Irritation: No end point data for material.	May cause mild, short-lasting discomfort to eyes. Based on assessment of the components.
Sensitization	
Respiratory Sensitization: No end point data for material.	Not expected to be a respiratory sensitizer.
Skin Sensitization: No end point data for material.	Not expected to be a skin sensitizer. Based on assessment of the components.
Aspiration: Data available.	May be fatal if swallowed and enters airways. Based on physico-chemical properties of the material.
Germ Cell Mutagenicity: No end point data for material.	Not expected to be a germ cell mutagen. Based on assessment of the components.
Carcinogenicity: No end point data for material.	Not expected to cause cancer. Based on assessment of the components.
Reproductive Toxicity: No end point data for material.	Not expected to be a reproductive toxicant. Based on assessment of the components.
Lactation: No end point data for material.	Not expected to cause harm to breast-fed children.
Specific Target Organ Toxicity (STOT)	
Single Exposure: No end point data for material.	Not expected to cause organ damage from a single exposure.
Repeated Exposure: No end point data for material.	Not expected to cause organ damage from prolonged or repeated exposure. Based on assessment of the components.

TOXICITY FOR SUBSTANCES

NAME	ACUTE TOXICITY
2,6-DI-TERT-BUTYL-P-CRESOL	Oral Lethality: LD50 0.89 g/kg (Rat)

OTHER INFORMATION

For the product itself:

Repeated and/or prolonged exposure may cause irritation to the skin, eyes, or respiratory tract. Small amounts of liquid aspirated into the lungs during ingestion or from vomiting may cause chemical pneumonitis or pulmonary edema.

Contains:

Base oil severely refined: Not carcinogenic in animal studies. Representative material passes IP-346, Modified Ames test, and/or other screening tests. Dermal and inhalation studies showed minimal effects; lung non-specific infiltration of immune cells, oil deposition and minimal granuloma formation. Not sensitizing in test animals.

The following ingredients are cited on the lists below: None.

--REGULATORY LISTS SEARCHED--

Product Name: MOBIL AERO HFA
Revision Date: 01 Oct 2015
Page 9 of 12

1 = NTP CARC
2 = NTP SUS

3 = IARC 1
4 = IARC 2A

5 = IARC 2B
6 = OSHA CARC

SECTION 12 ECOLOGICAL INFORMATION

The information given is based on data available for the material, the components of the material, and similar materials.

ECOTOXICITY

Material -- Not expected to be harmful to aquatic organisms.

MOBILITY

More volatile component -- Highly volatile, will partition rapidly to air. Not expected to partition to sediment and wastewater solids.

Less volatile component -- Low solubility and floats and is expected to migrate from water to the land. Expected to partition to sediment and wastewater solids.

PERSISTENCE AND DEGRADABILITY

Biodegradation:

Components -- Expected to be inherently biodegradable

BIOACCUMULATION POTENTIAL

Majority of components -- Has the potential to bioaccumulate, however metabolism or physical properties may reduce the bioconcentration or limit bioavailability.

SECTION 13 DISPOSAL CONSIDERATIONS

Disposal recommendations based on material as supplied. Disposal must be in accordance with current applicable laws and regulations, and material characteristics at time of disposal.

DISPOSAL RECOMMENDATIONS

Product is suitable for burning in an enclosed controlled burner for fuel value or disposal by supervised incineration at very high temperatures to prevent formation of undesirable combustion products. Protect the environment. Dispose of used oil at designated sites. Minimize skin contact. Do not mix used oils with solvents, brake fluids or coolants.

REGULATORY DISPOSAL INFORMATION

RCRA Information: The unused product, in our opinion, is not specifically listed by the EPA as a hazardous waste (40 CFR, Part 261D), nor is it formulated to contain materials which are listed as hazardous wastes. It does not exhibit the hazardous characteristics of ignitability, corrosivity or reactivity and is not formulated with contaminants as determined by the Toxicity Characteristic Leaching Procedure (TCLP). However, used product may be regulated.

Empty Container Warning Empty Container Warning (where applicable): Empty containers may contain residue and can be dangerous. Do not attempt to refill or clean containers without proper instructions. Empty drums should be

Product Name: MOBIL AERO HFA
Revision Date: 01 Oct 2015
Page 10 of 12

completely drained and safely stored until appropriately reconditioned or disposed. Empty containers should be taken for recycling, recovery, or disposal through suitably qualified or licensed contractor and in accordance with governmental regulations. DO NOT PRESSURISE, CUT, WELD, BRAZE, SOLDER, DRILL, GRIND, OR EXPOSE SUCH CONTAINERS TO HEAT, FLAME, SPARKS, STATIC ELECTRICITY, OR OTHER SOURCES OF IGNITION. THEY MAY EXPLODE AND CAUSE INJURY OR DEATH.

SECTION 14	TRANSPORT INFORMATION
-------------------	------------------------------

LAND (DOT)

Proper Shipping Name: COMBUSTIBLE LIQUID, N.O.S. (Distillates (Petroleum), Hydrotreated Light)
Hazard Class & Division: COMBUSTIBLE LIQUID
ID Number: NA1993
Packing Group: III
ERG Number: 128
Label(s): NONE
Transport Document Name: NA1993, COMBUSTIBLE LIQUID, N.O.S. (Distillates (Petroleum), Hydrotreated Light), COMBUSTIBLE LIQUID, PG III

Footnote: This material is not regulated under 49 CFR in a container of 119 gallon capacity or less when transported solely by land, as long as the material is not a hazardous waste, a marine pollutant, or specifically listed as a hazardous substance.

LAND (TDG): Not Regulated for Land Transport

SEA (IMDG): Not Regulated for Sea Transport according to IMDG-Code

Marine Pollutant: No

AIR (IATA): Not Regulated for Air Transport

SECTION 15	REGULATORY INFORMATION
-------------------	-------------------------------

OSHA HAZARD COMMUNICATION STANDARD: This material is considered hazardous in accordance with OSHA HazCom 2012, 29 CFR 1910.1200.

Listed or exempt from listing/notification on the following chemical inventories: AICS, DSL, ENCS, IECSC, KECI, PICCS, TCSI, TSCA

EPCRA SECTION 302: This material contains no extremely hazardous substances.

SARA (311/312) REPORTABLE HAZARD CATEGORIES: Fire. Immediate Health. Delayed Health.

SARA (313) TOXIC RELEASE INVENTORY: This material contains no chemicals subject to the supplier notification requirements of the SARA 313 Toxic Release Program.

Product Name: MOBIL AERO HFA
 Revision Date: 01 Oct 2015
 Page 11 of 12

The following ingredients are cited on the lists below:

Chemical Name	CAS Number	List Citations
DISTILLATES (PETROLEUM), HYDROTREATED LIGHT	64742-47-8	1, 17, 18
HYDROTREATED LIGHT NAPHTHENIC DISTILLATE (PETROLEUM)	64742-53-6	1, 4, 13, 17, 18
HYDROTREATED MIDDLE DISTILLATE (PETROLEUM)	64742-46-7	1, 4, 17, 18

--REGULATORY LISTS SEARCHED--

1 = ACGIH ALL	6 = TSCA 5a2	11 = CA P65 REPRO	16 = MN RTK
2 = ACGIH A1	7 = TSCA 5e	12 = CA RTK	17 = NJ RTK
3 = ACGIH A2	8 = TSCA 6	13 = IL RTK	18 = PA RTK
4 = OSHA Z	9 = TSCA 12b	14 = LA RTK	19 = RI RTK
5 = TSCA 4	10 = CA P65 CARC	15 = MI 293	

Code key: CARC=Carcinogen; REPRO=Reproductive

SECTION 16	OTHER INFORMATION
-------------------	--------------------------

N/D = Not determined, N/A = Not applicable

KEY TO THE H-CODES CONTAINED IN SECTION 3 OF THIS DOCUMENT (for information only):

H227: Combustible liquid; Flammable Liquid, Cat 4
 H304: May be fatal if swallowed and enters airways; Aspiration, Cat 1
 H400: Very toxic to aquatic life; Acute Env Tox, Cat 1
 H410: Very toxic to aquatic life with long lasting effects; Chronic Env Tox, Cat 1

THIS SAFETY DATA SHEET CONTAINS THE FOLLOWING REVISIONS:

Revision Changes:

Section 01: Company Mailing Address information was modified.
 Section 05: Hazardous Combustion Products information was modified.
 Section 15: List Citations Table information was modified.
 Section 15: National Chemical Inventory Listing information was modified.
 Section 14: Marine Pollutant information was modified.
 Composition: Component Table information was modified.
 Section 08: Exposure Limits Table information was modified.
 Section 16: Revision Information - Implementation of GHS requirements phrase. information was deleted.

The information and recommendations contained herein are, to the best of ExxonMobil's knowledge and belief, accurate and reliable as of the date issued. You can contact ExxonMobil to insure that this document is the most current available from ExxonMobil. The information and recommendations are offered for the user's consideration and examination. It is the user's responsibility to satisfy itself that the product is suitable for the intended use. If buyer repackages this product, it is the user's responsibility to insure proper health, safety and other necessary information is included with and/or on the container. Appropriate warnings and safe-handling procedures should be provided to handlers and users. Alteration of this document is strictly prohibited. Except to the extent required by law,



Product Name: MOBIL AERO HFA
Revision Date: 01 Oct 2015
Page 12 of 12

re-publication or retransmission of this document, in whole or in part, is not permitted. The term, "ExxonMobil" is used for convenience, and may include any one or more of ExxonMobil Chemical Company, Exxon Mobil Corporation, or any affiliates in which they directly or indirectly hold any interest.

Internal Use Only

MHC: 2A, 0, 0, 0, 1, 1

PPEC: C

DGN: 2005454XUS (552975)

Copyright 2002 Exxon Mobil Corporation, All rights reserved



APPENDIX VII

5721

Safety Data Sheet

MIL-PRF-83282 Hydraulic Fluid

Section 1. Identification

Product name Brayco Micronic 882
SDS # 451700
Historic SDS #: 27009
Code 451700-US03

Relevant identified uses of the substance or mixture and uses advised against

Product use Hydraulic fluid
 For specific application advice see appropriate Technical Data Sheet or consult our company representative.

Supplier Castrol Industrial North America, Inc.
 150 W. Warrenville Road
 Naperville, IL 60563
 Product Information: +1-877-641-1600

BP Lubricants USA Inc.
 1500 Valley Road
 Wayne, NJ 07470
 Telephone: (973) 633-2200

EMERGENCY SPILL INFORMATION: 1 (800) 424-9300 CHEMTREC (USA)

Section 2. Hazards identification

OSHA/HCS status This material is considered hazardous by the OSHA Hazard Communication Standard (29 CFR 1910.1200).

Classification of the substance or mixture ASPIRATION HAZARD - Category 1

GHS label elements

Hazard pictograms



Signal word Danger

Hazard statements May be fatal if swallowed and enters airways.

Precautionary statements

Prevention Not applicable.

Response IF SWALLOWED: Immediately call a POISON CENTER or physician. Do NOT induce vomiting.

Storage Store locked up.

Disposal Dispose of contents and container in accordance with all local, regional, national and international regulations.

Hazards not otherwise classified

Defatting to the skin.
 Note: High Pressure Applications
 Injections through the skin resulting from contact with the product at high pressure constitute a major medical emergency.
 See 'Notes to physician' under First-Aid Measures, Section 4 of this Safety Data Sheet.

Product name Brayco Micronic 882

Product code 451700-US03

Page: 1/9

Version 2 **Date of issue** 03/27/2017.

Format US

Language ENGLISH

(US)

(ENGLISH)

Section 3. Composition/information on ingredients

Substance/mixture Mixture

Synthetic lubricant and additives.

Ingredient name	CAS number	%
1-Decene, homopolymer, hydrogenated	68037-01-4	≥50 - ≤75

Any concentration shown as a range is to protect confidentiality or is due to batch variation.

There are no additional ingredients present which, within the current knowledge of the supplier and in the concentrations applicable, are classified as hazardous to health and hence require reporting in this section.

Occupational exposure limits, if available, are listed in Section 8.

Section 4. First aid measures

Description of necessary first aid measures

Eye contact	In case of contact, immediately flush eyes with plenty of water for at least 15 minutes. Eyelids should be held away from the eyeball to ensure thorough rinsing. Check for and remove any contact lenses. Get medical attention.
Skin contact	Wash skin thoroughly with soap and water or use recognized skin cleanser. Remove contaminated clothing and shoes. Wash clothing before reuse. Clean shoes thoroughly before reuse. Get medical attention if symptoms occur.
Inhalation	If inhaled, remove to fresh air. Get medical attention if symptoms occur.
Ingestion	Do not induce vomiting. Never give anything by mouth to an unconscious person. If unconscious, place in recovery position and get medical attention immediately. Aspiration hazard if swallowed. Can enter lungs and cause damage. Get medical attention immediately.
Protection of first-aiders	No action shall be taken involving any personal risk or without suitable training. It may be dangerous to the person providing aid to give mouth-to-mouth resuscitation.

Most important symptoms/effects, acute and delayed

See Section 11 for more detailed information on health effects and symptoms.

Indication of immediate medical attention and special treatment needed, if necessary

Notes to physician	1 Treatment should in general be symptomatic and directed to relieving any effects. Product can be aspirated on swallowing or following regurgitation of stomach contents, and can cause severe and potentially fatal chemical pneumonitis, which will require urgent treatment. Because of the risk of aspiration, induction of vomiting and gastric lavage should be avoided. Gastric lavage should be undertaken only after endotracheal intubation. Monitor for cardiac dysrhythmias.
---------------------------	-------------------------------------------------------------------------------------------------------------------------------------------------------------------------------------------------------------------------------------------------------------------------------------------------------------------------------------------------------------------------------------------------------------------------------------------------------------------------------------------

Note: High Pressure Applications
Injections through the skin resulting from contact with the product at high pressure constitute a major medical emergency. Injuries may not appear serious at first but within a few hours tissue becomes swollen, discolored and extremely painful with extensive subcutaneous necrosis.
Surgical exploration should be undertaken without delay. Thorough and extensive debridement of the wound and underlying tissue is necessary to minimize tissue loss and prevent or limit permanent damage. Note that high pressure may force the product considerable distances along tissue planes.

Specific treatments	No specific treatment.
----------------------------	------------------------

Section 5. Fire-fighting measures

Extinguishing media

Suitable extinguishing media	In case of fire, use foam, dry chemical or carbon dioxide extinguisher or spray.
Unsuitable extinguishing media	Do not use water jet.

Product name Brayco Micronic 882

Product code 451700-US03

Page: 2/9

Version 2 **Date of issue** 03/27/2017.

Format US

Language ENGLISH

(US)

(ENGLISH)

Section 5. Fire-fighting measures

Specific hazards arising from the chemical	In a fire or if heated, a pressure increase will occur and the container may burst.
Hazardous combustion products	Combustion products may include the following: carbon dioxide carbon monoxide
Special protective actions for fire-fighters	Promptly isolate the scene by removing all persons from the vicinity of the incident if there is a fire. No action shall be taken involving any personal risk or without suitable training.
Special protective equipment for fire-fighters	Fire-fighters should wear positive pressure self-contained breathing apparatus (SCBA) and full turnout gear.

Section 6. Accidental release measures

Personal precautions, protective equipment and emergency procedures

For non-emergency personnel	No action shall be taken involving any personal risk or without suitable training. Evacuate surrounding areas. Keep unnecessary and unprotected personnel from entering. Do not touch or walk through spilled material. Avoid breathing vapor or mist. Provide adequate ventilation. Put on appropriate personal protective equipment. Floors may be slippery; use care to avoid falling. Contact emergency personnel.
For emergency responders	Entry into a confined space or poorly ventilated area contaminated with vapor, mist or fume is extremely hazardous without the correct respiratory protective equipment and a safe system of work. Wear self-contained breathing apparatus. Wear a suitable chemical protective suit. Chemical resistant boots. See also the information in "For non-emergency personnel".
Environmental precautions	Avoid dispersal of spilled material and runoff and contact with soil, waterways, drains and sewers. Inform the relevant authorities if the product has caused environmental pollution (sewers, waterways, soil or air).

Methods and materials for containment and cleaning up

Small spill	Stop leak if without risk. Move containers from spill area. Absorb with an inert material and place in an appropriate waste disposal container. Dispose of via a licensed waste disposal contractor.
Large spill	Stop leak if without risk. Move containers from spill area. Approach release from upwind. Prevent entry into sewers, water courses, basements or confined areas. Contain and collect spillage with non-combustible, absorbent material e.g. sand, earth, vermiculite or diatomaceous earth and place in container for disposal according to local regulations. Contaminated absorbent material may pose the same hazard as the spilled product. Dispose of via a licensed waste disposal contractor.

Section 7. Handling and storage

Precautions for safe handling

Protective measures	Put on appropriate personal protective equipment (see Section 8). Avoid breathing vapor or mist. Avoid contact with eyes, skin and clothing. Empty containers retain product residue and can be hazardous. Keep in the original container or an approved alternative made from a compatible material, kept tightly closed when not in use. Do not reuse container. Do not swallow. Aspiration hazard if swallowed. Can enter lungs and cause damage. Never siphon by mouth.
Advice on general occupational hygiene	Eating, drinking and smoking should be prohibited in areas where this material is handled, stored and processed. Wash thoroughly after handling. Remove contaminated clothing and protective equipment before entering eating areas. See also Section 8 for additional information on hygiene measures.

Product name	Brayco Micronic 882	Product code	451700-US03	Page:	3/9		
Version	2	Date of issue	03/27/2017.	Format	US	Language	ENGLISH
					(US)		(ENGLISH)

Section 7. Handling and storage

Conditions for safe storage, including any incompatibilities

Store in accordance with local regulations. Store in original container protected from direct sunlight in a dry, cool and well-ventilated area, away from incompatible materials (see Section 10) and food and drink. Store locked up. Keep container tightly closed and sealed until ready for use. Store and use only in equipment/containers designed for use with this product. Containers that have been opened must be carefully resealed and kept upright to prevent leakage. Do not store in unlabeled containers. Use appropriate containment to avoid environmental contamination.

Section 8. Exposure controls/personal protection

Control parameters

Occupational exposure limits

Decene, homopolymer, hydrogenated

None.

Appropriate engineering controls

All activities involving chemicals should be assessed for their risks to health, to ensure exposures are adequately controlled. Personal protective equipment should only be considered after other forms of control measures (e.g. engineering controls) have been suitably evaluated. Personal protective equipment should conform to appropriate standards, be suitable for use, be kept in good condition and properly maintained. Your supplier of personal protective equipment should be consulted for advice on selection and appropriate standards. For further information contact your national organisation for standards.

Provide exhaust ventilation or other engineering controls to keep the relevant airborne concentrations below their respective occupational exposure limits.

The final choice of protective equipment will depend upon a risk assessment. It is important to ensure that all items of personal protective equipment are compatible.

Environmental exposure controls

Emissions from ventilation or work process equipment should be checked to ensure they comply with the requirements of environmental protection legislation. In some cases, fume scrubbers, filters or engineering modifications to the process equipment will be necessary to reduce emissions to acceptable levels.

Individual protection measures

Hygiene measures

Wash hands, forearms and face thoroughly after handling chemical products, before eating, smoking and using the lavatory and at the end of the working period. Appropriate techniques should be used to remove potentially contaminated clothing. Wash contaminated clothing before reusing. Ensure that eyewash stations and safety showers are close to the workstation location.

Eye/face protection

Safety glasses with side shields.

Skin protection

Hand protection

Wear protective gloves if prolonged or repeated contact is likely. Wear chemical resistant gloves. Recommended: Nitrile gloves. The correct choice of protective gloves depends upon the chemicals being handled, the conditions of work and use, and the condition of the gloves (even the best chemically resistant glove will break down after repeated chemical exposures). Most gloves provide only a short time of protection before they must be discarded and replaced. Because specific work environments and material handling practices vary, safety procedures should be developed for each intended application. Gloves should therefore be chosen in consultation with the supplier/manufacturer and with a full assessment of the working conditions.

Body protection

Use of protective clothing is good industrial practice. Cotton or polyester/cotton overalls will only provide protection against light superficial contamination that will not soak through to the skin. Overalls should be laundered on a regular basis. When the risk of skin exposure is high (e.g. when cleaning up spillages or if there is a risk of splashing) then chemical resistant aprons and/or impervious chemical suits and boots will be required. Personal protective equipment for the body should be selected based on the task being performed and the risks involved and should be approved by a specialist before handling this product.

Other skin protection

Appropriate footwear and any additional skin protection measures should be selected based on the task being performed and the risks involved and should be approved by a specialist before handling this product.

Product name Brayco Micronic 882

Product code 451700-US03

Page: 4/9

Version 2 **Date of issue** 03/27/2017.

Format US

Language ENGLISH

(US)

(ENGLISH)

Section 8. Exposure controls/personal protection

Respiratory protection

In case of insufficient ventilation, wear suitable respiratory equipment.
The correct choice of respiratory protection depends upon the chemicals being handled, the conditions of work and use, and the condition of the respiratory equipment. Safety procedures should be developed for each intended application. Respiratory protection equipment should therefore be chosen in consultation with the supplier/manufacturer and with a full assessment of the working conditions.

Section 9. Physical and chemical properties

Appearance

Physical state	Liquid.
Color	Red. [Dark]
Odor	Mild.
Odor threshold	Not available.
pH	Not available.
Melting point	Not available.
Boiling point	Not available.
Flash point	Open cup: 205°C (401°F) [Cleveland.]
Pour point	55 °C
Evaporation rate	Not available.
Flammability (solid, gas)	Not applicable. Based on - Physical state
Lower and upper explosive (flammable) limits	Not available.
Vapor pressure	Not available.
Vapor density	Not available.
Density	<1000 kg/m ³ (<1 g/cm ³) at 15°C
Solubility	insoluble in water.
Partition coefficient: n-octanol/water	Not available.
Auto-ignition temperature	Not available.
Decomposition temperature	Not available.
Viscosity	Kinematic: 14 mm ² /s (14 cSt) at 40°C

Section 10. Stability and reactivity

Reactivity	No specific test data available for this product. Refer to Conditions to avoid and Incompatible materials for additional information.
Chemical stability	The product is stable.
Possibility of hazardous reactions	Under normal conditions of storage and use, hazardous reactions will not occur. Under normal conditions of storage and use, hazardous polymerization will not occur.
Conditions to avoid	No specific data.
Incompatible materials	Reactive or incompatible with the following materials: oxidizing materials.
Hazardous decomposition products	Under normal conditions of storage and use, hazardous decomposition products should not be produced.

Product name Brayco Micronic 882

Product code 451700-US03

Page: 5/9

Version 2 Date of issue 03/27/2017.

Format US

Language ENGLISH

(US)

(ENGLISH)

Section 11. Toxicological information

Information on toxicological effects

Aspiration hazard

Name	Result
 Decene, homopolymer, hydrogenated	ASPIRATION HAZARD - Category 1

Information on the likely routes of exposure Routes of entry anticipated: Dermal, Inhalation.

Potential acute health effects

Eye contact	No known significant effects or critical hazards.
Skin contact	No known significant effects or critical hazards.
Inhalation	Vapor inhalation under ambient conditions is not normally a problem due to low vapor pressure.
Ingestion	Aspiration hazard if swallowed -- harmful or fatal if liquid is aspirated into lungs.

Symptoms related to the physical, chemical and toxicological characteristics

Eye contact	No specific data.
Skin contact	Adverse symptoms may include the following: irritation dryness cracking
Inhalation	No specific data.
Ingestion	Adverse symptoms may include the following: nausea or vomiting

Delayed and immediate effects and also chronic effects from short and long term exposure

Short term exposure

Potential immediate effects	Not available.
Potential delayed effects	Not available.

Long term exposure

Potential immediate effects	Not available.
Potential delayed effects	Not available.

Potential chronic health effects

General	No known significant effects or critical hazards.
Carcinogenicity	No known significant effects or critical hazards.
Mutagenicity	No known significant effects or critical hazards.
Teratogenicity	No known significant effects or critical hazards.
Developmental effects	No known significant effects or critical hazards.
Fertility effects	No known significant effects or critical hazards.

Numerical measures of toxicity

Acute toxicity estimates

Not available.

Product name	Brayco Micronic 882	Product code	451700-US03	Page:	6/9
Version	2	Date of issue	03/27/2017.	Format	US (US)
				Language	ENGLISH (ENGLISH)

Section 12. Ecological information

Toxicity

No testing has been performed by the manufacturer.

Persistence and degradability

Not expected to be rapidly degradable.

Bioaccumulative potential

Not available.

Mobility in soil

Soil/water partition
coefficient (K_{oc})

Not available.

Mobility

Non-volatile.Liquid.insoluble in water.

Other adverse effects

No known significant effects or critical hazards.

Section 13. Disposal considerations

Disposal methods

The generation of waste should be avoided or minimized wherever possible. Significant quantities of waste product residues should not be disposed of via the foul sewer but processed in a suitable effluent treatment plant. Dispose of surplus and non-recyclable products via a licensed waste disposal contractor. Disposal of this product, solutions and any by-products should at all times comply with the requirements of environmental protection and waste disposal legislation and any regional local authority requirements. Waste packaging should be recycled. Incineration or landfill should only be considered when recycling is not feasible. This material and its container must be disposed of in a safe way. Care should be taken when handling emptied containers that have not been cleaned or rinsed out. Empty containers or liners may retain some product residues. Avoid dispersal of spilled material and runoff and contact with soil, waterways, drains and sewers.

Section 14. Transport information

	DOT Classification	TDG Classification	IMDG	IATA
UN number	Not regulated.	Not regulated.	Not regulated.	Not regulated.
UN proper shipping name	-	-	-	-
Transport hazard class(es)	-	-	-	-
Packing group	-	-	-	-
Environmental hazards	No.	No.	No.	No.
Additional information	-	-	-	-

Special precautions for user Not available.

Transport in bulk according to Annex II of MARPOL and the IBC Code Not available.

Product name Brayco Micronic 882

Product code 451700-US03

Page: 7/9

Version 2 Date of issue 03/27/2017.

Format US

Language ENGLISH

(US)

(ENGLISH)

Section 15. Regulatory information

U.S. Federal regulations

United States inventory (TSCA 8b) All components are listed or exempted.

TSCA 12(b) one-time export: 2,2',6,6'-tetra-tert-butyl-4,4'-methylenediphenol

SARA 302/304

Composition/Information on ingredients

No products were found.

SARA 311/312

Classification Not applicable.

SARA 313

Form R - Reporting requirements This product does not contain any hazardous ingredients at or above regulated thresholds.

Supplier notification This product does not contain any hazardous ingredients at or above regulated thresholds.

State regulations

Massachusetts None of the components are listed.

New Jersey None of the components are listed.

Pennsylvania None of the components are listed.

California Prop. 65 No products were found.

Other regulations

Australia inventory (AICS) All components are listed or exempted.

Canada inventory All components are listed or exempted.

China inventory (IECSC) All components are listed or exempted.

Japan inventory (ENCS) All components are listed or exempted.

Korea inventory (KECI) All components are listed or exempted.

Philippines inventory (PICCS) All components are listed or exempted.

Taiwan Chemical Substances Inventory (TCSI) Not determined.

REACH Status The company, as identified in Section 1, sells this product in the EU in compliance with the current requirements of REACH.

Section 16. Other information

National Fire Protection Association (U.S.A.)



History

Date of issue/Date of revision 03/27/2017.

Date of previous issue 11/22/2016.

Prepared by Product Stewardship

Key to abbreviations

ACGIH = American Conference of Industrial Hygienists
ATE = Acute Toxicity Estimate
BCF = Bioconcentration Factor
CAS Number = Chemical Abstracts Service Registry Number
GHS = Globally Harmonized System of Classification and Labelling of Chemicals
IATA = International Air Transport Association
IBC = Intermediate Bulk Container

Product name	Brayco Micronic 882	Product code	451700-US03	Page:	8/9	
Version	2	Date of issue	03/27/2017.	Format	US	
					Language	ENGLISH
					(US)	(ENGLISH)

Section 16. Other information

IMDG = International Maritime Dangerous Goods
LogPow = logarithm of the octanol/water partition coefficient
MARPOL = International Convention for the Prevention of Pollution From Ships, 1973 as modified by the Protocol of 1978. ("Marpol" = marine pollution)
OEL = Occupational Exposure Limit
SDS = Safety Data Sheet
STEL = Short term exposure limit
TWA = Time weighted average
UN = United Nations
UN Number = United Nations Number, a four digit number assigned by the United Nations Committee of Experts on the Transport of Dangerous Goods.
Varies = may contain one or more of the following 101316-69-2, 101316-70-5, 101316-71-6, 101316-72-7, 64741-88-4, 64741-89-5, 64741-95-3, 64741-96-4, 64741-97-5, 64742-01-4, 64742-44-5, 64742-45-6, 64742-52-5, 64742-53-6, 64742-54-7, 64742-55-8, 64742-56-9, 64742-57-0, 64742-58-1, 64742-62-7, 64742-63-8, 64742-64-9, 64742-65-0, 64742-70-7, 72623-85-9, 72623-86-0, 72623-87-1, 74869-22-0, 90669-74-2

✔ Indicates information that has changed from previously issued version.

[Notice to reader](#)

All reasonably practicable steps have been taken to ensure this data sheet and the health, safety and environmental information contained in it is accurate as of the date specified below. No warranty or representation, express or implied is made as to the accuracy or completeness of the data and information in this data sheet.

The data and advice given apply when the product is sold for the stated application or applications. You should not use the product other than for the stated application or applications without seeking advice from BP Group.

It is the user's obligation to evaluate and use this product safely and to comply with all applicable laws and regulations. The BP Group shall not be responsible for any damage or injury resulting from use, other than the stated product use of the material, from any failure to adhere to recommendations, or from any hazards inherent in the nature of the material. Purchasers of the product for supply to a third party for use at work, have a duty to take all necessary steps to ensure that any person handling or using the product is provided with the information in this sheet. Employers have a duty to tell employees and others who may be affected of any hazards described in this sheet and of any precautions that should be taken. You can contact the BP Group to ensure that this document is the most current available. Alteration of this document is strictly prohibited.

Product name	Brayco Micronic 882	Product code	451700-US03	Page: 9/9
Version 2	Date of issue 03/27/2017.	Format US (US)	Language ENGLISH (ENGLISH)	



APPENDIX VIII

5731

**Safety Data Sheet
Skydrol Hydraulic Fluid**

Skydrol® LD4 Fire Resistant Hydraulic Fluid

Version Revision Date: SDS Number: Date of last issue: 06/02/2015
2.2 08/09/2016 150000093409 Date of first issue: 10/24/2013
SDSUS / PRD / 0001

SECTION 1. IDENTIFICATION

Product name : Skydrol® LD4 Fire Resistant Hydraulic Fluid

Product code : P3410201

Manufacturer or supplier's details

Company name of supplier : Eastman Chemical Company

Address : 200 South Wilcox Drive
 Kingsport TN 37660-5280

Telephone : (423) 229-2000

Emergency telephone number : CHEMTREC: +1-800-424-9300, +1-703-527-3887 CCN7321
For emergency transportation information, in the United States:
call CHEMTREC at 800-424-9300 or call 423-229-2000.

Recommended use of the chemical and restrictions on use

Recommended use : Hydraulic fluids

Restrictions on use : None known.

SECTION 2. HAZARDS IDENTIFICATION**GHS Classification**

Skin irritation : Category 2

Carcinogenicity : Category 2

GHS label elements

Hazard pictograms :



Signal word : Warning

Hazard statements : H315 Causes skin irritation.
 H351 Suspected of causing cancer.

Precautionary statements : **Prevention:**
P201 Obtain special instructions before use.
P202 Do not handle until all safety precautions have been read
and understood.
P264 Wash skin thoroughly after handling.
P280 Wear protective gloves/ protective clothing/ eye protection/
face protection.

Skydrol® LD4 Fire Resistant Hydraulic Fluid

Version 2.2 Revision Date: 08/09/2016 SDS Number: 150000093409 Date of last issue: 06/02/2015
 Date of first issue: 10/24/2013
 SDSUS / PRD / 0001

Response:

P302 + P352 IF ON SKIN: Wash with plenty of soap and water.
 P308 + P313 IF exposed or concerned: Get medical advice/ attention.

P332 + P313 If skin irritation occurs: Get medical advice/ attention.

P362 Take off contaminated clothing and wash before reuse.

Storage:

P405 Store locked up.

Disposal:

P501 Dispose of contents/ container to an approved waste disposal plant.

Other hazards

None known.

SECTION 3. COMPOSITION/INFORMATION ON INGREDIENTS**Components**

Chemical name	CAS-No.	Concentration (% w/w)
Tributyl phosphate	126-73-8	55 - 65
Dibutylphenylphosphate	2528-36-1	20 - 30
Butyl diphenyl phosphate	2752-95-6	5 - 10
7-Oxabicyclo[4.1.0]heptane-3-carboxylic acid, 2-ethylhexyl ester	62256-00-2	< 10
butylated hydroxytoluene	128-37-0	1

SECTION 4. FIRST AID MEASURES

- If inhaled : Move to fresh air.
 If breathing is difficult, give oxygen.
 Consult a physician if necessary.
- In case of skin contact : Wash off immediately with plenty of water for at least 15 minutes.
 Get medical attention if symptoms occur.
 Wash contaminated clothing before reuse.
- In case of eye contact : In case of contact, immediately flush eyes with plenty of water for at least 15 minutes.
 Get medical attention if symptoms occur.
- If swallowed : Call a physician or poison control centre immediately.
 Do not induce vomiting without medical advice.
 Rinse mouth.
 Never give anything by mouth to an unconscious person.
- Most important symptoms and effects, both acute and delayed : Causes skin irritation.
 Suspected of causing cancer.

Skydrol® LD4 Fire Resistant Hydraulic Fluid

Version Revision Date: SDS Number: Date of last issue: 06/02/2015
 2.2 08/09/2016 15000093409 Date of first issue: 10/24/2013
 SDSUS / PRD / 0001

Wash thoroughly after handling.
 Wash contaminated clothing before reuse.
 Drain or remove substance from equipment prior to break-in or maintenance.
 Handle in accordance with good industrial hygiene and safety practice.

Conditions for safe storage : Store locked up.
 Keep container tightly closed in a dry and well-ventilated place.
 Keep in a cool place away from oxidizing agents.

SECTION 8. EXPOSURE CONTROLS/PERSONAL PROTECTION**Components with workplace control parameters**

Components	CAS-No.	Value type (Form of exposure)	Control parameters / Permissible concentration	Basis
Tributyl phosphate	126-73-8	TWA (Inhalable fraction and vapor)	5 mg/m ³	ACGIH
		TWA	0.2 ppm 2.5 mg/m ³	NIOSH REL
		TWA	5 mg/m ³	OSHA Z-1
		TWA	0.2 ppm 2.5 mg/m ³	OSHA P0
Dibutylphenylphosphate	2528-36-1	TWA	0.3 ppm	ACGIH
butylated hydroxytoluene	128-37-0	TWA (Inhalable fraction and vapor)	2 mg/m ³	ACGIH
		TWA	10 mg/m ³	NIOSH REL
		TWA	10 mg/m ³	OSHA P0

Hazardous components without workplace control parameters

Components	CAS-No.
7-Oxabicyclo[4.1.0]heptane-3-carboxylic acid, 2-ethylhexyl ester	62256-00-2

Engineering measures : Good general ventilation (typically 10 air changes per hour) should be used. Ventilation rates should be matched to conditions. If applicable, use process enclosures, local exhaust ventilation, or other engineering controls to maintain airborne levels below recommended exposure limits. If exposure limits have not been established, maintain airborne levels to an acceptable level.

Personal protective equipment

Respiratory protection : Use a properly fitted, particulate filter respirator complying with an approved standard if a risk assessment indicates this is necessary.

Skydrol® LD4 Fire Resistant Hydraulic Fluid

Version	Revision Date:	SDS Number:	Date of last issue: 06/02/2015
2.2	08/09/2016	150000093409	Date of first issue: 10/24/2013

SDSUS / PRD / 0001

Respirator selection, use, and maintenance must be in accordance with regulatory requirements, if applicable. If engineering controls do not maintain airborne concentrations below recommended exposure limits (where applicable) or to an acceptable level (in countries where exposure limits have not been established), an approved respirator must be worn.

Hand protection

Remarks : Wear suitable gloves. Please observe the instructions regarding permeability and breakthrough time which are provided by the supplier of the gloves. Also take into consideration the specific local conditions under which the product is used, such as the danger of cuts, abrasion, and the contact time. After contamination with product change the gloves immediately and dispose of them according to relevant national and local regulations.

Eye protection : Wear safety glasses with side shields (or goggles).

Skin and body protection : Wear suitable protective clothing.

Protective measures : Ensure that eye flushing systems and safety showers are located close to the working place.

SECTION 9. PHYSICAL AND CHEMICAL PROPERTIES

Appearance	: oily
Colour	: purple
Odour	: odourless
pH	: No data available
Melting point/range	: < -62 °C
Flash point	: 160 °C Method: Cleveland open cup
Vapour pressure	: 0.27 hPa (25 °C)
Relative density	: 1.004 - 1.014 (25 °C)
Viscosity	
Viscosity, kinematic	: < 2000 mm ² /s (-54 °C)
	11.15 mm ² /s (38 °C)
	3.83 mm ² /s (99 °C)

Skydrol® LD4 Fire Resistant Hydraulic Fluid

Version Revision Date: SDS Number: Date of last issue: 06/02/2015
2.2 08/09/2016 150000093409 Date of first issue: 10/24/2013
SDSUS / PRD / 0001

SECTION 10. STABILITY AND REACTIVITY

Reactivity	: None reasonably foreseeable.
Chemical stability	: Stable under normal conditions.
Possibility of hazardous reactions	: None known.
Conditions to avoid	: None known.
Incompatible materials	: Strong oxidizing agents
Hazardous decomposition products	: Emits acrid smoke and fumes when heated to decomposition.

SECTION 11. TOXICOLOGICAL INFORMATION**Acute toxicity**

Not classified based on available information.

Product:

Acute oral toxicity	: LD50 (Rat, Male and Female): 2,100 mg/kg
Acute inhalation toxicity	: LC50 (Rat, male): > 5.8 mg/l Exposure time: 4 h Test atmosphere: dust/mist Assessment: The substance or mixture has no acute inhalation toxicity Remarks: (highest concentration tested)
Acute dermal toxicity	: LD50 Dermal (Rabbit, Male and Female): > 3,160 mg/kg Assessment: The substance or mixture has no acute dermal toxicity

Components:**Tributyl phosphate:**

Acute oral toxicity	: LD50 Oral (Rat, Male and Female): 1,553 mg/kg Method: Acute Oral Toxicity Assessment: Harmful if swallowed.
Acute inhalation toxicity	: LC50 (Rat, Male and Female): > 4.242 mg/l Exposure time: 4 h Test atmosphere: dust/mist Assessment: The substance or mixture has no acute inhalation toxicity
Acute dermal toxicity	: LD50 Dermal (Rabbit, Male and Female): > 3,100 mg/kg Assessment: The substance or mixture has no acute dermal toxicity

Dibutylphenylphosphate:

Skydrol® LD4 Fire Resistant Hydraulic Fluid

Version 2.2 Revision Date: 08/09/2016 SDS Number: 150000093409 Date of last issue: 06/02/2015
Date of first issue: 10/24/2013
SDSUS / PRD / 0001

Acute oral toxicity : Acute toxicity estimate (Rat, Male and Female): 2,400 - 3,000 mg/kg
Assessment: Not classified

Acute inhalation toxicity : LCLo (Rat, Male and Female): > 5 mg/l
Exposure time: 4 h
Test atmosphere: dust/mist

LC50 (Rat, Male and Female): > 5 mg/l
Exposure time: 4 h
Test atmosphere: dust/mist
Assessment: Not classified

Acute dermal toxicity : LD50 Dermal (Rabbit, Male and Female): > 5,000 mg/kg
Assessment: Not classified

7-Oxabicyclo[4.1.0]heptane-3-carboxylic acid, 2-ethylhexyl ester:

Acute oral toxicity : LD50 Oral (Rat, Male and Female): 4,470 mg/kg

Acute dermal toxicity : LD50 Dermal (Rabbit, Male and Female): > 7,940 mg/kg

butylated hydroxytoluene:

Acute oral toxicity : LD50 Oral (Rat): > 6,000 mg/kg

Acute dermal toxicity : LD50 Dermal (Guinea pig): > 20,000 mg/kg

Skin corrosion/irritation

Causes skin irritation.

Product:

Species: Rabbit
Exposure time: 24 h
Assessment: irritating
Result: moderate irritation

Components:**Tributyl phosphate:**

Species: Rabbit
Exposure time: 4 h
Assessment: Causes skin irritation.
Method: Acute Dermal Irritation / Corrosion
Result: irritating

Dibutylphenylphosphate:

Species: Rabbit
Assessment: Not classified

Species: Humans
Exposure time: 24 h
Assessment: Not classified

7-Oxabicyclo[4.1.0]heptane-3-carboxylic acid, 2-ethylhexyl ester:

Species: Rabbit

Skydrol® LD4 Fire Resistant Hydraulic Fluid

Version Revision Date: SDS Number: Date of last issue: 06/02/2015
2.2 08/09/2016 150000093409 Date of first issue: 10/24/2013
SDSUS / PRD / 0001

Exposure time: 24 h
Assessment: Not classified as hazardous.
Result: slight to moderate irritation

butylated hydroxytoluene:

Species: Rabbit
Exposure time: 24 h
Result: very slight

Serious eye damage/eye irritation

Not classified based on available information.

Product:

Species: Rabbit
Result: slight
Exposure time: 24 h
Assessment: Not classified

Components:**Tributyl phosphate:**

Species: Rabbit
Result: slight irritation
Exposure time: 24 h
Assessment: Not classified
Method: Acute Eye Irritation / Corrosion

Dibutylphenylphosphate:

Species: Rabbit
Result: slight
Assessment: Not classified

7-Oxabicyclo[4.1.0]heptane-3-carboxylic acid, 2-ethylhexyl ester:

Species: Rabbit
Result: slight irritation
Exposure time: 24 h
Assessment: Not classified

butylated hydroxytoluene:

Species: Rabbit
Result: none

Respiratory or skin sensitisation

Skin sensitisation: Not classified based on available information.
Respiratory sensitisation: Not classified based on available information.

Product:

Test Type: Human experience
Assessment: Not classified
Method: Human Repeat Insult Patch Test
Result: Does not cause skin sensitisation.

Components:

Skydrol® LD4 Fire Resistant Hydraulic Fluid

Version 2.2 Revision Date: 08/09/2016 SDS Number: 150000093409 Date of last issue: 06/02/2015
Date of first issue: 10/24/2013
SDSUS / PRD / 0001

Application Route: oral: gavage
Method: Mammalian Bone Marrow Chromosome Aberration Test
Result: negative

Dibutylphenylphosphate:

Genotoxicity in vitro

- : Test Type: Salmonella typhimurium assay (Ames test)
Metabolic activation: +/- activation
Method: Bacterial Reverse Mutation Assay
Result: negative
- : Test Type: Mutagenicity - Mammalian
Metabolic activation: +/- activation
Method: In vitro Mammalian Cell Gene Mutation Test
Result: negative
- : Test Type: Chromosome aberration test in vitro
Metabolic activation: +/- activation
Method: In vitro Mammalian Chromosome Aberration Test
Result: negative
- : Test Type: Mutagenicity - Mammalian
Metabolic activation: - activation
Method: Genetic Toxicology: DNA Damage and Repair, Un-scheduled DNA Synthesis in Mammalian Cells In Vitro
Result: negative

Genotoxicity in vivo

- : Species: Rat (Male and Female)
Application Route: intraperitoneal injection
Result: negative

7-Oxabicyclo[4.1.0]heptane-3-carboxylic acid, 2-ethylhexyl ester:

Genotoxicity in vitro

- : Test Type: Salmonella typhimurium assay (Ames test)
Metabolic activation: +/- activation
Method: Bacterial Reverse Mutation Assay
Result: negative
- : Test Type: Mutagenicity - Mammalian
Metabolic activation: +/- activation
Method: In vitro Mammalian Chromosome Aberration Test
Result: equivocal
- : Test Type: Mutagenicity - Mammalian
Metabolic activation: +/- activation
Method: In vitro Mammalian Cell Gene Mutation Test
Result: negative

Genotoxicity in vivo

- : Species: Rat (Male and Female)
Application Route: intraperitoneal injection
Method: Mammalian Bone Marrow Chromosome Aberration Test
Result: equivocal

Skydrol® LD4 Fire Resistant Hydraulic Fluid

Version Revision Date: SDS Number: Date of last issue: 06/02/2015
 2.2 08/09/2016 150000093409 Date of first issue: 10/24/2013
 SDSUS / PRD / 0001

Carcinogenicity

Suspected of causing cancer.

Components:**Tributyl phosphate:**

Species: Rat, (Male and Female)
 Application Route: Ingestion
 Method: EPA OTS 798.3300
 Remarks: Limited evidence of a carcinogenic effect.
 May cause cancer.

IARC

No component of this product present at levels greater than or equal to 0.1% is identified as probable, possible or confirmed human carcinogen by IARC.

OSHA

No component of this product present at levels greater than or equal to 0.1% is identified as a carcinogen or potential carcinogen by OSHA.

NTP

No component of this product present at levels greater than or equal to 0.1% is identified as a known or anticipated carcinogen by NTP.

Reproductive toxicity

Not classified based on available information.

Components:**Tributyl phosphate:**

Effects on fertility :
 : Test Type: Two Generation Reproductive Toxicity Study
 Species: Rat
 Sex: Male and Female
 Application Route: Ingestion
 NOAEL: 225 mg/kg,
 Method: EPA OTS 798.4900

Effects on foetal development : Species: Rat
 Application Route: Oral
 750 mg/kg
 Method: EPA OTS 798.4900

Dibutylphenylphosphate:

Effects on fertility :
 : Species: Rat
 Sex: Male and Female
 Application Route: Ingestion
 NOAEL: 5 mg/l,
 F1: Lowest observed adverse effect level 50 mg/kg,
 F2: Lowest observed adverse effect level 50 mg/kg,
 Method: EPA OTS 798.4900

Effects on foetal development : Species: Rat
 Application Route: oral (gavage)

Skydrol® LD4 Fire Resistant Hydraulic Fluid

Version 2.2 Revision Date: 08/09/2016 SDS Number: 150000093409 Date of last issue: 06/02/2015
Date of first issue: 10/24/2013
SDSUS / PRD / 0001

300 mg/kg
3 mg/kg

STOT - single exposure

Not classified based on available information.

Components:**Tributyl phosphate:**

Assessment: Based on available data, the classification criteria are not met.

Dibutylphenylphosphate:

Assessment: Not classified

STOT - repeated exposure

Not classified based on available information.

Components:**Tributyl phosphate:**

Assessment: Based on available data, the classification criteria are not met.

Dibutylphenylphosphate:

Exposure routes: inhalation (dust/mist/fume)

Target Organs: Respiratory system

Assessment: Not classified

Repeated dose toxicity**Product:**

Species: Rat, Male and Female

NOAEL: 40 mg/m³

Application Route: Inhalation

Exposure time: 28 days

Target Organs: Blood, Respiratory system

Remarks: Irritating to eyes and respiratory system.

Components:**Tributyl phosphate:**

Species: Mouse, Male and Female

NOEL: 75 mg/kg

Application Route: in feed

Exposure time: 90 days

Dibutylphenylphosphate:

Species: Rat, Male and Female

NOAEL: 5 mg/kg

LOAEL: 50 mg/kg

Application Route: oral (feed)

Exposure time: 90 days

Species: Rat, Male and Female

NOAEC: 5 mg/m³

Application Route: Inhalation

Skydrol® LD4 Fire Resistant Hydraulic Fluid

Version Revision Date: SDS Number: Date of last issue: 06/02/2015
2.2 08/09/2016 150000093409 Date of first issue: 10/24/2013
SDSUS / PRD / 0001

Exposure time: 90 days

Species: Rabbit, Male and Female
No observed adverse effect level: 100 mg/kg bw/day
Application Route: Dermal Study
Exposure time: 21 d

Aspiration toxicity

Not classified based on available information.

Product:

Not applicable

Components:

7-Oxabicyclo[4.1.0]heptane-3-carboxylic acid, 2-ethylhexyl ester:

Not applicable

Experience with human exposure**Product:**

Inhalation : Remarks: None known.

Skin contact : Remarks: Causes skin irritation.

Eye contact : Remarks: Contact with the eyes may be very painful but does
not cause damage.

Ingestion : Remarks: None known.

SECTION 12. ECOLOGICAL INFORMATION**Ecotoxicity****Product:**

Toxicity to fish : LC50 (Oncorhynchus mykiss (rainbow trout)): 5.2 mg/l
Exposure time: 96 h

Toxicity to daphnia and other : LC50 (Daphnia magna (Water flea)): 5.8 mg/l
aquatic invertebrates Exposure time: 48 h

Toxicity to algae : EC50 (Selenastrum capricornutum (green algae)): 8.2 mg/l
Exposure time: 96 h

Components:**Tributyl phosphate:**

Toxicity to fish : LC50 (Oncorhynchus mykiss (rainbow trout)): 4.2 mg/l
Exposure time: 96 h

Toxicity to daphnia and other : EC50 (Daphnia magna (Water flea)): 1.8 mg/l

Skydrol® LD4 Fire Resistant Hydraulic Fluid

Version 2.2 Revision Date: 08/09/2016 SDS Number: 150000093409 Date of last issue: 06/02/2015
 Date of first issue: 10/24/2013
 SDSUS / PRD / 0001

aquatic invertebrates	Exposure time: 48 h
Toxicity to algae	: EC50 (Desmodesmus subspicatus (Scenedesmus subspicatus)): 1.1 mg/l Exposure time: 72 h
Toxicity to fish (Chronic toxicity)	: NOEC (Oncorhynchus mykiss (rainbow trout)): 0.82 mg/l Exposure time: 95 d 1.7 mg/l
Toxicity to daphnia and other aquatic invertebrates (Chronic toxicity)	: NOEC (Daphnia magna (Water flea)): 1.3 mg/l Exposure time: 21 d
Dibutylphenylphosphate:	
Toxicity to fish	: LL50 (Cyprinus carpio (Carp)): 1.8 mg/l Exposure time: 96 h
Toxicity to daphnia and other aquatic invertebrates	: EC50 (Daphnia magna (Water flea)): 1.4 mg/l Exposure time: 48 h
Toxicity to algae	: EL50 (Selenastrum capricornutum (green algae)): 9.6 mg/l Exposure time: 72 h Method: EL50 method of the water accommodated fraction (W.A.F.) NOELR (Selenastrum capricornutum (green algae)): 3.5 mg/l Exposure time: 72 h Method: EL50 method of the water accommodated fraction (W.A.F.)
Toxicity to fish (Chronic toxicity)	: NOEC (Oncorhynchus mykiss (rainbow trout)): > 0.11 mg/l Exposure time: 60 d
Toxicity to daphnia and other aquatic invertebrates (Chronic toxicity)	: NOEC (Daphnia magna (Water flea)): 0.106 mg/l Exposure time: 21 d
butylated hydroxytoluene:	
Toxicity to fish	: LC50 (Fish): 0.199 mg/l Exposure time: 96 h
Toxicity to daphnia and other aquatic invertebrates	: EC50 (Daphnia (water flea)): 0.48 mg/l Exposure time: 48 h
Toxicity to algae	: EC50 (Chlorella pyrenoidosa (aglae)): 0.758 mg/l Exposure time: 96 h

Persistence and degradability**Product:**

Biochemical Oxygen Demand (BOD) : Remarks: not determined

Skydrol® LD4 Fire Resistant Hydraulic Fluid

Version 2.2 Revision Date: 08/09/2016 SDS Number: 150000093409 Date of last issue: 06/02/2015
Date of first issue: 10/24/2013
SDSUS / PRD / 0001

Chemical Oxygen Demand (COD) : Remarks: not determined

Components:**Tributyl phosphate:**

Biodegradability : Result: Readily biodegradable

Dibutylphenylphosphate:

Biodegradability : Method: Ready Biodegradability: Manometric Respirometry Test

Remarks: Readily biodegradable

Method: Ready Biodegradability: Modified MITI Test (I)

Remarks: Not readily biodegradable.

7-Oxabicyclo[4.1.0]heptane-3-carboxylic acid, 2-ethylhexyl ester:

Biodegradability : Concentration: 100 mg/l
Method: Ready Biodegradability: Modified MITI Test (I)
Remarks: Readily biodegradable

Bioaccumulative potential**Components:****Tributyl phosphate:**

Bioaccumulation : Species: Cyprinus carpio (Carp)
Bioconcentration factor (BCF): 20
Exposure time: 56 d
Method: OECD Test Guideline 305

Bioconcentration factor (BCF): 35

Exposure time: 38 d

Partition coefficient: n-octanol/water : Pow: 10,100

Dibutylphenylphosphate:

Bioaccumulation : Species: Cyprinus carpio (Carp)
Bioconcentration factor (BCF): 35
Method: OECD Test Guideline 305

Mobility in soil

No data available

Other adverse effects**Product:**

Ozone-Depletion Potential :

Regulation: 40 CFR Protection of Environment; Part 82 Protection of Stratospheric Ozone - CAA Section 602 Class I Substances

Skydrol® LD4 Fire Resistant Hydraulic Fluid

Version Revision Date: SDS Number: Date of last issue: 06/02/2015
2.2 08/09/2016 15000093409 Date of first issue: 10/24/2013
SDSUS / PRD / 0001

Remarks: This product neither contains, nor was manufactured with a Class I or Class II ODS as defined by the U.S. Clean Air Act Section 602 (40 CFR 82, Subpt. A, App.A + B).

SECTION 13. DISPOSAL CONSIDERATIONS**Disposal methods**

Waste from residues : This product meets the criteria for a synthetic used oil under the U.S. EPA Standards for the Management of Used Oil (40 CFR 279). Those standards govern recycling and disposal in lieu of 40 CFR 260 -272 of the Federal hazardous waste program in states that have adopted these used oil regulations. Consult your attorney or appropriate regulatory official to be sure these standards have been adopted in your state. Recycle or burn in accordance with the applicable standards. Dispose of in accordance with local regulations.

SECTION 14. TRANSPORT INFORMATION**International Regulation****IATA-DGR**

Not regulated as a dangerous good

IMDG-Code

Not regulated as a dangerous good

Transport in bulk according to Annex II of MARPOL 73/78 and the IBC Code

Not applicable for product as supplied.

National Regulations**49 CFR**

Not regulated as a dangerous good

SECTION 15. REGULATORY INFORMATION**EPCRA - Emergency Planning and Community Right-to-Know Act****SARA 311/312 Hazards**

: Acute Health Hazard
Chronic Health Hazard

SARA 302

: No chemicals in this material are subject to the reporting requirements of SARA Title III, Section 302.

SARA 313

: This material does not contain any chemical components with known CAS numbers that exceed the threshold (De Minimis) reporting levels established by SARA Title III, Section 313.

Clean Air Act

Skydrol® LD4 Fire Resistant Hydraulic Fluid

Version Revision Date: SDS Number: Date of last issue: 06/02/2015
2.2 08/09/2016 150000093409 Date of first issue: 10/24/2013
SDSUS / PRD / 0001

This product neither contains, nor was manufactured with a Class I or Class II ODS as defined by the U.S. Clean Air Act Section 602 (40 CFR 82, Subpt. A, App.A + B).

This product does not contain any hazardous air pollutants (HAP), as defined by the U.S. Clean Air Act Section 112 (40 CFR 61).

This product does not contain any chemicals listed under the U.S. Clean Air Act Section 112(r) for Accidental Release Prevention (40 CFR 68.130, Subpart F).

This product does not contain any chemicals listed under the U.S. Clean Air Act Section 111 SOCOMI Intermediate or Final VOC's (40 CFR 60.489).

Clean Water Act

This product does not contain any Hazardous Substances listed under the U.S. CleanWater Act, Section 311, Table 116.4A.

This product does not contain any Hazardous Chemicals listed under the U.S. CleanWater Act, Section 311, Table 117.3.

This product does not contain any toxic pollutants listed under the U.S. Clean Water Act Section 307

The components of this product are reported in the following inventories:

DSL : All components of this product are on the Canadian DSL

AICS : On the inventory, or in compliance with the inventory

ENCS : On the inventory, or in compliance with the inventory

KECI : Not listed

PICCS : Not listed

IECSC : On the inventory, or in compliance with the inventory

TSCA : On TSCA Inventory

TSCA list

No substances are subject to a Significant New Use Rule.

No substances are subject to TSCA 12(b) export notification requirements.

SECTION 16. OTHER INFORMATION**Full text of other abbreviations**

AICS - Australian Inventory of Chemical Substances; ASTM - American Society for the Testing of Materials; bw - Body weight; CERCLA - Comprehensive Environmental Response, Compensation, and Liability Act; CMR - Carcinogen, Mutagen or Reproductive Toxicant; DIN - Standard of the German Institute for Standardisation; DOT - Department of Transportation; DSL - Domestic Substances List (Canada); ECx - Concentration associated with x% response; EHS - Extremely Hazardous Substance; ELx - Loading rate associated with x% response; EmS - Emergency Schedule; ENCS - Existing and New Chemical Substances (Japan); ErCx - Concentration associated with x% growth rate response; ERG - Emergency Response Guide; GHS - Globally Harmonized System; GLP - Good Laboratory Practice; HMIS - Hazardous Materials Identification System; IARC - International Agency for Research on Cancer; IATA - International Air Transport

Skydrol® LD4 Fire Resistant Hydraulic Fluid

Version 2.2 Revision Date: 08/09/2016 SDS Number: 150000093409 Date of last issue: 06/02/2015
 Date of first issue: 10/24/2013
 SDSUS / PRD / 0001

Association; IBC - International Code for the Construction and Equipment of Ships carrying Dangerous Chemicals in Bulk; IC50 - Half maximal inhibitory concentration; ICAO - International Civil Aviation Organization; IECSC - Inventory of Existing Chemical Substances in China; IMDG - International Maritime Dangerous Goods; IMO - International Maritime Organization; ISHL - Industrial Safety and Health Law (Japan); ISO - International Organisation for Standardization; KECI - Korea Existing Chemicals Inventory; LC50 - Lethal Concentration to 50 % of a test population; LD50 - Lethal Dose to 50% of a test population (Median Lethal Dose); MARPOL - International Convention for the Prevention of Pollution from Ships; MSHA - Mine Safety and Health Administration; n.o.s. - Not Otherwise Specified; NFPA - National Fire Protection Association; NO(A)EC - No Observed (Adverse) Effect Concentration; NO(A)EL - No Observed (Adverse) Effect Level; NOELR - No Observable Effect Loading Rate; NTP - National Toxicology Program; NZIoC - New Zealand Inventory of Chemicals; OECD - Organization for Economic Co-operation and Development; OPPTS - Office of Chemical Safety and Pollution Prevention; PBT - Persistent, Bioaccumulative and Toxic substance; PICCS - Philippines Inventory of Chemicals and Chemical Substances; (Q)SAR - (Quantitative) Structure Activity Relationship; RCRA - Resource Conservation and Recovery Act; REACH - Regulation (EC) No 1907/2006 of the European Parliament and of the Council concerning the Registration, Evaluation, Authorisation and Restriction of Chemicals; RQ - Reportable Quantity; SADT - Self-Accelerating Decomposition Temperature; SARA - Superfund Amendments and Reauthorization Act; SDS - Safety Data Sheet; TCSI - Taiwan Chemical Substance Inventory; TSCA - Toxic Substances Control Act (United States); UN - United Nations; UNRTDG - United Nations Recommendations on the Transport of Dangerous Goods; vPvB - Very Persistent and Very Bioaccumulative

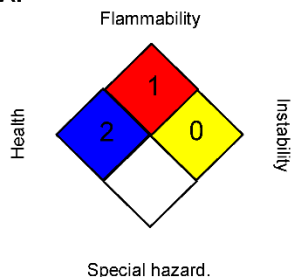
Further information**NFPA:****HMIS III:**

HEALTH	2*
FLAMMABILITY	1
PHYSICAL HAZARD	0

0 = not significant, 1 = Slight,
 2 = Moderate, 3 = High
 4 = Extreme, * = Chronic

Sources of key data used to compile the Safety Data Sheet : www.EastmanAviationSolutions.com
 Revision Date : 08/09/2016

The information provided in this Safety Data Sheet is correct to the best of our knowledge, information and belief at the date of its publication. The information given is designed only as a guidance for safe handling, use, processing, storage, transportation, disposal and release and is not to be considered a warranty or quality specification. The information relates only to the specific material designated and may not be valid for such material used in combination with any other materials or in any process, unless specified in the text.

Skydrol® LD4 Fire Resistant Hydraulic Fluid

Version	Revision Date:	SDS Number:	Date of last issue: 06/02/2015
2.2	08/09/2016	150000093409	Date of first issue: 10/24/2013

SDSUS / PRD / 0001

US / EN



APPENDIX IX

5751

**Safety Data Sheet
HyJet Hydraulic Fluid**

Product Name: HYJET V
 Revision Date: 18 May 2017
 Page 2 of 12

or doctor/physician if you feel unwell. P305 + P351 + P338: IF IN EYES: Rinse cautiously with water for several minutes. Remove contact lenses, if present and easy to do. Continue rinsing. P308 + P313: IF exposed or concerned: Get medical advice/ attention. P314: Get medical advice/attention if you feel unwell. P330: Rinse mouth. P337 + P313: If eye irritation persists: Get medical advice/attention.P405: Store locked up.P501: Dispose of contents and container in accordance with local regulations.

Contains: PHENOL, ISOPROPYLATED, PHOSPHATE (3:1) [TRIPHENYL PHOSPHATE > 5%]; TRIBUTYL PHOSPHATE

Other hazard information:

HAZARD NOT OTHERWISE CLASSIFIED (HNOC): None as defined under 29 CFR 1910.1200.

PHYSICAL / CHEMICAL HAZARDS

No significant hazards.

HEALTH HAZARDS

High-pressure injection under skin may cause serious damage. When heated, the vapors/fumes given off may cause respiratory tract irritation. Frequent or prolonged contact may defat and dry the skin, leading to discomfort and dermatitis.

ENVIRONMENTAL HAZARDS

Expected to be harmful to aquatic organisms. May cause long-term adverse effects in the aquatic environment.

NFPA Hazard ID:	Health: 2	Flammability: 1	Reactivity: 0
HMIS Hazard ID:	Health: 2*	Flammability: 1	Reactivity: 0

NOTE: This material should not be used for any other purpose than the intended use in Section 1 without expert advice. Health studies have shown that chemical exposure may cause potential human health risks which may vary from person to person.

SECTION 3	COMPOSITION / INFORMATION ON INGREDIENTS
------------------	-------------------------------------------------

This material is defined as a mixture.

Hazardous Substance(s) or Complex Substance(s) required for disclosure

Name	CAS#	Concentration*	GHS Hazard Codes
2,6-DI-TERT-BUTYL-P-CRESOL	128-37-0	0.1 - < 1%	H400(M factor 1), H410(M factor 1)
7-OXABICYCLO-(4.1.0)-HEPTANE 3-CARBOXYLIC ACID, 2-ETHYLHEXYL ESTER	62256-00-2	5 - 7%	H315, H319(2A), H317
PHENOL, ISOPROPYLATED, PHOSPHATE (3:1) [TRIPHENYL PHOSPHATE > 5%]	68937-41-7	10 - < 20%	H361(D), H361(F), H373, H401, H411
TRIBUTYL PHOSPHATE	126-73-8	70 - < 80%	H302, H315, H402, H412

* All concentrations are percent by weight unless material is a gas. Gas concentrations are in percent by volume.

As per paragraph (i) of 29 CFR 1910.1200, formulation is considered a trade secret and specific chemical identity and

SAFETY DATA SHEET

SECTION 1 PRODUCT AND COMPANY IDENTIFICATION**PRODUCT**

Product Name: HYJET V
Product Description: Synthetic Base Stocks and Additives
Product Code: 201050303020, 430330-00, 97Y953
Intended Use: Aviation hydraulic fluid

COMPANY IDENTIFICATION

Supplier: EXXON MOBIL CORPORATION
22777 Springwoods Village Parkway
Spring, TX 77253 USA

**24 Hour Health Emergency
Transportation Emergency Phone
Product Technical Information
MSDS Internet Address**

609-737-4411
800-424-9300 or 703-527-3887 CHEMTREC
800-662-4525
www.exxon.com, www.mobil.com

SECTION 2 HAZARDS IDENTIFICATION

This material is hazardous according to regulatory guidelines (see (M)SDS Section 15).

CLASSIFICATION:

Acute oral toxicant: Category 4. Eye irritation: Category 2A. Reproductive toxicant (developmental): Category 2. Reproductive toxicant (fertility): Category 2. Specific target organ toxicant (repeated exposure): Category 2.

LABEL:**Pictogram:**

Signal Word: Warning

Hazard Statements:

H302: Harmful if swallowed. H319: Causes serious eye irritation. H361: Suspected of damaging fertility or the unborn child. H373: May cause damage to organs through prolonged or repeated exposure. Liver, Adrenal

Precautionary Statements:

P201: Obtain special instructions before use. P202: Do not handle until all safety precautions have been read and understood. P260: Do not breathe mist / vapours. P264: Wash skin thoroughly after handling. P270: Do not eat, drink or smoke when using this product. P273: Avoid release to the environment. P280: Wear protective gloves/protective clothing/eye protection/face protection. P301 + P312: IF SWALLOWED: Call a POISON CENTER

exact percentage (concentration) of composition may have been withheld. Specific chemical identity and exact percentage composition will be provided to health professionals, employees, or designated representatives in accordance with applicable provisions of paragraph (i).

SECTION 4 FIRST AID MEASURES

INHALATION

Remove from further exposure. For those providing assistance, avoid exposure to yourself or others. Use adequate respiratory protection. If respiratory irritation, dizziness, nausea, or unconsciousness occurs, seek immediate medical assistance. If breathing has stopped, assist ventilation with a mechanical device or use mouth-to-mouth resuscitation.

SKIN CONTACT

Wash contact areas with soap and water. Remove contaminated clothing. Launder contaminated clothing before reuse. If product is injected into or under the skin, or into any part of the body, regardless of the appearance of the wound or its size, the individual should be evaluated immediately by a physician as a surgical emergency. Even though initial symptoms from high pressure injection may be minimal or absent, early surgical treatment within the first few hours may significantly reduce the ultimate extent of injury.

EYE CONTACT

Flush thoroughly with water for at least 15 minutes. Get medical assistance.

INGESTION

Seek immediate medical attention. Do not induce vomiting.

SECTION 5 FIRE FIGHTING MEASURES

EXTINGUISHING MEDIA

Appropriate Extinguishing Media: Use water fog, foam, dry chemical or carbon dioxide (CO₂) to extinguish flames.

Inappropriate Extinguishing Media: Straight Streams of Water

FIRE FIGHTING

Fire Fighting Instructions: Evacuate area. Prevent runoff from fire control or dilution from entering streams, sewers, or drinking water supply. Firefighters should use standard protective equipment and in enclosed spaces, self-contained breathing apparatus (SCBA). Use water spray to cool fire exposed surfaces and to protect personnel.

Unusual Fire Hazards: May generate irritating and harmful gases/vapors/fumes when burning. Pressurized mists may form a flammable mixture. Hazardous material. Firefighters should consider protective equipment indicated in Section 8.

Hazardous Combustion Products: Aldehydes, Incomplete combustion products, Nitrogen oxides, Phosphorus oxides, Smoke, Fume, Sulfur oxides

FLAMMABILITY PROPERTIES

Flash Point [Method]: 160°C (320°F) - 175°C (347°F) [ASTM D-92]

Product Name: HYJET V
Revision Date: 18 May 2017
Page 4 of 12

Flammable Limits (Approximate volume % in air): LEL: N/D UEL: N/D
Autoignition Temperature: 400°C (752°F)

SECTION 6 ACCIDENTAL RELEASE MEASURES

NOTIFICATION PROCEDURES

In the event of a spill or accidental release, notify relevant authorities in accordance with all applicable regulations. US regulations require reporting releases of this material to the environment which exceed the applicable reportable quantity or oil spills which could reach any waterway including intermittent dry creeks. The National Response Center can be reached at (800)424-8802.

PROTECTIVE MEASURES

Avoid contact with spilled material. Warn or evacuate occupants in surrounding and downwind areas if required due to toxicity or flammability of the material. See Section 5 for fire fighting information. See the Hazard Identification Section for Significant Hazards. See Section 4 for First Aid Advice. See Section 8 for advice on the minimum requirements for personal protective equipment. Additional protective measures may be necessary, depending on the specific circumstances and/or the expert judgment of the emergency responders.

SPILL MANAGEMENT

Land Spill: Eliminate all ignition sources (no smoking, flares, sparks or flames in immediate area). Stop leak if you can do it without risk. Prevent entry into waterways, sewer, basements or confined areas. Ventilate the area. Recover by pumping or with suitable absorbent. Absorb or cover with dry earth, sand or other non-combustible material and transfer to containers.

Water Spill: Stop leak if you can do it without risk. Confine the spill immediately with booms. Warn other shipping. Remove from the surface by skimming or with suitable absorbents. Seek the advice of a specialist before using dispersants.

Water spill and land spill recommendations are based on the most likely spill scenario for this material; however, geographic conditions, wind, temperature, (and in the case of a water spill) wave and current direction and speed may greatly influence the appropriate action to be taken. For this reason, local experts should be consulted. Note: Local regulations may prescribe or limit action to be taken.

ENVIRONMENTAL PRECAUTIONS

Large Spills: Dike far ahead of liquid spill for later recovery and disposal. Prevent entry into waterways, sewers, basements or confined areas.

SECTION 7 HANDLING AND STORAGE

HANDLING

Avoid all personal contact. Avoid vapors from heated materials to prevent exposure to potentially toxic/irritating fumes. Prevent small spills and leakage to avoid slip hazard.

Static Accumulator: This material is not a static accumulator.

STORAGE

Do not store in open or unlabelled containers.

SECTION 8	EXPOSURE CONTROLS / PERSONAL PROTECTION
------------------	------------------------------------------------

EXPOSURE LIMIT VALUES

Exposure limits/standards (Note: Exposure limits are not additive)

Substance Name	Form	Limit / Standard			NOTE	Source
2,6-DI-TERT-BUTYL-P-CRESOL	Inhalable fraction and vapor	TWA	2 mg/m3		N/A	ACGIH
TRIBUTYL PHOSPHATE		TWA	5 mg/m3		N/A	OSHA Z1
TRIBUTYL PHOSPHATE	Inhalable fraction and vapor	TWA	5 mg/m3		N/A	ACGIH

NOTE: Limits/standards shown for guidance only. Follow applicable regulations.

No biological limits allocated.

ENGINEERING CONTROLS

The level of protection and types of controls necessary will vary depending upon potential exposure conditions. Control measures to consider:
 Adequate ventilation should be provided so that exposure limits are not exceeded.

PERSONAL PROTECTION

Personal protective equipment selections vary based on potential exposure conditions such as applications, handling practices, concentration and ventilation. Information on the selection of protective equipment for use with this material, as provided below, is based upon intended, normal usage.

Respiratory Protection: If engineering controls do not maintain airborne contaminant concentrations at a level which is adequate to protect worker health, an approved respirator may be appropriate. Respirator selection, use, and maintenance must be in accordance with regulatory requirements, if applicable. Types of respirators to be considered for this material include:
 No protection is ordinarily required under normal conditions of use and with adequate ventilation.

For high airborne concentrations, use an approved supplied-air respirator, operated in positive pressure mode. Supplied air respirators with an escape bottle may be appropriate when oxygen levels are inadequate, gas/vapor warning properties are poor, or if air purifying filter capacity/rating may be exceeded.

Hand Protection: Any specific glove information provided is based on published literature and glove manufacturer data. Glove suitability and breakthrough time will differ depending on the specific use conditions. Contact the glove manufacturer for specific advice on glove selection and breakthrough times for your use conditions. Inspect and replace worn or damaged gloves. The types of gloves to be considered for this material include:
 Chemical resistant gloves are recommended.

Product Name: HYJET V
Revision Date: 18 May 2017
Page 6 of 12

Eye Protection: Chemical goggles are recommended.

Skin and Body Protection: Any specific clothing information provided is based on published literature or manufacturer data. The types of clothing to be considered for this material include:
Chemical/oil resistant clothing is recommended.

Specific Hygiene Measures: Always observe good personal hygiene measures, such as washing after handling the material and before eating, drinking, and/or smoking. Routinely wash work clothing and protective equipment to remove contaminants. Discard contaminated clothing and footwear that cannot be cleaned. Practice good housekeeping.

ENVIRONMENTAL CONTROLS

Comply with applicable environmental regulations limiting discharge to air, water and soil. Protect the environment by applying appropriate control measures to prevent or limit emissions.

SECTION 9 PHYSICAL AND CHEMICAL PROPERTIES

Note: Physical and chemical properties are provided for safety, health and environmental considerations only and may not fully represent product specifications. Contact the Supplier for additional information.

GENERAL INFORMATION

Physical State: Liquid
Form: Clear
Color: Violet
Odor: Sweet
Odor Threshold: N/D

IMPORTANT HEALTH, SAFETY, AND ENVIRONMENTAL INFORMATION

Relative Density (at 15 °C): 0.993
Flammability (Solid, Gas): N/A
Flash Point [Method]: 160°C (320°F) - 175°C (347°F) [ASTM D-92]
Flammable Limits (Approximate volume % in air): LEL: N/D UEL: N/D
Autoignition Temperature: 400°C (752°F)
Boiling Point / Range: 288°C (550°F)
Decomposition Temperature: N/D
Vapor Density (Air = 1): N/D
Vapor Pressure: 0.067 kPa (0.5 mm Hg) at 20 °C
Evaporation Rate (n-butyl acetate = 1): N/D
pH: N/D
Log Pow (n-Octanol/Water Partition Coefficient): N/D
Solubility in Water: Negligible
Viscosity: 10.1 cSt (10.1 mm²/sec) at 40 °C | 3.5 cSt (3.5 mm²/sec) at 100°C
Oxidizing Properties: See Hazards Identification Section.

OTHER INFORMATION

Freezing Point: N/D
Melting Point: N/A
Pour Point: -62°C (-80°F)

SECTION 10	STABILITY AND REACTIVITY
-------------------	---------------------------------

REACTIVITY: See sub-sections below.

STABILITY: Material is stable under normal conditions.

CONDITIONS TO AVOID: Excessive heat.

MATERIALS TO AVOID: Strong oxidizers

HAZARDOUS DECOMPOSITION PRODUCTS: Material does not decompose at ambient temperatures.

POSSIBILITY OF HAZARDOUS REACTIONS: Hazardous polymerization will not occur.

SECTION 11	TOXICOLOGICAL INFORMATION
-------------------	----------------------------------

INFORMATION ON TOXICOLOGICAL EFFECTS

Hazard Class	Conclusion / Remarks
Inhalation	
Acute Toxicity: No end point data for material.	Minimally Toxic. Based on assessment of the components.
Irritation: No end point data for material.	Elevated temperatures or mechanical action may form vapors, mist, or fumes which may be irritating to the eyes, nose, throat, or lungs.
Ingestion	
Acute Toxicity (Rat): LD50 1.348 g/kg	Slightly toxic. Based on test data for the material. Test(s) equivalent or similar to OECD Guideline 401
Skin	
Acute Toxicity: No end point data for material.	Minimally Toxic. Based on assessment of the components.
Skin Corrosion/Irritation (Rabbit): Data available.	Negligible irritation to skin at ambient temperatures. Based on test data for the material. Test(s) equivalent or similar to OECD Guideline 404
Eye	
Serious Eye Damage/Irritation: No end point data for material.	Irritating and will injure eye tissue. Based on assessment of the components.
Sensitization	
Respiratory Sensitization: No end point data for material.	Not expected to be a respiratory sensitizer.
Skin Sensitization: No end point data for material.	Not expected to be a skin sensitizer. Based on assessment of the components.
Aspiration: Data available.	Not expected to be an aspiration hazard. Based on physico-chemical properties of the material.
Germ Cell Mutagenicity: No end point data for material.	Not expected to be a germ cell mutagen. Based on assessment of the components.
Carcinogenicity: No end point data for material.	Not expected to cause cancer. Based on assessment of the components.
Reproductive Toxicity: No end point data for material.	Caused damage to fertility in laboratory animals, but the relevance to humans is uncertain. Caused damage to the fetus in laboratory animals, but the relevance to humans is uncertain. Based on assessment of the components.
Lactation: No end point data for material.	Not expected to cause harm to breast-fed children.
Specific Target Organ Toxicity (STOT)	

Product Name: HYJET V
 Revision Date: 18 May 2017
 Page 8 of 12

Single Exposure: No end point data for material.	Not expected to cause organ damage from a single exposure.
Repeated Exposure: No end point data for material.	Concentrated, prolonged or deliberate exposure may cause organ damage. Based on assessment of the components.

TOXICITY FOR SUBSTANCES

NAME	ACUTE TOXICITY
2,6-DI-TERT-BUTYL-P-CRESOL	Oral Lethality: LD50 0.89 g/kg (Rat)
TRIBUTYL PHOSPHATE	Oral Lethality: LD50 1552 ml/kg (Rat)

OTHER INFORMATION

For the product itself:

Target Organs Repeated Exposure: Liver, Adrenal

Component concentrations in this formulation would not be expected to cause skin sensitization, based on tests of the components, this formulation, or similar formulations.

Contains:

Tributyl phosphate (TBP): Studies in rats have shown an increased incidence of urinary bladder tumors following long-term feeding of TBP in the diet. No bladder tumors were observed in similar studies in mice. The relevance of these findings for humans is uncertain.

Isopropylphenyl phosphate (iPP). Reproductive / developmental toxicity screening studies in rats of products containing high concentrations of iPP adversely affected male and female reproductive performance with significant reductions in fertility and conception indices. Number of rat pups born and live litter size were decreased in groups exposed to the iPP-containing products, while pup mortality was increased.

The following ingredients are cited on the lists below: None.

--REGULATORY LISTS SEARCHED--

1 = NTP CARC
 2 = NTP SUS

3 = IARC 1
 4 = IARC 2A

5 = IARC 2B
 6 = OSHA CARC

SECTION 12	ECOLOGICAL INFORMATION
-------------------	-------------------------------

The information given is based on data available for the material, the components of the material, and similar materials.

ECOTOXICITY

Material -- Expected to be harmful to aquatic organisms. May cause long-term adverse effects in the aquatic environment.

SECTION 13	DISPOSAL CONSIDERATIONS
-------------------	--------------------------------

Disposal recommendations based on material as supplied. Disposal must be in accordance with current applicable laws and regulations, and material characteristics at time of disposal.

DISPOSAL RECOMMENDATIONS

Protect the environment. Dispose of used oil at designated sites. Minimize skin contact. Do not mix used oils with solvents, brake fluids or coolants. Product is suitable for burning in an enclosed, controlled burner for fuel value or disposal by supervised incineration.

REGULATORY DISPOSAL INFORMATION

RCRA Information: The unused product, in our opinion, is not specifically listed by the EPA as a hazardous waste (40 CFR, Part 261D), nor is it formulated to contain materials which are listed as hazardous wastes. It does not exhibit the hazardous characteristics of ignitability, corrosivity or reactivity and is not formulated with contaminants as determined by the Toxicity Characteristic Leaching Procedure (TCLP). However, used product may be regulated.

Empty Container Warning Empty Container Warning (where applicable): Empty containers may contain residue and can be dangerous. Do not attempt to refill or clean containers without proper instructions. Empty drums should be completely drained and safely stored until appropriately reconditioned or disposed. Empty containers should be taken for recycling, recovery, or disposal through suitably qualified or licensed contractor and in accordance with governmental regulations. **DO NOT PRESSURISE, CUT, WELD, BRAZE, SOLDER, DRILL, GRIND, OR EXPOSE SUCH CONTAINERS TO HEAT, FLAME, SPARKS, STATIC ELECTRICITY, OR OTHER SOURCES OF IGNITION. THEY MAY EXPLODE AND CAUSE INJURY OR DEATH.**

SECTION 14	TRANSPORT INFORMATION
-------------------	------------------------------

LAND (DOT): Not Regulated for Land Transport

Footnote: This material is not regulated under 49 CFR if in a container of 119 gallon capacity or less, except when transported by vessel.

LAND (TDG): Not Regulated for Land Transport

Footnote: Regulated under TDG as UN 3082, Environmentally Hazardous Substance, liquid, Class 9, Marine Pollutant, only when transported by ship.

SEA (IMDG): Not Regulated for Sea Transport according to IMDG-Code

Marine Pollutant: No

AIR (IATA): Not Regulated for Air Transport

Product Name: HYJET V
 Revision Date: 18 May 2017
 Page 10 of 12

SECTION 15	REGULATORY INFORMATION
------------	------------------------

OSHA HAZARD COMMUNICATION STANDARD: This material is considered hazardous in accordance with OSHA HazCom 2012, 29 CFR 1910.1200.

Listed or exempt from listing/notification on the following chemical inventories: DSL, IECSC, TSCA
Special Cases:

Inventory	Status
AICS	Restrictions Apply
KECI	Restrictions Apply

SARA 302: No chemicals in this material are subject to the reporting requirements of SARA Title III, Section 302

SARA (311/312) REPORTABLE HAZARD CATEGORIES: Immediate Health. Delayed Health.

SARA (313) TOXIC RELEASE INVENTORY: This material contains no chemicals subject to the supplier notification requirements of the SARA 313 Toxic Release Program.

The following ingredients are cited on the lists below:

Chemical Name	CAS Number	List Citations
CYCLOHEXANESULFONIC ACID, DECAFLUORO(PENTAFLUOROTHYL)-, POTASSIUM SALT	67584-42-3	6
CYCLOHEXANESULFONIC ACID, DECAFLUORO(TRIFLUOROMETHYL)-, POTASSIUM SALT	68156-07-0	6
CYCLOHEXANESULFONIC ACID, NONAFLUOROBIS(TRIFLUOROMETHYL)-, POTASSIUM SALT.	68156-01-4	6
CYCLOHEXANESULFONIC ACID, UNDECAFLUORO-, POTASSIUM SALT	3107-18-4	6
TRIBUTYL PHOSPHATE	126-73-8	1, 4, 13, 16, 18

--REGULATORY LISTS SEARCHED--

- | | | | |
|---------------|--------------|-------------------|-------------|
| 1 = ACGIH ALL | 6 = TSCA 5a2 | 11 = CA P65 REPRO | 16 = MN RTK |
| 2 = ACGIH A1 | 7 = TSCA 5e | 12 = CA RTK | 17 = NJ RTK |
| 3 = ACGIH A2 | 8 = TSCA 6 | 13 = IL RTK | 18 = PA RTK |
| 4 = OSHA Z | 9 = TSCA 12b | 14 = LA RTK | 19 = RI RTK |

Product Name: HYJET V
Revision Date: 18 May 2017
Page 11 of 12

5 = TSCA 4 10 = CA P65 CARC 15 = MI 293

Code key: CARC=Carcinogen; REPRO=Reproductive

SECTION 16	OTHER INFORMATION
-------------------	--------------------------

N/D = Not determined, N/A = Not applicable

KEY TO THE H-CODES CONTAINED IN SECTION 3 OF THIS DOCUMENT (for information only):

H302: Harmful if swallowed; Acute Tox Oral, Cat 4
H315: Causes skin irritation; Skin Corr/Irritation, Cat 2
H317: May cause allergic skin reaction; Skin Sensitization, Cat 1
H319(2A): Causes serious eye irritation; Serious Eye Damage/Irr, Cat 2A
H361: Suspected of damaging fertility or the unborn child.; Repro Tox, Cat 2
H361(D): Suspected of damaging the unborn child; Repro Tox, Cat 2 (Develop)
H361(F): Suspected of damaging fertility; Repro Tox, Cat 2 (Fertility)
H373: May cause damage to organs through prolonged or repeated exposure; Target Organ, Repeated, Cat 2
H400: Very toxic to aquatic life; Acute Env Tox, Cat 1
H401: Toxic to aquatic life; Acute Env Tox, Cat 2
H402: Harmful to aquatic life; Acute Env Tox, Cat 3
H410: Very toxic to aquatic life with long lasting effects; Chronic Env Tox, Cat 1
H411: Toxic to aquatic life with long lasting effects; Chronic Env Tox, Cat 2
H412: Harmful to aquatic life with long lasting effects; Chronic Env Tox, Cat 3

THIS SAFETY DATA SHEET CONTAINS THE FOLLOWING REVISIONS:

Composition: Component Table information was modified.
GHS Target Organ List information was added.
GHS Target Organ List information was deleted.
Section 01: Company Contact Methods information was modified.
Section 01: Company Mailing Address information was modified.
Section 04: First Aid Notes information was deleted.
Section 05: Hazardous Combustion Products information was modified.
Section 06: Accidental Release - Spill Management - Land information was modified.
Section 09: Flash Point C(F) information was modified.
Section 11: Chronic Tox - Component information was modified.
Section 11: Other Health Effects information was added.
Section 11: Other Health Effects information was deleted.
Section 11: Target Organ Toxicity Repeat - Organ Systems information was modified.
Section 14: Marine Pollutant information was modified.

The information and recommendations contained herein are, to the best of ExxonMobil's knowledge and belief, accurate and reliable as of the date issued. You can contact ExxonMobil to insure that this document is the most current available from ExxonMobil. The information and recommendations are offered for the user's consideration and examination. It is the user's responsibility to satisfy itself that the product is suitable for the intended use. If buyer repackages this product, it is the user's responsibility to insure proper health, safety and other necessary information is included with and/or on the container. Appropriate warnings and safe-handling procedures should be provided to handlers and users. Alteration of this document is strictly prohibited. Except to the extent required by law, re-publication or retransmission of this document, in whole or in part, is not permitted. The term, "ExxonMobil" is used for convenience, and may include any one or more of ExxonMobil Chemical Company, Exxon Mobil Corporation, or any affiliates in which they directly or indirectly hold any interest.



Product Name: HYJET V
Revision Date: 18 May 2017
Page 12 of 12

Internal Use Only

MHC: 1, 0, 0, 2, 0, 1

PPEC: D

DGN: 7010394XUS (1008302)

Copyright 2002 Exxon Mobil Corporation, All rights reserved



APPENDIX X

Instrument Certification Notice



Instrument Certification Notice

The gauge Certificates of Calibration supplied for the gauge(s) on this unit contain the calibration data for the actual instrument calibrated, along with the calibration date of the **STANDARD** used to perform the calibration check.

The due date for re-calibration of the instrument should be based upon the date the instrument was placed in service in your facility. Re-calibration should be done on a periodic basis as dictated by the end user's quality system or other overriding requirements.

Note that Tronair, Inc. does not supply certificates of calibration on flow meters or pyrometers unless requested at the time of placed order. These instruments are considered reference indicators only and are not critical to the test(s) being performed on the aircraft.